

RADIO'S GREATEST MAGAZINE

RADIO NEWS

REG. U.S. PAT. OFF.

JULY

25 CENTS

ARTHUR H. LYNCH Editorial Director



In This Issue

"THE VELVETONE—29"

An All-Electric Five-Tube Tuner—
Single Control—Exceptional Gain and Selectivity

BY JAMES MILLEN AND GLENN BROWNING

TELEVISION

RADIOVISION

IT'S SO EASY TO BUILD FROM THIS BOOK

New!

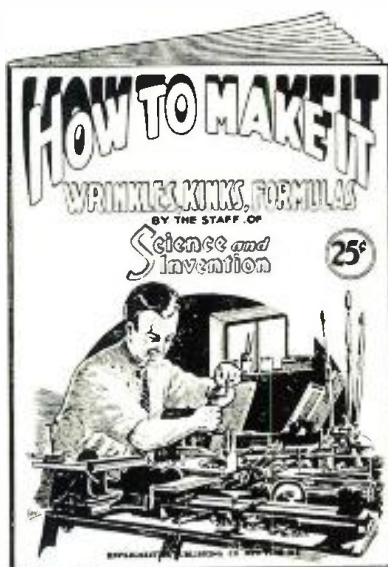

Fully Illustrated
only

25c
Per Copy

At All Newsstands
or Write Direct

Hundreds of Things You Can Do!

“THAR’S GOLD IN THEM THAR HILLS, PARDNER.” How often have you read that expression? How often have you longed for a machine that would tell you the exact spot at which to dig in order to locate the gold about which the prospector speaks? How often have you been told that a pot of gold has been buried on an estate somewhere and which would make the individual fabulously wealthy if he could but discover where that pot of gold is to be found? There are mechanisms which will do that. One of them is an electrical treasure locator built on the principle of an induction balance. The construction of such a treasure locator is described in detail in this “How To Make It Book.” In it you will find many other treasures. Full details for the grinding of a mirror and the making of a telescope, building a model tug-boat, a deaf-phone that is of real benefit, the construction of a small lathe, an enlarging machine, a telegraphone (a machine which electrically records the voice on a steel wire), and myriads of wrinkles, recipes and instructional articles too numerous to mention, and written so you can understand it by the staff of SCIENCE AND INVENTION, publishers of this magazine.

“Thar’s gold in them thar hills, Pardner,” and there is a wealth of information in this well-illustrated book.

This big book of mechanical formulas—
fully illustrated — large magazine size.

**EXPERIMENTER
PUBLICATIONS, INC.**

381 FOURTH AVENUE NEW YORK

MAIL TO-DAY

EXPERIMENTER PUBLICATIONS, Inc.,
381 Fourth Avenue, New York, N. Y.

RN-JY9

Gentlemen:

Please send me a copy of your book, “How To Make It.” Enclosed please find 25 cents.

Name

Address

City..... State.....



5 Easy Ways to Make \$3.00 an hour in Your Spare Time in RADIO

Each of these plans, developed by the Radio Training Association of America, is a big money-maker. Set owners everywhere want to get rid of static, to have their sets operate from the electric light socket, the tone improved, and the volume increased, and transformed into single-dial controls. Phonograph owners want their machines electrified and radiofied. If you learn to render these services, you can easily make \$3.00 an hour for your spare time, to say nothing of the money you can make installing, servicing, repairing, building radio sets, and selling supplies.

Over \$600,000,000 is being spent yearly for sets, supplies, service. You can get your share of this business and, at the same time, fit yourself for the big-pay opportunities in Radio by joining the Association.

Join the Radio Training Association of America

A membership in the Association offers you the easiest way into Radio. It will enable you to earn \$3.00 an hour upwards in your spare time—train you to install, repair and build all kinds of sets—start you in business without capital or finance an invention—train you for the \$3,000 to \$10,000 big-pay radio positions—help secure a better position at bigger pay for you.

A membership need not cost you a cent! The Association will give you a comprehensive, practical, and theoretical training and the benefit of its Employment Service. You earn while you learn. Our cooperative plan will make it possible for you to establish a radio store. You have the privilege of buying radio supplies at wholesale from the very first.

Earned \$500.00 Spare Time
 Frank J. Deutsch, Penn.: "I have made over \$500 out of Radio in my spare time."

Radio Engineer in One Year
 Claude De Grave, Canada: "I knew nothing about Radio when I joined a year ago. I am now a member of a very exclusive organization of Radio Engineers, and my income is 225% greater than it was."

Doubles Income in 6 Months
 W. E. Thon, Chicago: "Six months after I enrolled I secured the managership of large Radio Store and doubled my income."

ACT NOW — If You Wish the No-Cost Membership Plan

To a limited number of ambitious men, we will give Special Memberships that may not—need not—cost you a cent. To secure one, write today. We will send you details and also our Radio Handbook filled with dollars-and-cents radio ideas. It will open your eyes to the money-making possibilities of Radio.

Radio Training Association of America
 4513 Ravenswood Ave., Dept. RN-7, Chicago, Ill.

Radio Training Association of America
 Dept. RN-7, 4513 Ravenswood Ave., Chicago, Ill.

Gentlemen: Please send me by return mail full details of your Special Membership Plan, and also copy of your Radio Handbook.

Name.....

Address.....

City..... State.....

Radio News

Volume XI

JULY, 1929

No. 1

W. THOMSON LEES
Managing Editor

ARTHUR H. LYNCH, Editorial Director
JOHN B. BRENNAN, JR.
Technical Editor

C. WALTER PALMER
Associate Editor

CONTENTS OF THIS ISSUE

Frontispiece: An Important Radio Link in the Antarctic.....	6
Current Comment.....	9
Notes, news flashes and interpretations of the month's developments.	
Squads—Attention!.....	13
By ARTHUR STRINGER—How radio has enlisted in Chicago's war on organized crime.	
The Velvetone 29.....	14
By JAMES MILLEN and GLENN BROWNING—A new five-tube tuner of exceptional gain.	
The Problems of Aircraft Radio.....	18
By ZEH BOUCK—What American radio engineers are doing toward making flying safe.	
The Story of Our Cover for This Month.....	22
A stirring Antarctic rescue as told in newspaper headlines.	
Our Fifty-Dollar Prize Winning Short-Wave Set.....	24
By E. T. SOMERSET—The first winner in our short-wave set prize contest.	
"Hello, Little America; New York Calling".....	26
By FRED A. MEINHOLTZ—How the <i>Times</i> maintains contact with Commander Byrd.	
Reporting From the Air.....	29
How to Build the Band Isolator Receiver—Part II.....	30
By S. GORDON TAYLOR—Constructional details of this interesting receiver, whose circuit was discussed in last month's issue.	
A Portable Short-Wave Transmitter and Multiwave Receiver.....	33
By LIEUT. WILLIAM A. WENSTROM—A truly portable transmitter and receiver.	
Twenty-four Hours With a Short-Wave Receiver.....	40
By CURTIS GLEN.	
How Radio Aids Aviation Abroad.....	42
By W. THOMSON LEES—How the Air Ministries in England, Germany, and France function.	
A Tube and Set Tester for a Lean Purse.....	46
By M. K. BARBER—A constructional article that will be a boon to servicemen and experimenters.	
Opportunities in the Radio and Audio Arts.....	49
By CARL DREHER—The ever-enlarging field in radio and allied arts, for the young engineer.	
The RE-29—Part II.....	53
By R. E. LACAULT—Constructional details of the receiver, together with the power-pack, and data on the automatic volume control.	
Experiments on the Ultra-High Frequencies.....	57
By THOMAS A. MARSHALL—The results of a nine months' test on extreme short-wave bands, and details of the push-pull tuner circuit employed in the receiver developed by the author.	
The New Silver Radio Receiver.....	60
By MCMURDO SILVER—A new receiver, using the a.c. screen grid tube.	
An Amplifier-Power Supply for the "Beginner's Three" Receiver.....	63
By C. WALTER PALMER—Providing volume and electric operation for this popular receiver.	
The Radio Forum.....	66
A meeting place for the serviceman, experimenter and short-wave enthusiast.	
The Trade Broadcasts.....	71
New equipment and manufacturing trends.	

(Advertisers' Index will be found on page 92)

RADIO NEWS is published monthly, on the tenth day of each month preceding that of date. Entered as second-class matter, July 12, 1924, at the postoffice, Jamaica, N. Y., under the act of March 3, 1879. Additional entry at San Francisco, Calif. Copyright 1929 by Experimenter Publications, Inc.; title registered U. S. Patent Office. Subscription price \$2.50 a year; \$3.00 in Canada and foreign countries.

Single copies, 25 cents each. The contents of RADIO NEWS are indexed in the Industrial Arts Index. Communications and manuscripts should be addressed to the Editor, Radio News, 381 Fourth Ave., New York, N. Y.; subscriptions and orders for magazines and other publications to the Circulation Department, Experimenter Publications, Inc., 381 Fourth Ave., New York, N. Y.

Published by Experimenter Publications, Inc.

B. A. MACKINNON, President
Member: Audit Bureau of Circulations

H. K. FLY, Vice-President and Treasurer
Radio Magazine Publishers' Association

Editorial and General Offices 381 Fourth Avenue, New York City

Published Monthly by the Experimenter Publications, Inc., at 184-10 Jamaica Ave., Jamaica, N. Y.
Entered as Second-Class Matter at Jamaica, N. Y., under Act of March 3, 1879.
Executive and Editorial Offices, 381 Fourth Ave., New York, N. Y.

Who else wants *Quick Success* in **RADIO**?

SPONSORED BY



**Pick the job you
want and fill it
in nine months**

Here, at last, a method that brings
success in radio . . . in amazingly
fast time! Sponsored by the Radio
Corporation of America. No pre-
vious radio knowledge necessary.
Complete practical course—with
marvelous home-laboratory outfit
prepares you step-by-step for
success in all branches of radio
. . . servicing . . . selling . . . ship
and shore broadcasting . . . tele-
vision . . . radio operating. Satis-
faction guaranteed or money
refunded!

FREE—This fascinating book on
Radio's glorious opportunities.
Act now. Mail the coupon.

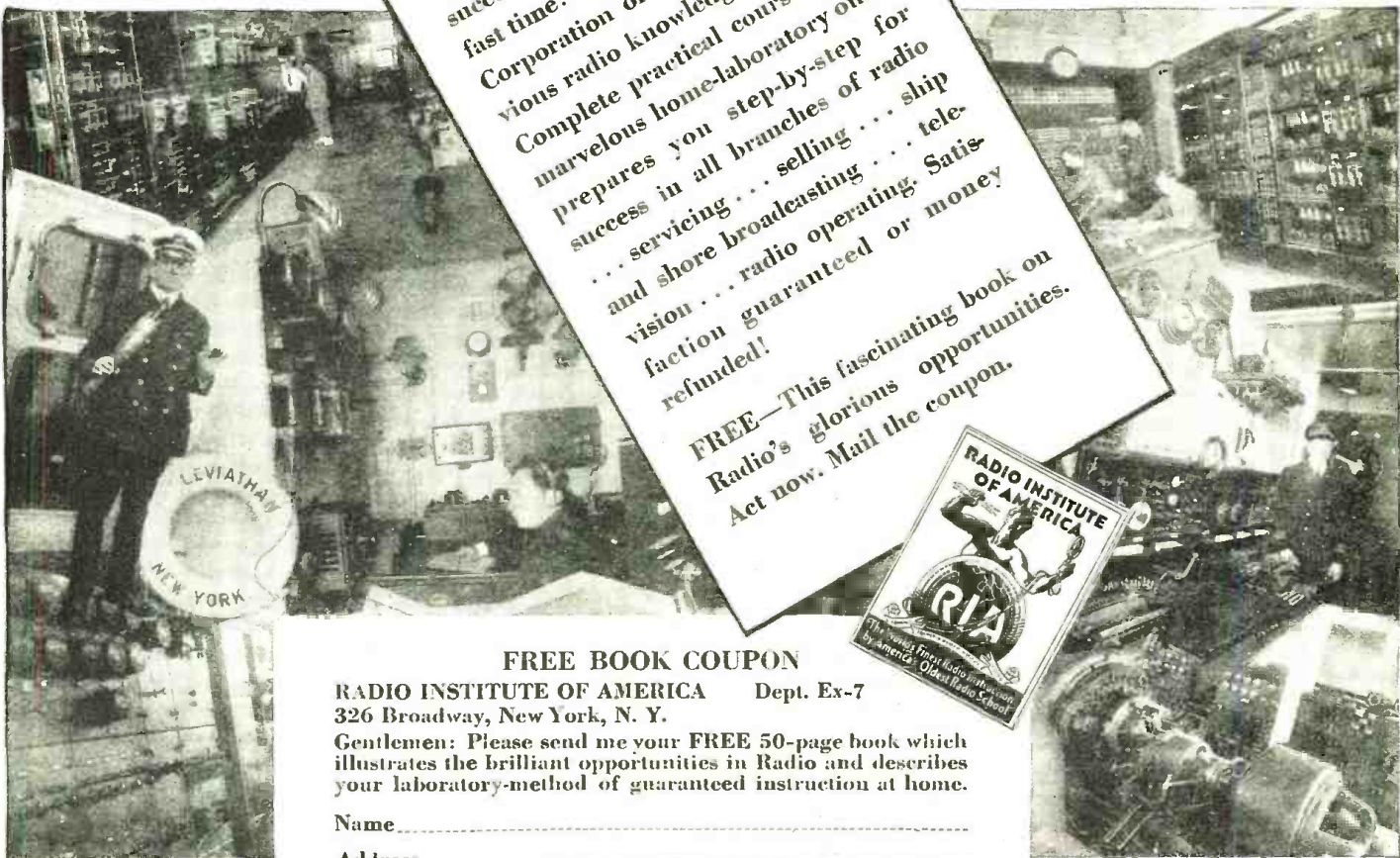

FREE BOOK COUPON

RADIO INSTITUTE OF AMERICA Dept. Ex-7
326 Broadway, New York, N. Y.

Gentlemen: Please send me your **FREE** 50-page book which
illustrates the brilliant opportunities in Radio and describes
your laboratory-method of guaranteed instruction at home.

Name _____

Address _____



RADIO INSTITUTE OF AMERICA ★ ★ ★

McMURDO SILVER



Announces

Silver

And now, at last, comes Silver-Marshall's entry into the complete RCA—licensed radio receiver field with SILVER RADIO—the most sensational development since a.c. tubes revolutionized radio.

1929 is a Screen-Grid year. Its pace will be set by the new type radio that is SILVER RADIO—so original and so advanced technically as to be *utterly different from any other manufactured receiver*. For SILVER RADIO comes from a designer, a laboratory, and a factory that have *mastered* Screen-Grid technique—and *proved* it by chalking up unbroken records with the Sargent-Rayment Seven, and the famous Screen-Grid Sixes.

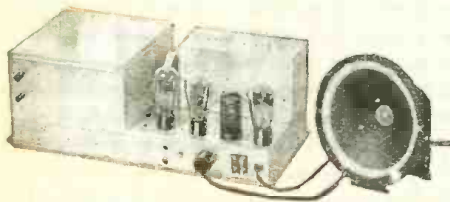

The SILVER RADIO chassis and speaker above is made complete in the new home of Silver-Marshall pictured below—the third largest exclusive radio plant in the Chicago area. The eight-tube Model 30 chassis (as furnished in Model 60 Lowboy and Model 95 Highboy) contains the fully shielded, non-oscillating Screen-Grid r. f. amplifier, with hand selector, Screen-Grid power detector, push-pull power amplifier and A. B. C. and speaker power supply. It is a marvel of mechanical and electrical engineering. In all comparative tests so far, no other radio has been found which can even equal its performance.

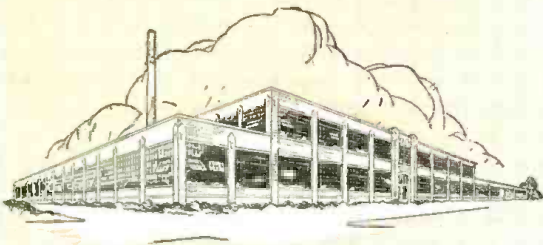

SILVER RADIO is nothing if not *new*. It is first to *eliminate all antenna installation*. It is first to use *three 224 a. c. Screen-Grid tubes* as r. f. amplifiers with *band-selector tuning*, followed by a *fourth* Screen-Grid tube in the newest type of power detector circuit. SILVER RADIO is first to use a pair of 245 power tubes in push-pull; first to use a *matched-impedance* dynamic speaker. And SILVER RADIO is first also with a startling development—the *Over-tone Switch*, which brings out all the beauty of ordinarily-lost high notes as does no other radio—yet cuts them out at will to reduce static in bad weather. And prices—SILVER RADIO is first with prices so low that they actually make you gasp, even though they are made possible by tremendous production.

SILVER-MARSHALL, Incorporated

SM

"Silver on Radio is like

Radio

Just as a.c. tubes changed the "fashion" in radios from battery to light socket in 1927—just as surely will SILVER RADIO revolutionize public demand in 1929. For you know that the amazing new features of SILVER RADIO spell *revolution* in radio results—for distance, for selectivity, tone, convenience, and low cost.

Appreciation is due, and is in full measure given, to the many friends whose use and recommendation of S-M products has pushed SILVER-MARSHALL up into the position of dominating leadership in the parts field, now to launch forth, from one of the largest radio plants in America, the self-contained SILVER RADIO receivers. And Silver-Marshall has kept faith with these friends—SILVER RADIO is just the outstandingly superior product that they have always expected from the S-M laboratories.

SILVER RADIO will be distributed through leading jobbers to franchised dealers in exclusively allotted territories—backed by an unprecedentedly large newspaper advertising allowance per set, to "break" in the early summer. Dealer demonstrations are being arranged now, and franchise applications are being received.

6415 W. 65th St., Chicago, U. S. A.

Sterling on Silver



Model 60 Lowboy (above) and Model 95 Highboy (below) are finely built of striped walnut, in Sheraton period, finished in high gloss lacquer. Both contain the same 8-tube a. c. Screen-Grid SILVER RADIO chassis, matched dynamic speaker, and screen antenna. They are absolutely complete, less only 4-24, 1-27, 2-45 and 1-80 tubes (flat price of tubes, \$29.50). Model 60 Lowboy is priced at \$160; Model 95 Highboy at \$195 (slightly higher west of the Rockies). Both models operate on 100 to 130 volt, 50 to 60 cycle a. c. (25 cycle model special)



SILVER-MARSHALL, Inc.
6415 West 65th Street, Chicago, Ill., U. S. A.

Send me the dope, and tell me where I can see and hear it—I'm interested.

Name.....
Address.....
City..... State.....

An Important Radio Link in the Antarctic

THE 2,000 METER, 6KW RADIO TELEGRAPH STATION LOCATED AT GRIJTVIKEN, SOUTH GEORGIA, IN THE ANTARCTIC OCEAN, JUST NORTH OF THE ANTARCTIC CIRCLE. THIS STATION, BEARING ITS STURDY MASTS AMID THE BLEAK SURROUNDINGS, MAINTAINS A COMMUNICATION SERVICE WITH SOUTH AMERICAN COUNTRIES

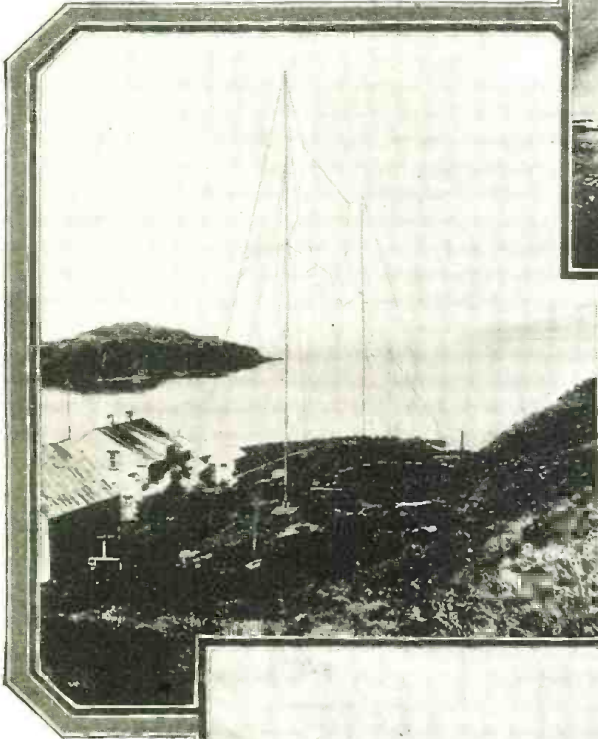
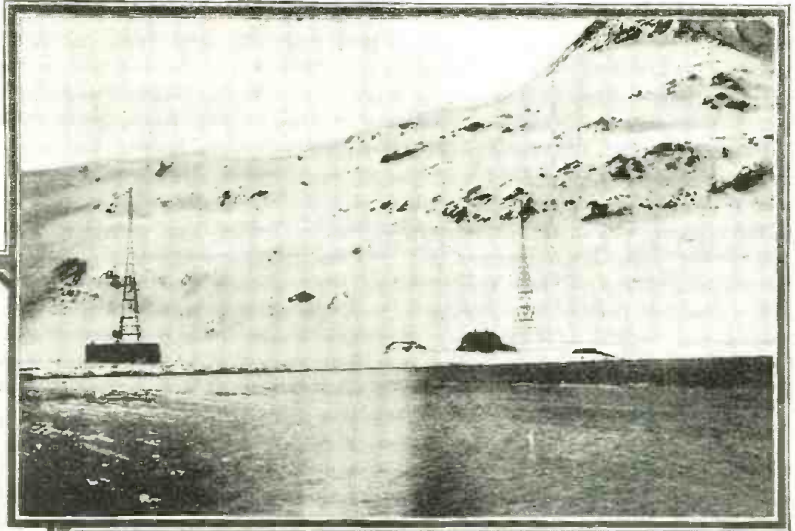

AT PRINCE OLAF HARBOR, SOUTH GEORGIA, A LESS PRETENTIOUS BUT JUST AS IMPORTANT STATION AS THE ONE AT GRIJTVIKEN IS IN OPERATION, MAINTAINING CONSTANT CONTACT WITH COMMANDER BYRD AND HIS COMRADES IN THE ANTARCTIC. THE STATION, WHOSE ANTENNA INSTALLATION IS SHOWN AT THE LEFT, IS EQUIPPED FOR RADIO TELEPHONE COMMUNICATION AND ALSO KEEPS IN TOUCH WITH THE MANY WHALING VESSELS WHICH STILL OPERATE IN THAT PART OF THE GLOBE



PRINCE OLAF HARBOR, SOUTH GEORGIA, THE HAVEN OF THE WHALING VESSELS. A ONCE PROMINENT INDUSTRY STILL CARRIES ON IN THIS OUT-OF-THE-WAY PLACE. SOME IDEA OF THE BARREN AND BLEAK COUNTRY CAN BE OBTAINED FROM THE PICTURE ABOVE

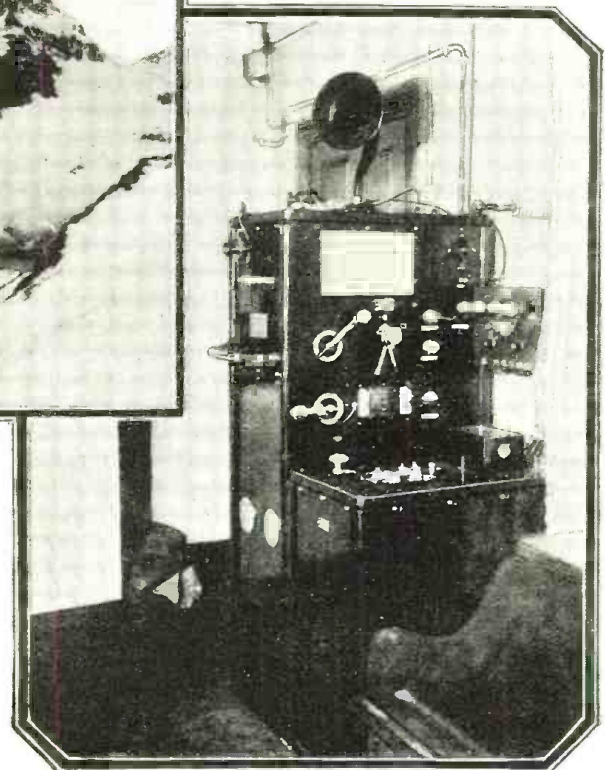

THE 400-600 METER TRANSMITTER OF THE 1/2 KW RADIO TELEPHONE STATION AT PRINCE OLAF HARBOR, SOUTH GEORGIA (RIGHT)

WILBUR C. WHITEHEAD'S *new* "Picture Method" teaches **BRIDGE**

Drawing for partners.

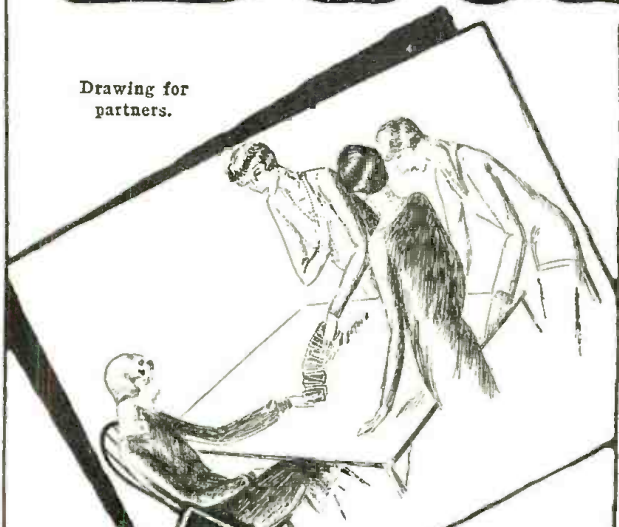

An example of the way in which each hand is illustrated.

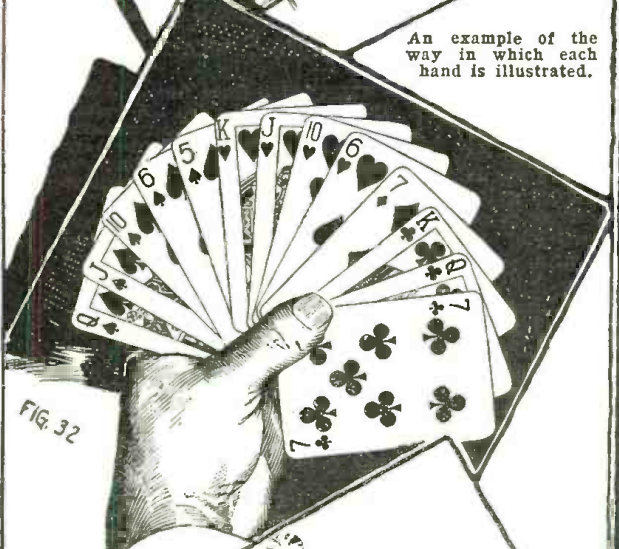

FIG. 32

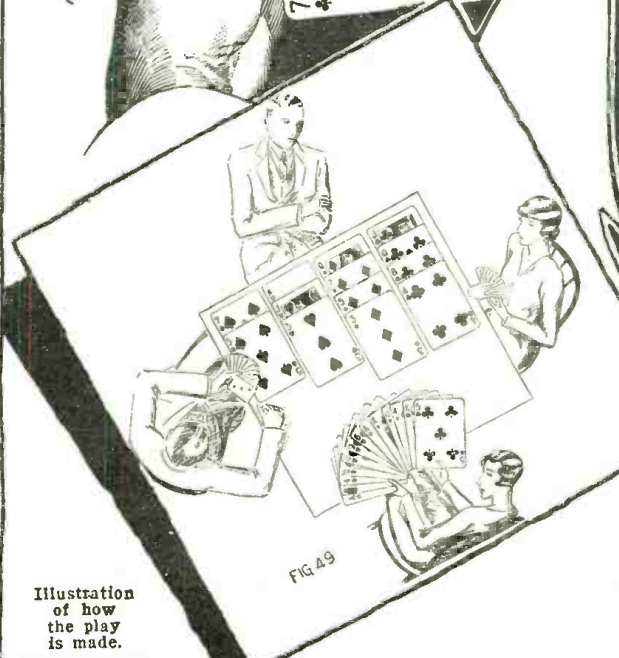

FIG. 49

Illustration of how the play is made.

easily and quickly.

Printed in **2 COLORS** Red and Black Cards

WILBUR C. WHITEHEAD, the world renowned bridge expert, has written this interesting instruction course for you. BRIDGE by Whitehead is unique in that it teaches the entire game of bridge by a new and original form of illustration known as Whitehead's "PICTURE METHOD." Every hand is illustrated, each card in its proper color, red or black as the case may be. Thus the beginner, or even the most seasoned player, has an actual illustration of the manner in which the play is made always before him.

Whitehead, whose reputation as the foremost authority, national or international, on the game of bridge, is one whose advice cannot be taken lightly; he knows the game as few others know it. In this book he passes on to his readers, in an easily understandable fashion, his picture method—which made him a recognized success.

This most practical volume is bound with a beautifully printed colored cover, and contains 100 pages, size 9" x 12". Remember each progressive point is completely illustrated.

Get Your Copy of
BRIDGE by Whitehead

(The regular price of which is 50 cents) with a 4 month subscription to

RADIO NEWS

both for only **\$1.00**

MAIL THIS COUPON NOW

EXPERIMENTER PUBLICATIONS, INC.
381 Fourth Avenue
New York, N. Y.

RN-JY9

Enter my subscription for 4 months of RADIO NEWS and send me a copy of BRIDGE by Whitehead, for which I enclose \$1.00 (coin, stamps or check) in full payment.

Name.....

Address.....

City..... State.....

SM

S-M Reduced Prices Mark a New Era Of Confidence

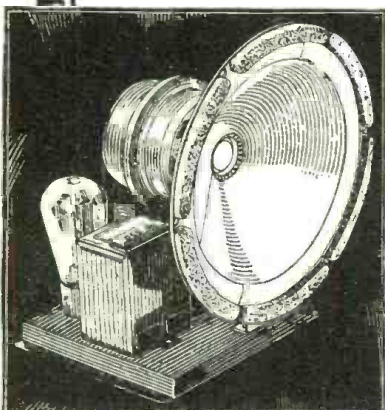

YES— Something Happened in Speakers When the S-M Appeared

The new S-M speaker is fast becoming as famous an audio product as Silver-Marshall's immensely popular Clough-system audio transformers. So accurately designed is this new speaker unit that it eliminates all objectionable hum as well as "drummy" tones, and brings out both low and high pitches with a fidelity hitherto unobtainable. Two types: 851 for 110-volt d.c., \$29.10 net. 850, for 50-60 cycle 105-120 volt a.c. (using 1—'80 tube), \$35.10 net.

FOR a long time Silver-Marshall has felt that the "list price" method of pricing prevalent in the radio parts business was not conducive to public confidence, and that it should be discarded in favor of an honest and straightforward policy. The situation today is that fully 95% of all radio parts sold go to professional setbuilders, service men or experimenters with commercial connections, who buy at a fictitious "list" price less a discount, usually about 40%. As this discount is available thru, actually, millions of mail order and jobber catalogues, to any and every buyer, the list price is indeed fictitious, and serves no purpose except to destroy confidence.

For this reason Silver-Marshall, as America's largest parts manufacturer, believes that the time has come to "clean house" in the industry—alone if necessary. Therefore, effective April 15th, all S-M list prices were reduced about 40%, so that the new list prices are now about the net prices available to all. No "dollars and cents" change is made—an outworn fiction only is discarded. Henceforth, the professional setbuilder and service man will never be embarrassed when, after selling a set, he is confronted by his customer with a net price catalog. There will be only one selling price on S-M apparatus—the new "net-list," at which consumers, setbuilders, and professional setbuilders can all buy.

This change is intended to, and will, protect service stations and professionals, who, buying parts at the same prices their customers obtain, have their profits insured by a fair and generous differential (to cover their labor) between the cost of parts to their customers and the cost of factory wired sets.

S-M believes that this frank and open policy will insure confidence among those it is designed to protect and help—the consumer, the setbuilder, the service station and jobbers, for it protects the professional from cut-price competition, consequently makes selling easier, and inspires confidence, not mistrust, in his customer.

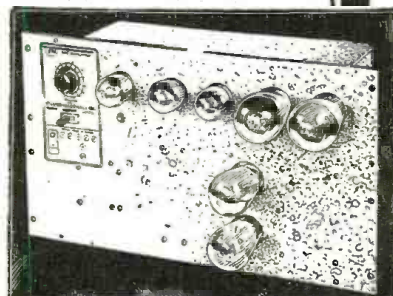

S-M Power Amplifiers With Clough-System Tone

Operating entirely from the a.c. light socket, and using the famous S-M Clough-system audio transformers, these amplifiers give the very finest reproduction at auditorium-volume obtainable on the market today.

S-M 690, to reach 2000 or more people, has three stages (last two push-pull); supplies 6 to 12 or more dynamic speakers. Fading control on panel, and three-point switch for record—microphone—radio input selection. Uses 1—'27, 2—'26, 2—'50, and 2—'81 tubes. Price, less tubes, \$147, net.

S-M 679, to reach 1000 or more people, has two stages; supplies 2 to 4 or more dynamic speakers. Binding posts for microphone—radio—record pickup input. Uses 1—'26, 1—'50, 2—'81 tubes. Price less tubes, \$81, net.

S-M "PA" type amplifiers are available for all larger experimental installations at surprisingly reduced prices, as shown in our new April 15th catalog.

S-M's monthly publication, *The RADIOBUILDER*, is mighty interesting reading these days. Issue No. 12 (April, 1929) contained a forecast of band selector tuning as it will characterize 1930 receivers; also a timely discussion of the "one-stage" audio trend. If you are not getting the *RADIOBUILDER*, be sure to send the coupon—and send it anyway for the new S-M April catalog, containing new low S-M list prices, which are net.

Authorized S-M Service Stations have made money this season, and still bigger opportunities are opening up for them. Ask us about the Service Station appointment.

SILVER-MARSHALL, Inc.

6405 West 65th St., Chicago, U. S. A.

Silver-Marshall, Inc.
6405 W. 65th St., Chicago, U. S. A.

.... Please send me, free, the new April S-M Catalog; also sample copy of the *RADIOBUILDER*.

For enclosed in stamps, send me the following:

- \$1.00 Next 12 issues of *The Radiobuilder*
- \$1.00 Next 25 issues of *The Radiobuilder*
- S-M DATA SHEETS as follows, at 2c each:
- No. 1. 670B, 670ABC Reservoir Power Units
- No. 2. 685 Public Address Unitpac
- No. 3. 730, 731, 732 "Round-the-World" Short Wave Sets
- No. 4. 223, 225, 226, 256, 251 Audio Transformers
- No. 5. 720 Screen Grid Six Receiver
- No. 6. 740 "Coast-to-Coast" Screen Grid Four
- No. 7. 675ABC High-Voltage Power Supply and 676 Dynamic Speaker Amplifier
- No. 8. Sargent-Rayment Seven
- No. 9. 678PD Phonograph Amplifier
- No. 10. 728AC All-Electric Screen-Grid Six
- No. 12. 669 Power Unit (for 720AC)

Name.....

Address.....

Radio News

Vol. 11

JULY, 1929

No. 1

Current Comment

BACK in the Spring of 1922, we vividly remember going up to the Hotel Pennsylvania, New York, where we had been told that there was some kind of a "radio show."

Following that historic show at the Hotel Pennsylvania, the public "discovered" radio. There followed a hectic scramble for "the latest" circuits, parts and designs. Instead of a total of less than a dozen stations broadcasting programs on a regular schedule, the number rapidly grew into the hundreds. Instead of having to build, or get some kind friend to build, a set that would bring in the programs, the would-be listener found manufacturing plants springing up like mushrooms, eager to supply his wants ready-made. All this, and much more, in the brief space of seven years; and today we take our excellent programs and

our excellent loudspeaker reproduction as a matter of course; and that, to the average citizen, is radio.

But that, today, is only a part—a very small part, in fact—of what radio is, and is doing. As an adjunct to marine operations, radio established itself years ago; but the end of its development even in that field is not yet in sight, as witness the comparatively recent application of compass bearings to locating ships in distress. Nor is the development of radio technique in the field of broadcast entertainment by any means complete. Electrical, mechanical and acoustical engineers are constantly working for improvements and refinements. These, however, are only two small cross-sections of an immense field: the almost limitless field of radio as a whole.

The *New York Telegram* recently car-

ried an editorial which sums up the true situation, and we are glad to reprint it here, in full:

Radio and Infinity

"Eight years ago, when a program of phonograph records was broadcast from Newark and picked up on earphone sets in New York, it appeared that the ultimate in radio had been reached.

"Almost any ingenious youngster could transform a few feet of bell wire and a bit of crystal into a simple set that would pull in the 'Second Connecticut March' or 'The Stars and Stripes Forever.'

BELOW, LEFT TO RIGHT, ARE GENERAL ATTERBURY, MESSRS. WILSON, LEMMON, AND HOYT, MR. C. M. KEYS AND MR. CUTHELL, ON THE OCCASION OF THE DEDICATION OF STATION WRNY UNDER ITS NEW OWNERSHIP

Copyright Wide World

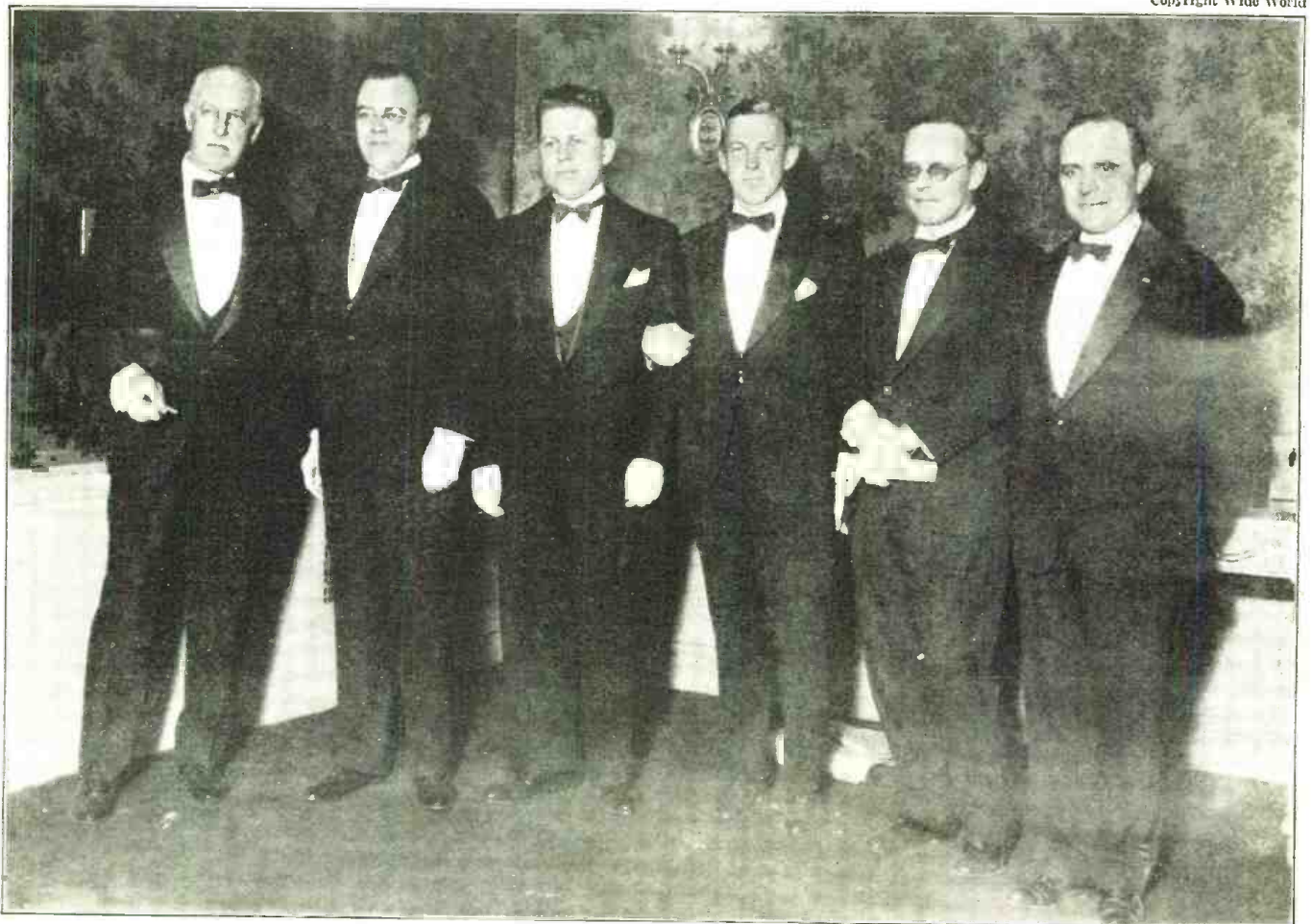

"Now it would seem that there is no ultimate in radio achievement except infinity. Epochal tests by the Canadian National Railway near Toronto indicate the futility of attempting to predict the extent of developments in this field.

"Now we talk casually from moving trains; we send telegrams from them; we even broadcast from them and simultaneously pick up the broadcast on the train.

"A few years ago the man who ventured to predict these things would have been considered a logical candidate for the insane asylum. Years before that he

a good one you pulled. The boys laughed so much we missed part of your talk. Give my best to Harry and love to Betty. Glad to note you are the same old egg. Let you know tomorrow about what the hen thinks about it.

Bill, you old rascal, we sure were glad to get your message. Where in blazes is Trubee? Remember me to him. Berkner has been a wonder. Great asset to expedition. So long, Bill.

One great thing about this place; there are no speeches, thank God.

Hello, Dick. How about a Japanese wrestle as soon as I get back? I am practicing and expect to lick you when I get back. Fell on the stove the other day

battle of Roosevelt Field with us.
DICK BYRD.

In announcing the policy of WRNY under its new ownership, Mr. C. M. Keys, president of Curtiss Aeroplane & Motor Company, said in part:

"The principal thought of myself and my associates in buying the radio station from which I am speaking is based upon the fact that this station owns not only a service for the broadcasting of programs for the amusement and interest of the people in the vicinity of New York, but also a short-wavelength station which can reach and does reach almost any part of the world; and I believe that as time goes on *these two arts, aviation and radio, will go hand in hand, will grow together in size and in usefulness to humanity and will serve one another more directly and more closely than any other two sciences have ever served one another at any time.* (The italics are ours.)

"Personally, I believe that we could not operate, in this country of great distances and of very variable weather, any great transportation system in sufficient safety if we did not have at our command the services of the radio, the backing of the glorious group of radio engineers who serve that art in this country, the generous funds for experimentation and development, and the great capital of these radio interests. . . ."

* * *

Television Emerging from the Laboratory

Television, the present major interest as an expansion of the entertainment phase of radio, would seem to be not very far around the corner. Presented and exploited in a "half-baked" state, before it had outgrown its laboratory swaddling-clothes, this legitimate offspring of radio arose like a rocket and came down like a stick. It is beginning to overcome that handicap, however—

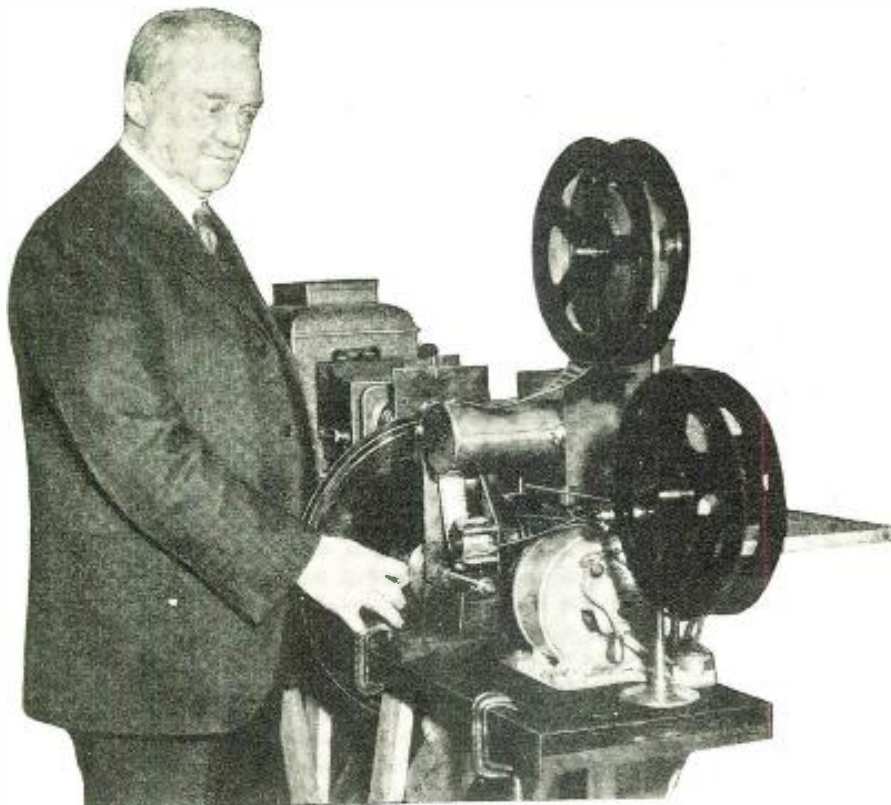

Copyright Underwood & Underwood

ABOVE IS MR. C. FRANCIS JENKINS WITH THE RADIO MOVIE TRANSMITTER WHICH HE HAS DEVELOPED. AT THE RIGHT IS A PHOTOGRAPH RECENTLY RECEIVED OF A NEW GERMAN TELEVISION AND BROADCAST RECEIVER

might have been burned at the stake for witchcraft."

* * * *

An Outstanding Event

An event of outstanding importance to both radio and aviation occurred on the evening of May 8. We refer, of course, to the dedication ceremonies marking the taking over of radio station WRNY, with its short-wave twin, W2XAL, by the Curtiss Aeroplane & Motor Company. A special program was arranged, including a number of personal messages to members of the Byrd expedition in the Antarctic, the entire event being put on the air on both broadcast and short-wave channels.

The dramatic feature of the occasion was an extemporaneous telegraphic reply from Commander Byrd, some 11,000 miles away:

Little America, Antarctica,
May 8, 1929.

Toastmaster: You can't imagine how good it was to hear the voices of so many of my old friends. I envy you the good time you are having. We haven't any of that down here. Jerry, old fellow, that's

wrestling with Strom and now have three stitches in my head.

Say, Casey (Jones), where did you learn to make a speech? There must be something behind it. You were eloquent, old fellow, and I know only one thing that will make you eloquent. No, no submarine for me. Can't get me in one of those dangerous things.

Greetings, Gen. Atterbury. Mighty glad to hear from you. We haven't forgotten the things you did for us. You should see our boy scout now. He weighs two hundred and five pounds.

This occasion you are celebrating is simply great and I wish you every possible success. Aviation is looking up, thank the Lord, and it's about time. Cheerio to every one of you from every one of us. By the gods of war, it was good to hear you. You could appreciate how we felt if you sit six months of night on a godforsaken hunk of ice, though ice is as dry as the desert. Good-night and cheerio to the newspaper boys who fought the

Copyright P. & A. Photo

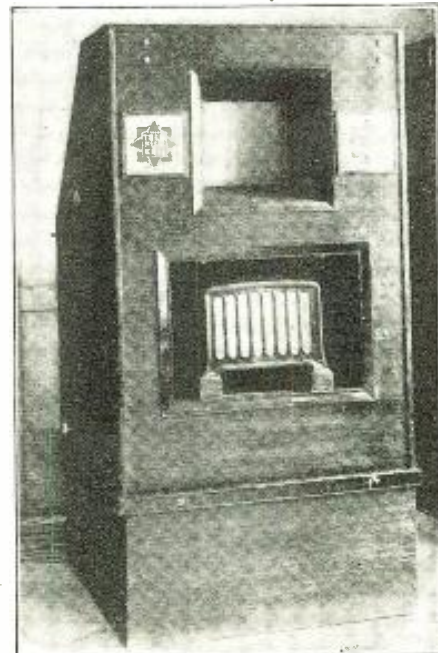

just as so many incubator babies later overcome the handicap of premature birth.

The conservative Radio Corporation of America, through one of its experimental stations, is actually transmitting television on a regular schedule, and there are rumors of an impending R. C. A. television receiver. The Jenkins laboratories have been transmitting for some time, from Washington and from Jersey City, and even go so far as to promise a reasonably-priced home television receiver to be on the market before cold weather sets in. As yet, the size of the reproduced image is disappointingly small, and detail far from satisfactory; but laboratory results show promise of some rather startling improvements in practical transmission in the very near future.

Meanwhile, if we are to take at face value a photograph recently received from Germany, that country is by no means behind us in the development of

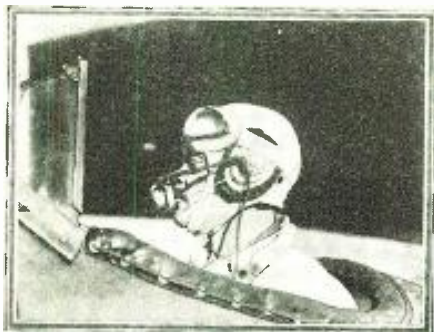

Copyright Underwood & Underwood

MICROPHONE AND RECEIVER HARNESS USED BY PILOTS ON THE BOEING SYSTEM FOR TWO-WAY PHONE COMMUNICATION.

television. The illustration of this most recent German combination of television and voice receiver shows a screen which would imply that the received image is of a size far beyond anything so far considered practical in this country up to the present time. For the present, we shall consider this as being in the nature of a "news flash," subject to later confirmation and possible elaboration.

An application of television principles that would seem to have fascinating possibilities, is the so-called radio television eye, with which C. Francis Jenkins is now undertaking experiments. It involves the use of a television set installed in an airplane, picking up and transmitting what the camera records of action on the ground below the plane. While these experiments are being conducted with emphasis on the military value of such a device, it requires little imagination to predict what it would mean in peacetime, in connection with major spectacles and sports events.

* * * *

In the latter part of April, the *Leviathan* brought to New York a young Frenchman, Rene Lefevre, 24 years old, together with an airplane built by A. Bernard, of France. The young man is one of the two pilots who plan to fly the plane from New York to Paris, this summer, via the Lindbergh trail. Remembering the almost heartsick anxiety of the millions who awaited word of Lindy's safety through so many silent hours, one detail of the contemplated flight is especially interesting.

From the time of the take-off, the *New York Times* has arranged to receive constant, direct messages from the plane, reporting its progress and conditions encountered en route. Unless the broadcasting interests are asleep, or the *Times* proves unduly selfish, a large number of our staid citizenry may experience the thrills of a vicarious flight to Paris this summer.

* * * *

The *Graf Zeppelin*, whose transatlantic visit last year was marred by what seemed to be discourteous bungling in the matter of keeping in radio communication with Lakehurst, is due to have arrived and departed before these words are in print; though, at the present writing, her departure from Germany is still some five days off. Present announced plans, however, call for her return, later in the Summer; to undertake a round-the-world cruise, with Lakehurst as a base.

Most significant of all, the *Graf Zeppelin*

has been equipped with what is said to be the last word in radio communication equipment, and plans to keep in close touch with these shores on her way over; later, also, keeping the world informed of her progress while circling the globe. A recent press dispatch, announcing that the dirigible has been char-

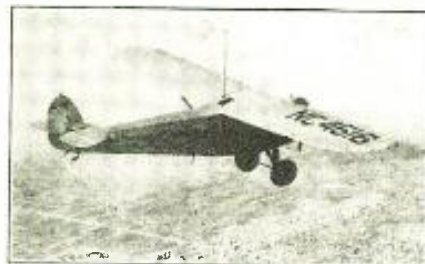

Copyright P. & A.

FAIRCCHILD CABIN MONOPLANE RECENTLY USED BY BELL LABORATORIES IN DEMONSTRATING TWO-WAY COMMUNICATION BETWEEN PLANE AND GROUND WITH A HOOK-UP DIRECT TO THE LAND TELEPHONE LINES

tered by the International Society for the Exploration of the Arctic Regions by Aircraft, for an expedition from Leninograd to either Nome or Fairbanks, in the Spring of 1930, holds promise that we have not long to wait until we may experience, at second-hand, a trip over the polar cap.

* * * *

Two-way telephone communication between airplane and ground is not new, even in the United States, which has lagged far behind Europe in this application of radio. Recently, however, engineers of the Bell Telephone Laboratories demonstrated that they were not to be outdone by their European cousins. Not content with ordinary two-way phone communication, they added the important link of hooking the ground end of the

DR. LEE DE FOREST RECEIVING THE JOHN SCOTT MEDAL FROM THE BOARD OF DIRECTORS OF CITY TRUSTS, PHILADELPHIA.

Copyright Underwood & Underwood

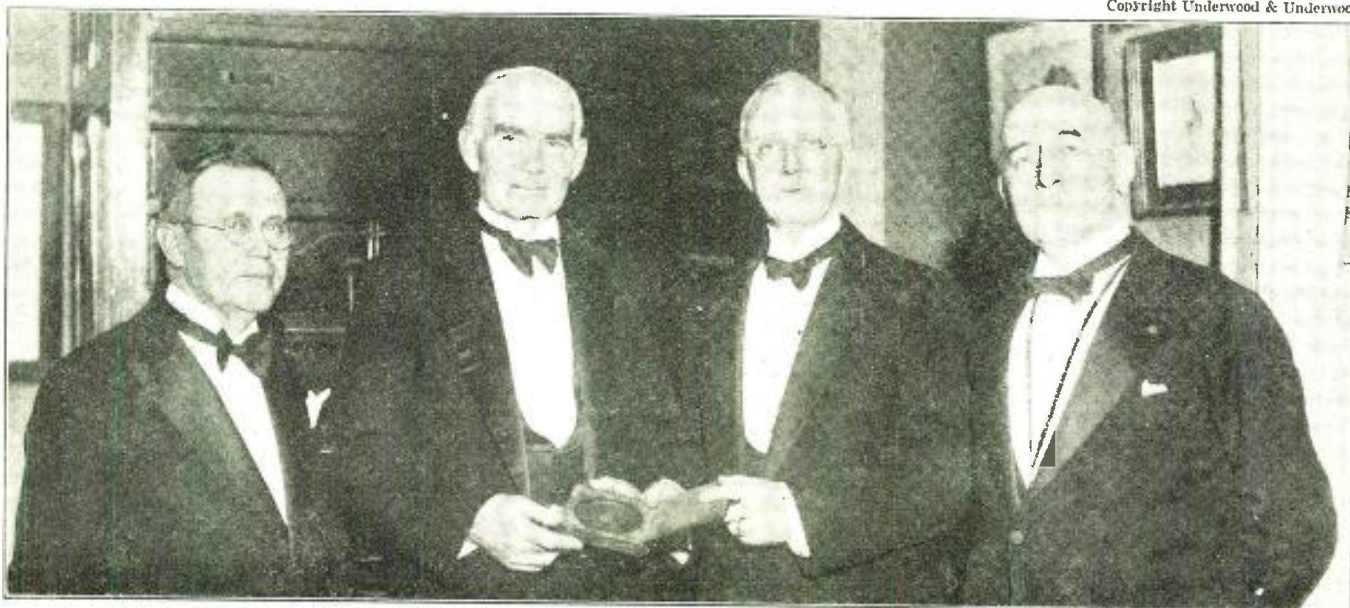

chain to the regular long-distance telephone system; permitting the participating press representatives, in an airplane some thousand feet or more aloft, to call up their respective newspapers.

Companion-piece to that development, was the demonstration of the feasibility of maintaining communication between the established land telephone system and a moving train. This demonstration took place on a train of the Canadian National Railways, on May 5. Not only did it prove the feasibility of telephoning from a speeding train just as comfortably as from the ordinary house phone, but an added touch of novelty resulted when Mr. W. D. Robb, chief of telegraph communication, aboard the train, called up radio station CNRT; the latter putting his voice on the air.

As a result of all this, we shudder to think of what might have happened during the recent national political campaign if these possibilities had been more generally known. Fortunately, a three-year interval of peace lies ahead, before we must again be urged to vote for (or, as is usually the case, against) a Presidential candidate; and by that time the novelty will have worn off. Incidentally—we whisper it—these demonstrations are new only in the sense that they have recently been properly presented to the public. As a matter of fact, engineers of the Bell Telephone Laboratories will tell you that they are "pre-war stuff," brought out of the store-room now, only because of the hitherto impenetrable apathy of aviation



Copyright International Newsreel

MR. BURKHOLDER, CHIEF ENGINEER OF THE CANADIAN NATIONAL TELEGRAPHS (STANDING), AS CONNECTIONS WERE MADE FROM A SPEEDING TRAIN BY RADIO TO THE LAND WIRE SYSTEM

and railroad officials. This apathy finally overcome, however, we may look forward to typically American speed of application.

* * * *

To its devotees, radio has always seemed respectable. We are glad to find increasing recognition of this respectability, on the part of various learned and conservative cultural or scientific bodies.

Among recent evidences, the awarding of the John Scott Medal to Dr. Lee De Forest, by the Board of Directors of City Trusts, Philadelphia, at the recent meeting of the Franklin Institute, was but one of a long chain. The award, which the donor stipulated should be made to men or women "who contributed something of benefit to the human race or who contributed to the progress of science," was made to Dr. De Forest for



Copyright Harris & Ewing

MERLIN H. AYLESWORTH, PRESIDENT OF THE NATIONAL BROADCASTING COMPANY, WHO RECENTLY ANNOUNCED THE PLANS BEING CARRIED OUT FOR EXCHANGE OF TRANS-ATLANTIC PROGRAMS

his invention of the audion or vacuum tube in 1906. It honors a man whose achievements speak for themselves; but it also bestows recognition upon the increasing value, to human life, safety and happiness, of the science and art which we know as radio.

Of even greater interest, perhaps, was the awarding of a gold medal to Milton Cross, well-loved dean of radio announcers, by the American Academy of Arts and Letters. That radio had entered the realms of respectable science, was a commonplace; but that it had penetrated that holy of holies, recognition as a cultural medium, was something distinctly novel. The award was made for good diction on the air. It constitutes a double recognition: recognition of the excellence of Mr. Cross' work, and recognition of the important influence of the radio announcer upon American speech.

* * * *

Speech is by no means the only thing being affected by the development of

radio broadcasting. For example, New York City and its suburbs returned once more to daylight-saving time on April 28. At first thought, so far as metropolitan broadcasting stations are concerned, this seems to involve no problem; until we remember that these stations act as the point of origin for chain-system programs, and that many of the smaller chain stations serve areas where daylight time is anathema.

The National Broadcasting Company has met this problem by extending the time-on-the-air of its New York studios (except Sundays) an extra hour, from midnight to 1 A. M., each night. WEAJ will remain on the air the extra hour, WJZ shutting down as usual, at midnight.

* * * *

The element of time crops up again, in connection with ambitious plans recently announced by two of our major broadcasting interests: no less a project than the rebroadcasting of programs from England by the National Broadcasting, and from Germany and France by the Columbia System. In the latter case, still another problem, of far-reaching possibilities, enters in; the difference in languages.

Dr. Leon Levy, president of the Universal Broadcasting Company and secretary-treasurer of the Columbia System, has applied to the Federal Radio Commission for high-frequency channel allocations for the former's station WCAU; this to be the key station for picking up programs from France and Germany for retransmission over the Columbia chain, probably before the end of this year.

Meanwhile, Merlin H. Aylesworth, on his return from a recent European trip, announced that the National Broadcasting Company is looking forward to an exchange of programs with Great Britain. These plans have progressed to a point where C. W. Horn, general engineer of the N. B. C., remained abroad to assist Captain Eckersly, chief engineer of the British Broadcasting Company, in working out the details.

"We hope," Mr. Aylesworth said, "to be able to have the people of England and America listen in simultaneously on Thanksgiving Day this year to appropriate exercises originating in London, New York and Washington.

"We hope President Hoover and a representative of King George will address the English-speaking people of the world on that day.

"Regular international broadcast on announced schedules may follow. It depends entirely upon the working out of minor details."

W. Thomson Lee

Managing Editor



AT THE LEFT IS SHOWN THE INTERIOR OF ONE OF CHICAGO'S POLICE SQUAD CARS, WITH A RECEIVING SET LOCKED IN ON WGN'S WAVELENGTH; SHOWING MYRON EARL AND RICHARD FREDERICKS, OF THE DETECTIVE BUREAU TRAVELING AUTO SQUADS

BELOW IS PAT BARNES, ANNOUNCER AT WGN, WHO HAS INTERRUPTED MANY A PROGRAM IN ORDER TO APPRISE DETECTIVES BY HIS "SQUADS—ATTENTION!" THAT A CRIME REPORT IS COMING THROUGH



Squads— Attention!

Radio Enlists in Chicago's War on Crime

By ARTHUR STRINGER

"POLICE radio has passed its experimental state and has become an integral part of modern police equipment." (William Russell, Commissioner of Police, Chicago.)

With their feuds, murders, robberies, liquor trafficking and bombings, the gangsters and racketeers of Chicago have been waging a guerilla warfare, these many months, until their fact and exaggeration have colored the conversation of a nation.

When a Chicagoan goes to another city, in the ordinary course of commercial relationship, the ice of a first call is frequently broken by some such pleasantries as, "Well, where's the latest bullet holes in your hat?"

Conditions in the second city of the continent continued from bad to worse until the entire metropolitan area became aroused and definitely organized to down crime within the district. At radio station WGN the management was of the opinion that more criminals would be apprehended if police and detectives could arrive at the scene of a crime while the evil-doers were still in the immediate vicinity.

Radio, they concluded, could accomplish this feat and was the only means of communication that would make things so hot for the crooks that they would

either be captured or driven out of town. Having reached such a decision, WGN next offered its facilities to the police of Chicago to demonstrate that radio would prove a crime nemesis.

The Commissioner of Police agreed to a trial and the fleet of speedy, high-powered squad-cars was equipped with receiving sets, locked on WGN, day and night.

And then began the now famous call to the motorized and radioized police force of Chicago, "Squads Attention!" which marks the beginning of an order to proceed at a mile-a-minute clip, or faster, to the scene of a crime. It does not matter in the least what sort of a program is in progress over the *Tribune's* radio station, nor the hour. When a call comes from police headquarters the program is cut, and out goes the order, "Squads Attention!" Sometimes there are a dozen or more calls during an evening's tuning, in addition to those that are broadcast during the day.

The public service that WGN has pioneered is not only helping the police force of Chicago in its battle against crime, but it is serving to acquaint a goodly number of citizens with audible evidence of crime in their own city.

After several weeks of trial, the Police announced that radio had made good, and

would be continued as an aid to the detection of crime. Simultaneously Commissioner of Police Russell announced that the police department had obtained the use of the naval reserve station, NDS, in Lincoln Park, on Chicago's north side in order to supplant and extend the radio service inaugurated by WGN.

"So successful has radio service as a crime detector been that its use is to be extended to the whole Chicago area," he announced.

William O. Freeman, Chief of Police of Evanston, Ill., the home of Northwestern University, 15 miles north of Chicago, protects 65,000 inhabitants and many millions of dollars' worth of personal property in the luxurious homes of industrial leaders who spend their days in Chicago and their nights in Evanston, far from the turmoil of the Loop. Such wealth has always been an attraction to the yeggman, and Chief Freeman has need of all the assistance modern methods of crime prevention and detection offer.

When at its own expense WGN installed receivers in Chicago squad cars, Chief Freeman installed a receiver in his headquarters and another in a single squad car, with such excellent results

(Continued on page 90)



The Velvetone-29

A New Five-Tube A. C. Screen-Grid Tuner of Exceptional Design

By JAMES MILLEN and GLENN BROWNING

PROBABLY no industry in the history of our country has made such rapid progress as the art of radio reception and transmission. This has been largely due to the fact that the American public has generally accepted this new form of entertainment which brings the world of sound into the home. In fact, radio has so taken hold of the mass that it has become a major feature of a pleasant evening at home.

It seems only yesterday that we were satisfied if something in the nature of speech or music came out of the loud speaker; today, the sound emitted from the receiver must closely approximate an exact reproduction of the original, otherwise our ears immediately sense the distortion. When one stops to think of the changes that the sound has to undergo from the time it strikes the microphone at the transmitting studio, until the time it is emitted from the radio speaker, one wonders how it is possible to get natural reproduction. The microphone changes the sound waves into electrical currents, which must be amplified, and then radiated through space. Our receiver then picks up a minute fraction of this energy, amplifies it, unscrambles the speech or music frequencies, and finally the loud speaker emits sound which is a replica of the original. The receiver, if it is to perform faithfully its part in these trans-

formations, must not only have the component parts carefully designed, but each part must fit into the scheme of things in such a way that the quality of the received signals is not distorted.

This quality of received signal is probably the first requisite in every broadcast receiver. However, due to the increase in number and in power of the transmitting stations, a receiver must be selective as well. That is, it must possess the ability to respond to any one of some 80 or more channels on which broadcasting occurs, to the exclusion of programs being broadcast on channels adjacent to the one tuned in. This means that a number of tuned circuits must be employed in the design of the tuner device. In fact, if the receiver is to combine distance-getting ability together with selectivity and quality, three or four tuned circuits become necessary. This will readily be appreciated by the following illustration.

Assume that the field strength of various stations is as indicated in Fig. 1; that is, a local station broadcasting on 820 kc. has a signal strength of 500 microvolts per meter, while a semi-distant station on 830 kc. has a signal strength of about 2 microvolts per meter, etc. The receiver whose selectivity and sensitivity is represented by curve "A" would be able to receive the station transmitting on 810 kc. without interference from the local, but would not be able to receive the broadcast station on 830 kc., as the receiver does not have sufficient gain. However, if the sensitivity was increased without adding selectivity, so that sta-

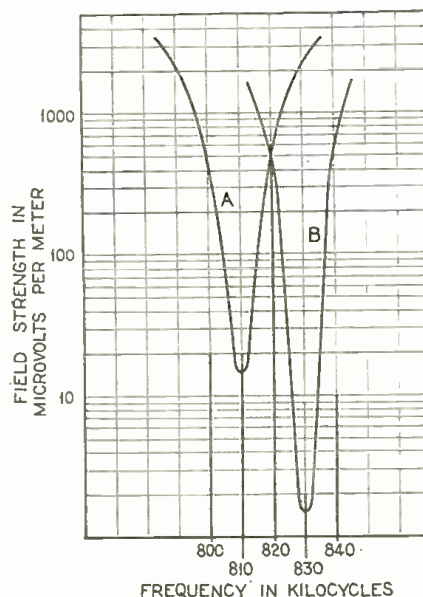

FIG. 1. THE CURVES INDICATED IN THE ABOVE CHART SHOW THE RELATIVE SELECTIVITY AND SENSITIVITY OF TWO DIFFERENT RECEIVERS

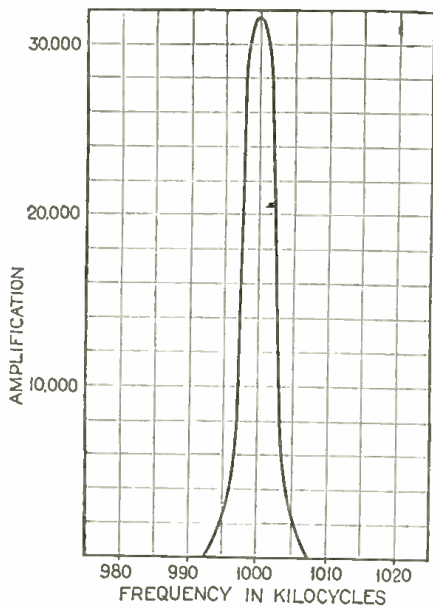

FIG. 2. THIS CURVE SHOWS THE SELECTIVITY EFFECT OF FOUR TUNED STAGES, EACH STAGE TUNED ALIKE

tions with a field strength of 2 microvolts per meter could be heard, this would be equivalent to lowering Curve "A" as a whole, and then interference would result.

On the other hand, the receiver with four tuned circuits, whose sensitivity and selectivity is represented by Curve "B," would be able to bring in any of the stations at will. Thus, it is apparent from the comparison that a set which may seem selective would, if the sensitivity was increased, actually be quite broadly tuned.

The writer has heard the question asked many times, "How can you get a radio frequency amplifier to tune sharply when you use the screen-grid tube?" The fact is that this tube will tune more sharply for a given signal strength than will the 227 or 201A; but, because the signal strength increases considerably, the apparent selectivity is lessened.

However, there is a definite limit to the sharpness of tuning unless the shape of the resonance curve is modified, for the high notes would not be amplified as

much as the lower ones. This can readily be observed by reference to Fig. 1. In the case of receiver "B," a 5,000-cycle note would be amplified only about one-third as much as a 100-cycle tone. Inasmuch as the ear responds as the logarithm of the intensity, the noticeable difference to the above distortion would be in the ratio of 1.47 to 1, which in all probability would not be at all objectionable.

In the design of the kit set to be described, the questions of selectivity and quality as well as distant reception have been carefully considered. Four tuned circuits have been used for the purpose of selectivity, and the tuning very slightly staggered so as to modify the resonance curve, giving it a flatter top with steep sides. This is shown in Figs. 2 and 3. Fig. 2 gives the tuning curve for the four tuned circuits, each circuit being exactly in tune with the previous one, while Fig. 3 indicates the effect of slightly staggering the tuning of the stages. It will be noted in the case where the stages are staggered, that the sides of the curve are more abrupt, and that the top is flatter; the amplification being less than is obtained with perfect alignment. In this manner the question of quality reception, as far as the tuner is concerned, is taken care of.

There are two sources of distortion introduced in the detection of signals by the detector. One might be called "frequency distortion," which is due to the detector being more efficient in rectifying, say, 2,000 cycles than it is in rectifying 200 cycles. This occurs in the case where a grid condenser and a large value grid leak is used, and can be practically eliminated by using either a grid leak of a megohm or less, or by using grid bias detection. The second source of distortion is introduced by overloading the detector.

If only one stage of audio amplification is used after the detector, grid bias detection is preferable, while if two stages are used, as far as the writer has been able to determine, there seems to be little difference which system is used, for in this case the last or power stage would seem to overload before the detector. The grid leak-condenser method has the ad-

vantage of considerably more signal strength, while the grid bias method tends to make the receiver tune somewhat sharper. Although the grid bias method is shown in the schematic diagram of the kit set, the set builder can use his own preference as to which he should employ.

In using four stages of amplification with the a.c. screen-grid tube, the problem of careful shielding was encountered. It was found, after a great deal of experimenting, that if the coils were shielded, condensers and tubes could be left outside the shielding, providing the leads to the tubes and condensers were short. Of course it was necessary to choose a condenser gang which had little capacity between the stator plates. It was also necessary to confine the radio frequency current flowing in each particular stage. This was done by placing the by-pass condenser and r.f. choke, in the plate circuit of each tube, inside the shield which contained the coil.

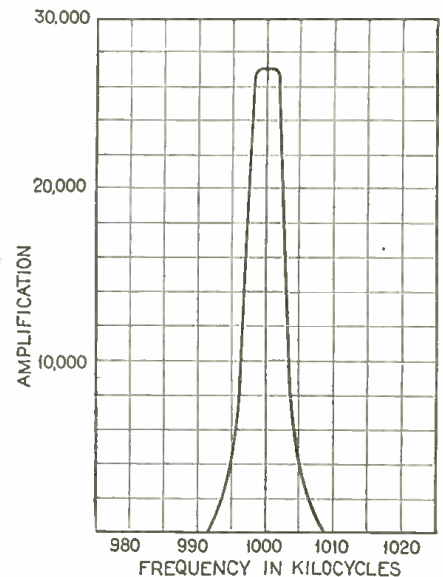
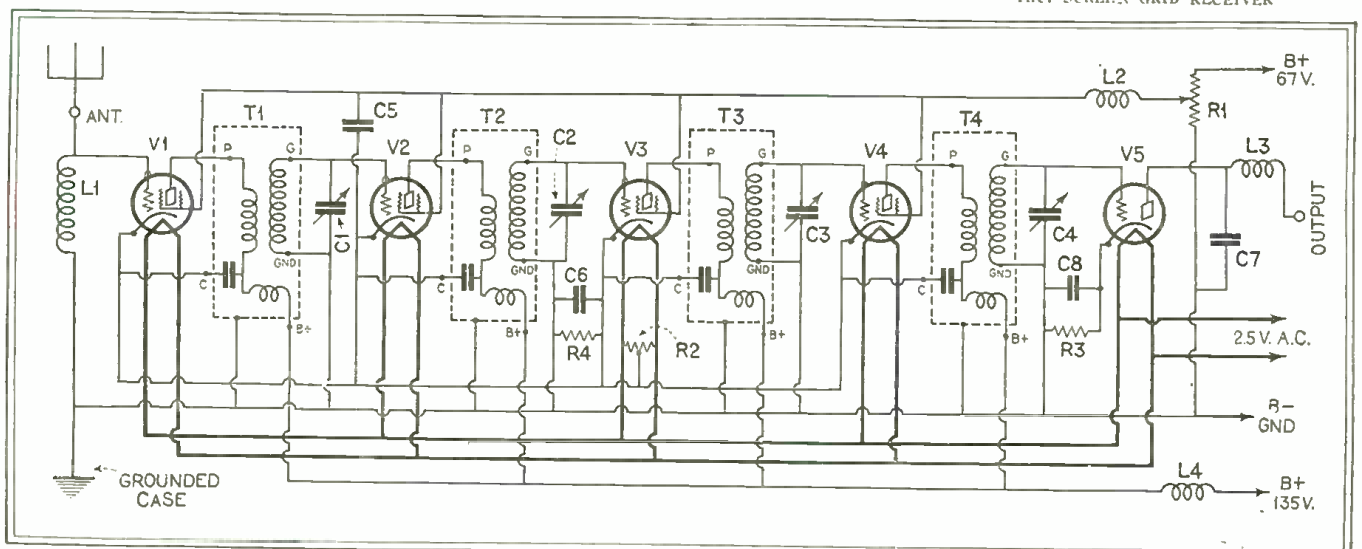

FIG. 3. HERE THE TUNING HAS BEEN SLIGHTLY STAGGERED TO OBTAIN A FLATTER PEAK—HENCE LESS SIDE-BAND CUTTING

FIG. 4. THE CIRCUIT OF THE VELVETONE A.C. SCREEN-GRID RECEIVER



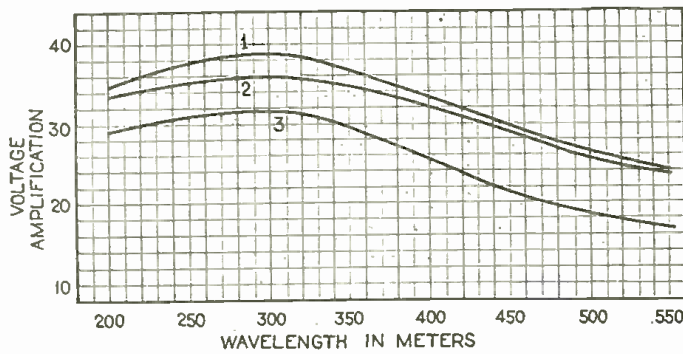

FIG. 5
THESE CURVES
ARE PLOTTED TO
SHOW THE
CHANGE OF VOLTAGE
AMPLIFICATION OF THE 1 1/4"
COIL, INSIDE AND
OUTSIDE OF SHIELD
CANS

The problem of the size of tuning coils to use, when it was necessary to shield, was determined by the following method. Assuming the size for the shields to be as large as physically practicable, we then measured the amplification of different sizes of coils when placed inside of the shields. It was found that a coil of 1 1/4" diameter was considerably the best under these conditions; though of course, with no shielding, two or three-inch diameter coils were somewhat superior.

The reader may be interested to note the change of amplification of the 1 1/4" coils inside and outside the shields. This is shown in Fig. 5.

In the course of our experiments, steel shields were tried, and Curve 3, Fig. 5, shows the result. It will be seen that the loss due to steel shielding is very much greater on the long wavelengths than on the shorter ones. This was carefully checked and certainly appears to be the case; the possible explanation being that the longer wavelengths (lower frequen-

cies) penetrate further into the shield than do the shorter wavelengths.

It was thought advisable to make a single control kit, and therefore an untuned antenna system was used, consisting of a radio frequency choke coil connected in the circuit as shown in Fig. 4. This system has an added advantage, besides the single control feature, in that the amplification of the radio frequency transformers falls off slightly on the long wavelengths, while the choke coil antenna system is more efficient on the long waves. Thus the combination gives a more even gain over the broadcast range than would otherwise be the case.

The actual construction of the four-stage tuned radio frequency kit set is quite easy, as the National Company supplies the base with the sockets in place, and the coils are obtainable in sets of four, all matched. The leads are brought out from the coils to a small terminal strip mounted on the bottom of each shield. To facilitate wiring, the

control grid lead is brought out in two places—one for connection to cap of the UY-224 and the other for connection to the stator plates of the variable tuning condenser.

The condensers used with the kit have small trimmer condensers built in each one, the purpose of these being to line up the condensers and compensate for any capacity in the wiring. Once the condensers are lined up at minimum capacity, they are so matched that they will turn within 1 per cent over the broadcast band. This accuracy in matching allows for about the right amount of staggering in the combined stages, provided that the error is not accumulative. To take care of this, the coils and the condensers are both numbered, so that the right coil is associated with the correct condenser. For convenience, one of the rotor plates in each condenser is slotted into sectors which may be adjusted by the constructor, should the occasion arise.

In wiring up the set, it is advisable to wire the filament circuit first. Number 16 gauge insulated wire, twisted together, should be used for this purpose. Do not use too small wire for the filaments of the five tubes combined take a total current of seven amperes. The center tap resistance should be connected to the second screen-grid tube, as shown in the schematic diagram, and the center of this resistance run to the cathodes of all the screen-grid tubes. Instead of using the

AS THIS PICTURE WIRING DIAGRAM SHOWS, ALL THE WIRING, WITH THE EXCEPTION OF THE LEADS TO THE CAPS OF THE SCREEN-GRID TUBES, IS MADE UNDERNEATH THE BASE

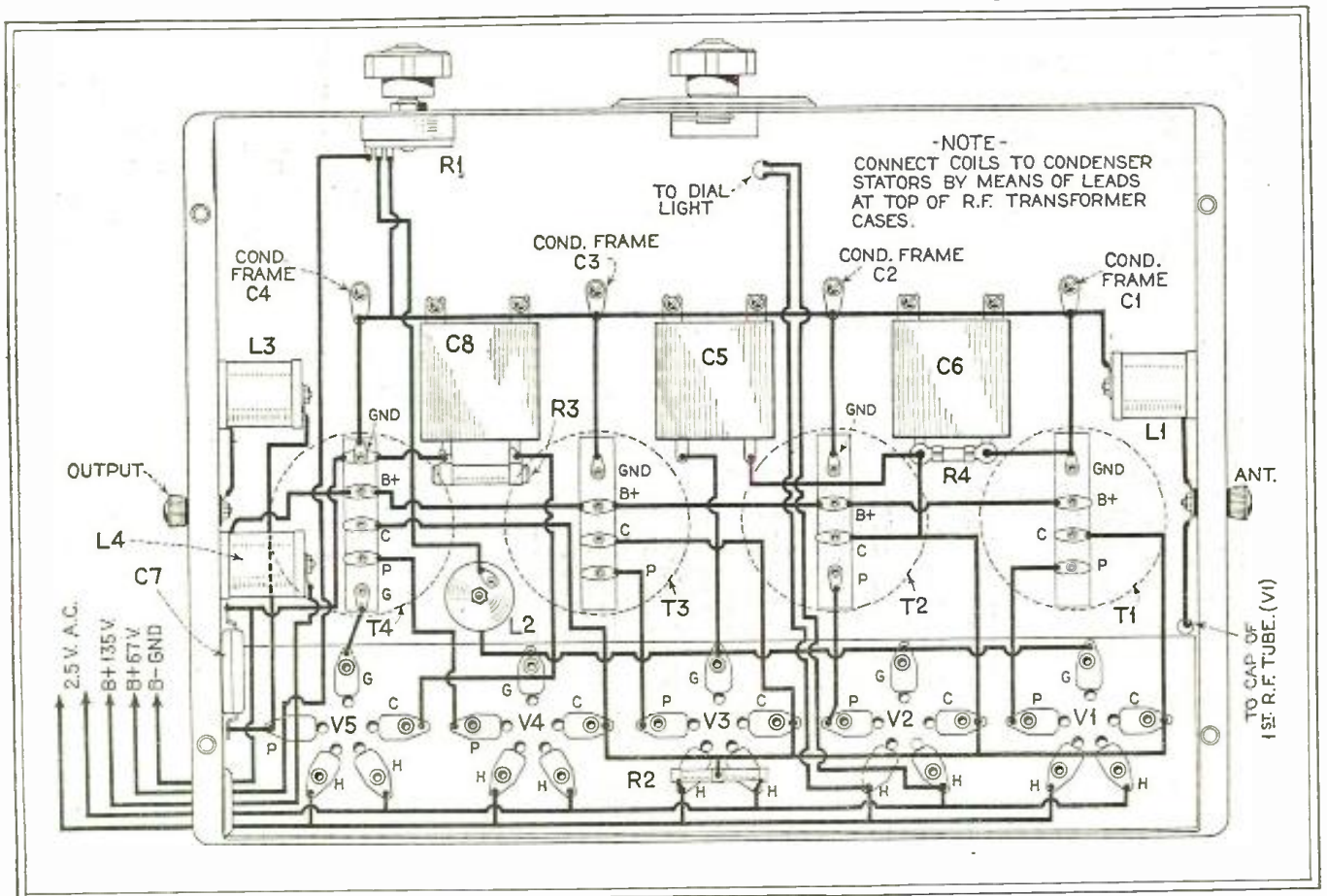

shield as a ground, it is better actually to run a piece of bare wire to the various ground connections. This eliminates the possibility of a high resistance joint which might make the receiver tune broadly; or, as in some cases, such joints have been the cause of sufficient inter-coupling to bring about set oscillation. This "ground" wire should be connected to the chassis in several different places.

It will be seen that even though one end of the coil is connected to the shield, a wire is also brought out so that the connection may be made to the ground terminals of each condenser. The by-pass condensers, in the shield compartments that hold the coils, have a connection coming out through the shield, marked "Cathode." This allows the by-passed radio frequency current to return directly to the cathode of the tube without going through the resistance used to obtain the

A REAR VIEW OF THE CONSOLE CABINET HOUSING THE VELVETONE TUNER, "245" POWER AMPLIFIER, DYNAMIC LOUD SPEAKER AND PHONOGRAPH TURNTABLE

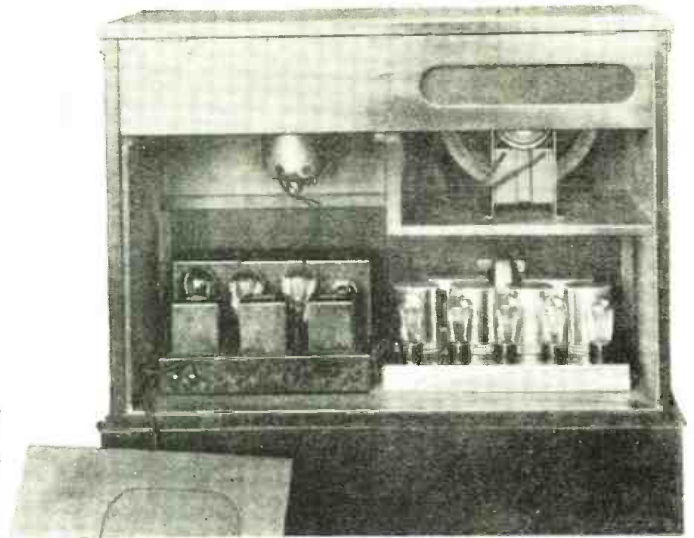

A FRONT VIEW OF THE CHASSIS, SHOWING THE EXTREMELY SIMPLE ASSEMBLY

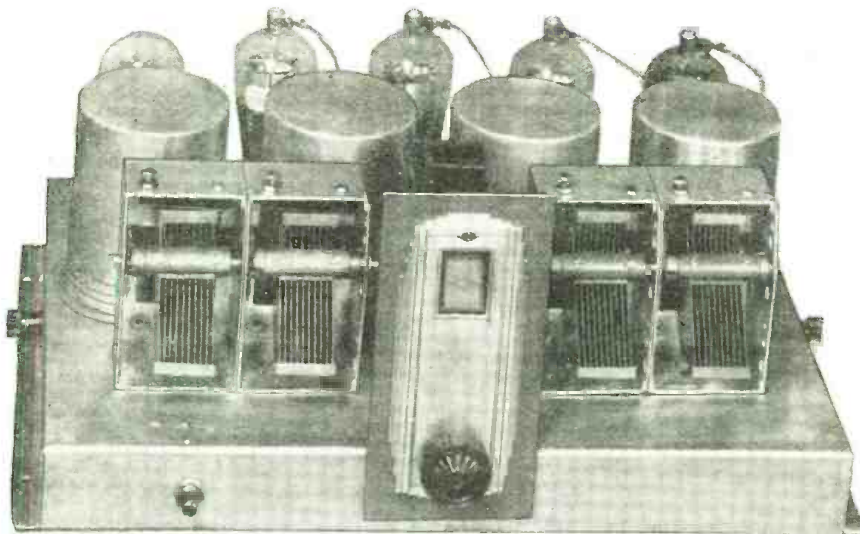

"C" bias. These leads should be run as directly as possible to cathode of the tube associated with the transformer. The radio frequency chokes, external by-pass condensers, and grid biasing resistors are located as shown in the layout of parts.

It will be noted that the mechanical design of the set is such that all the important grid and plate leads are exceptionally short.

If grid bias detection is used, as indicated, the set builder should experiment

somewhat with the amount of "C" battery for best results. Usually, with 45 volts on the plate of the detector, about six volts "C" battery is correct. However, this depends somewhat on the characteristics of the 227 tube used as a detector. If the constructor desires to use a grid leak and condenser for detection, the condenser (having a value of .00025 mfd.) should be connected between the grid and the tuned circuit, while the grid leak, having a value of about one megohm, should be connected between the grid and the cathode of the detector tube.

The volume control chosen is a potentiometer of 10,000 ohms, connected between the minus "B" and the plus "B"

67 volts. The variable arm goes to the screen grid of the tubes through the radio frequency choke coil. In this manner the potential on the screen grids may be varied over a range of from 0 to 67 volts. This type of volume control has the advantage of being completely out of any circuit where alternating current is flowing, and consequently simply regulates the amount of amplification of the screen-grid tubes. In most potentiometers the shaft is connected electrically with the movable arm so that it is necessary to use an insulating bushing where the volume control comes through the metal base.

This kit set may be used with any radio amplifier system the set builder may prefer. The writer has used the National Velvetone amplifier and power supply, which was described in the June, 1929, issue of RADIO NEWS. This amplifier has the correct voltage taps for the power supply and also has a separate transformer winding which will supply the filament current for the five heater type tubes used in the tuner. It is essential that a separate filament winding be used to supply the filaments of the tubes in the tuner. This audio amplifier consists of one stage of transformer-coupled audio amplification using a 227 tube, followed by a stage of push-pull amplification employing the new 245 tubes. It is not essential to use two stages of audio amplification, for if "C" bias detection is used, the output of the detector may be put into the primary of an audio transformer,

(Continued on page 81)

THE ELEMENTS OF A COMPLETE RADIO-PHONOGRAPH COMBINATION

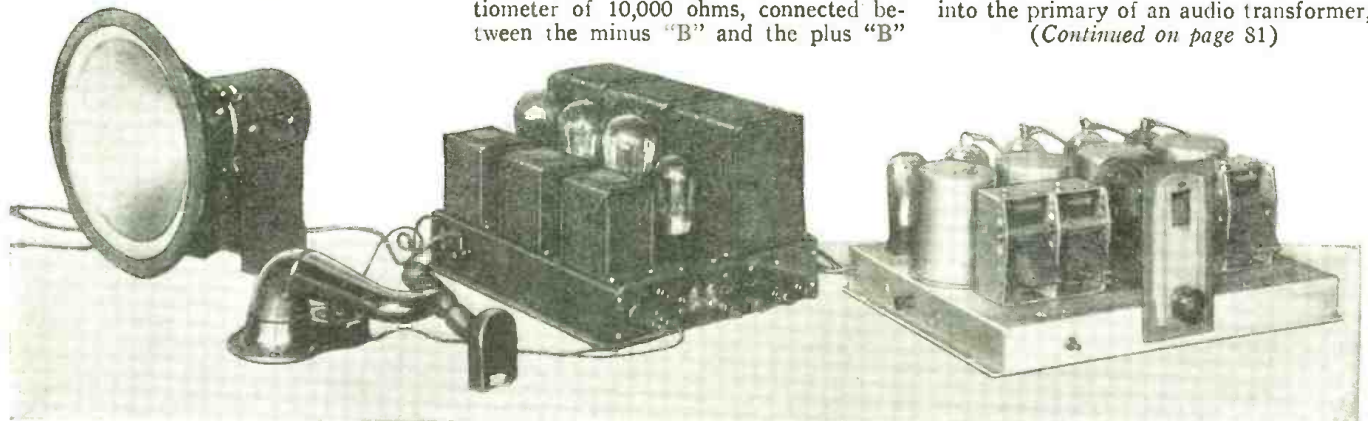

The Problems of Aircraft Radio

“Pay-Load” Versus Radio Equipment Is the All-Important Consideration

By ZEH BOUCK

RECENT engineering developments have tripled the utility of radio communication systems to aircraft. Radio in its relation to air traffic is no longer the relatively simple matter of transmitting intelligence, by telegraph or telephone, over short distances between a flying plane and the earth. The possibilities, as well as the problems, have multiplied with the development of the radio beacon, the radio altimeter, and the necessity for reliable long distance communication imposed by our modern express and passenger transport services.

The principal problem associated with airplane radio has always been the restrictions imposed by weight. The economic success of flying enterprises is a function of what is known as the “payload,” a term that almost self-explains itself as the amount of load that can be carried and charged for. A plane is capable of lifting a certain gross weight. Part of this gross weight is the avoirdupois of the pilot and the rest of the crew, the weight of the plane, the gasoline, oil, other necessary flying equipment. What is left is payload, and comprises passengers and express or mail. The weight of the radio equipment necessarily reduces the payload, and is a serious consideration in the case of small planes, and even in the larger planes when it necessitates a trained operator.

LOADING THE FLYING LABORATORY FOR A FLYING TEST.

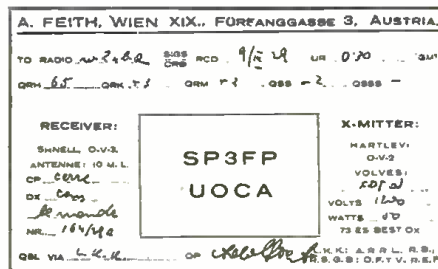

A CARD RECEIVED FROM AUSTRIA REPORTING RECEPTION OF W2XBQ'S SIGNALS.

The problem of weight has been attacked in three ways—by the design of light equipment, by limiting the plane to apparatus essential to its particular type of flying, and by eliminating the operator in every possible instance through the use of telephonic and visual receiving and transmitting systems. This last idea, however, does not always work out so well, due to the fact that telephone transmitting equipment for any given range is much heavier than a telegraphic transmitter, and the maximum reliable range is definitely limited.

It is the effective weight of radio equipment that must be considered, rather than its actual number of pounds as indicated on scales. This is invariably more than the real weight, but applies only to such portions of the radio apparatus that are placed outside of the plane in such a position that they offer wind resistance, and includes the antenna and

wind-driven generator. The additional wind resistance decreases the speed of the plane, with several concomitant effects. This is exactly the effect of added poundage which, requiring additional lift, increases the angle of attack, thereby multiplying the wind resistance and lowering the speed of the plane for a given motor speed.

A wind-driven generator may weigh only forty pounds, but when in operation may have the same effect on the maneuverability of the plane as fifty pounds carried inside of the fuselage. Due to such considerations it is occasionally desirable to employ battery power for telephone transmission with seven-watt tubes, rather than a wind-driven generator with an adequate filter system. A generator geared to the airplane motor may be considered the equivalent of a wind-driven generator, only it has the advantage of being more effectively turned up on the ground for emergency transmission following a forced landing. However, a wind-driven generator may float a small storage battery across a low tension winding, and can be used as a dynamotor for ground transmission. A standard dynamotor also provides a reliable airplane radio power supply but is less efficient than the wind-driven combination last described.

As already implied, considerations of weight affect directly the selection of

THE FLYING LABORATORY SHORTLY AFTER TAKING OFF.



telephonic or telegraphic apparatus. The table on the following page gives a good idea of the relative weights of telephonic and telegraphic transmitters for distances covered reliably by different powers. One hundred and fifty pounds have been added to the actual weight of the telegraphic apparatus, as the weight of the average operator. It is seldom desirable to require the pilot to operate a code transmitter, even when he possesses the necessary training. In large transport planes, carrying a relief pilot, it would be reasonable to demand telegraphic ability of both pilots, and in such cases the 150 pounds should be deducted from the telegraphic weights, adding considerably to the argument in favor of code sets.

Generally well corroborated figures estimate that for a given antenna power an effectively modulated telephone signal will carry only about one third the distance of a similarly powered telegraphic signal, while the weight of the telephone equipment will be about 20 per cent. greater than that of the telegraphic apparatus, and proportionately more complex. It may be possible to improve this ratio by increasing the percentage of modulation, but this will require a crystal-controlled oscillator, buffer and linear amplifiers, with increased weight and complications, hardly justified by airplane technique.

While the figures suggested in the above table will vary with different frequencies, the range generally increasing with the frequency, they will be found relatively correct though compensation may have to be made for distortion effects experienced in 'phone transmission on the very high frequencies.

The weight of receiving equipment has been minimized, and an adequate receiver for the reception of 'phone and beacon signals in the 285-350 k.c. band, including antenna and accessories, should not weigh more than 35 pounds.

Ignition Noise and Interference

The engine with its associated noises offers two serious problems. The ignition system sets up an electrical inter-

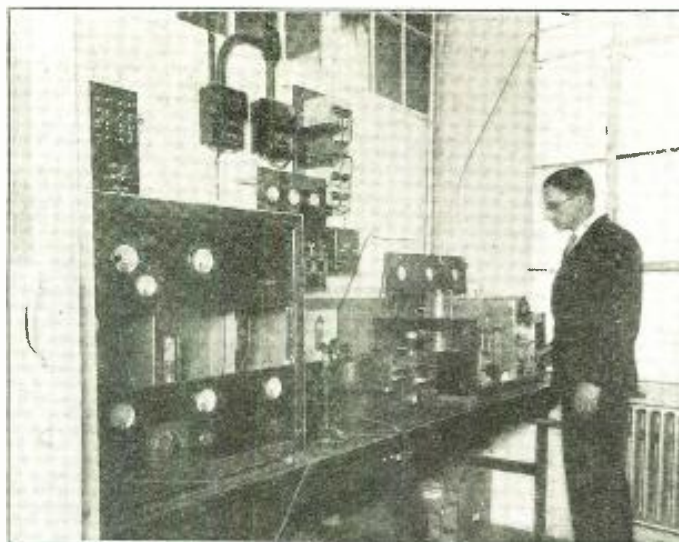

W2XBP, THE EXPERIMENTAL GROUND STATION OF "PILOT"



SHOWING TRANSMITTER AND RECEIVER SUSPENSION IN THE PLANE

ZEH BOUCK, AUTHOR OF THIS ARTICLE, AND HIS PILOT, LOUIS MEIER, NAVAL RESERVE OFFICER, IN FRONT OF THE PILOT FLYING LABORATORY

ference that is particularly difficult to minimize, while the vibrations of flight are responsible for microphonic noises beyond imagination of the broadcast listener.

The ignition interference is electrical in nature, and may be overcome to a satisfactory extent by complete shielding of the entire ignition system. It is not sufficient to shield merely the high tension leads. The low tension wiring, even the magneto switch, must be shielded. Also the spark-plugs must be shielded. Unshielded spark-plugs, with otherwise perfect shielding, will result in noise conditions that will render aural reception impossible over distances reasonably encountered in everyday flights.

It is worth while noting that a superheterodyne receiver, operating from a loop antenna, is relatively immune to ignition interference, and may be operated satisfactorily in a partially shielded ship. This is due to the fact that the loop can be located outside of the immediate electrostatic and magnetic fields, and that practically no pickup of the high frequency spark QRM is effected in the low frequency intermediate amplifier. At the time when the Graf Zeppelin first visited this country, the Pilot Flying Laboratory was experimenting with partial ignition shielding. With the cooperation of radio broadcasting station WOR, a description of the great dirigible was broadcast during its flight over New York City. While flying over the naval base at Lakehurst, New Jersey, we received reports of the position of the Graf Zeppelin from broadcast stations over one hundred miles away on the superheterodyne (without a trace of spark interference) while reception on another set was impossible, due to the ignition QRM.

Microphonic disturbances will not, of course, be affected by shielding or other electrical corrections, but are reduced by the careful suspension of transmitting and receiving apparatus. The suspension or mounting should be sufficiently rigid to preclude the possibility of excessive displacement in rough landings. Such suspension eliminates microphonics caused by vibrations transmitted through the frame of the plane, but has no effect

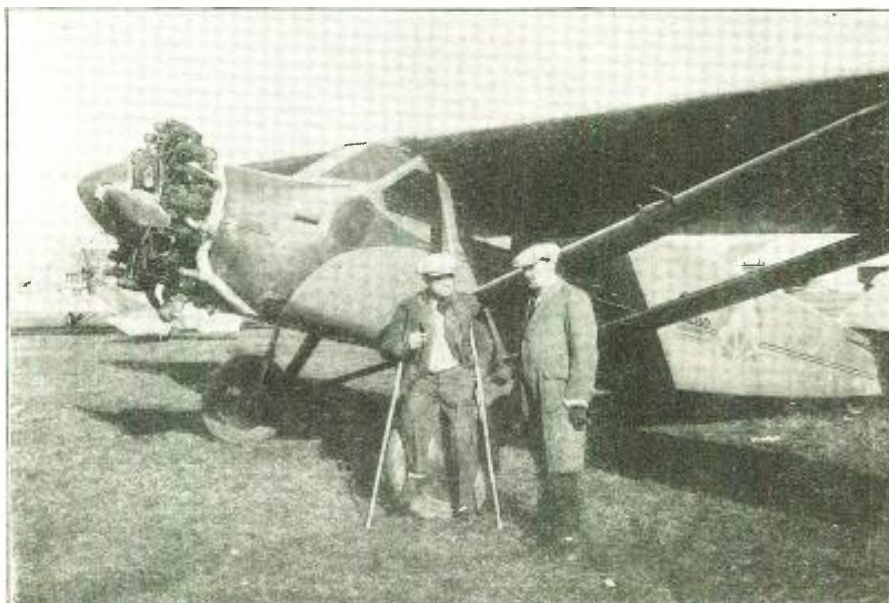

whatever upon the equally important source of microphonics by sound transmission through the air. The unusual amount of noise existing even in a well muffled cabin plane is sufficient to vibrate shielding, wiring, tube elements and condenser plates, with a resulting modulation of both incoming and outgoing waves.

It is almost needless to say that aircraft transmitting and receiving apparatus should be sturdily constructed. Semi-flexible wire should be used for wiring, and laced wherever possible. The condenser plates should be at least .0025 inch stock, and more generously spaced than is the custom in the conventional receiver design. The capacity variations with plate movements vary inversely as the square of the distance separating the plates, and so wide spacing is quite effective in lowering modulation.

Ordinary battery receiving tubes are quite microphonic, and a considerable reduction in noise can be effected by using special tubes. With the co-operation of the Arcturus Radio Tube Company, tests made in the Pilot Flying Laboratory

future. Non-microphonic tubes were made by Arcturus for the Byrd South Pole expedition, and similar tubes can undoubtedly be secured from the same company on special order.

Cushion sockets should *not* be employed in airplane transmitters and receivers.

Antennas

The most familiar and commonly used aircraft antenna is the trailing wire, consisting of several hundred feet of weighted wire unreel when it is desired to transmit or receive. It is excellent for both purposes, but possesses directional effects that are often pronounced, and which render it unsuitable for beacon work, which requires a perpendicular aerial. It is also dangerous, and easily lost.

A vertical pole aerial, of the type used for beacon and general reception is shown in Fig. 1. This consists of a pole, generally streamlined, ten feet long and mounted at the most convenient place above the fuselage. The fuselage is used as a counterpoise. As relatively small

receive change-over switch. The fuselage is used as a counterpoise. This antenna is highly effective for both transmission and reception, and is only slightly directional.

With the exception of loop systems, the fuselage of the airplane is used as a counterpoise. This necessitates the bonding of the entire metallic structure of the plane, with the exception of thoroughly insulated parts. This is desirable for three reasons—the reduction of the resistance of the antenna system, the elimination of a fire hazard caused by sparks induced across adjacent conductors during transmission, and the elimination of microphonics caused by the rubbing together of poorly connected metallic surfaces in the antenna field. Control wires flopping against or otherwise making poor contact with other metal surfaces will cause very noisy transmission and reception.

Wavelengths

Commercial aircraft stations are operating at present on the international assignment between 285 and 315 k.c. for communication purposes and between 315 and 350 k.c. for beacon reception. Aircraft should certainly be equipped for reception on this frequency band, and for transmission when justified. However, until aircraft radio becomes a better established procedure, planes equipped for transmitting will do well to design their equipment for transmission on the 500 k.c. ship band and the 6.675 k.c. mobile band as well. The ship band provides a reliable response to distress signals, and the low wave band is almost a necessity for long distance transmission with the low powers that will generally be employed on all but the largest transports. The 6,675 k.c. band is sufficiently close to the amateur 7,000 k.c. band to enlist the entire amateur fraternity in the airplane cause, and will prove of incalculable value in many emergency transmissions. An airplane grounded by a forced landing will ex-

POWER (Antenna)	AIRPLANE RADIO RANGES AT 300 K.C.			
	TELEPHONE (with operator)		TELEGRAPH	
	Weight	Distance	Weight	Distance
50 watts	100 lbs.	50 miles	250 lbs.	200 miles
100	175	100	300	300
150	200	120	325	350
200	250	135	350	400
250	275	150	375	450

established that the best tubes, from a non-microphonic point of view, readily available for airplane purposes, are the A.C. type Y27 2.5-volt tubes. These tubes have a heavy cathode structure, contrasting with the light, easily shaken filament of the battery tubes. They draw a rather heavy heater current and require an appreciable time before heating to operating temperature. However, the Arcturus type 127 comes up in seven seconds.

The following table indicates the ratio in which microphonics are reduced by employing cathode tubes.

Audibility tests were made on different tubes under different cushioning conditions, the degrees of sound being given arbitrary but proportionate numbers. Arcturus type 127 (five prong 2.5 volts) and type 48 (four prong 15 volts) tubes were most free from microphonic disturbances and reception was possible without cushioning other than that inherent in a cushion-type socket. Reception was impossible with the 201A type of tube without careful cushioning. The relative noise levels were as follows:

TUBE	UNCUSHIONED	CUSHIONED
201A	36	7
48	19	3
127	14	1.5

The noise level on the 127 tube is practically identical with the mechanical noise level of the plane and, for this reason, may be considered as negligible, the mechanical noise itself being a limiting factor in reception.

It is probable that special airplane tubes will be manufactured in the near

amounts of energy are picked up by a ten-foot antenna, high r.f. gain, in the neighborhood of 2,500, is required of the receiver for effective operation over reasonable distances.

A third type of antenna system is shown in Fig. 2, which shows the aerial used on the Pilot Flying Laboratory for general transmitting and receiving. This is really a modified T. Masts on the wing tips support a straight stretch of about forty feet. Two leads are brought down from each end of the straight top converging in a V at the fuselage. They are brought in through lead-in insulators on each side of the fuselage, and joined inside of the cabin, where a single wire leads to the antenna post on the send-

THE VERTICAL ROD ANTENNA USED FOR RADIO BEACON AND TELEPHONIC RECEPTION

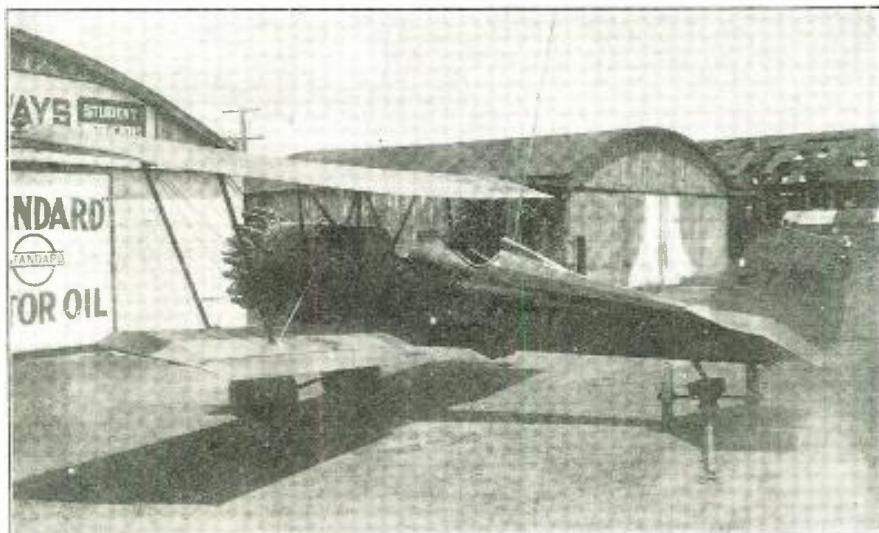

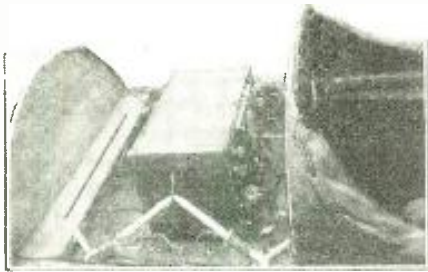

COMPACT RECEIVER MOUNTED IN OPEN PLANE FOR BEACON RECEPTION

perience no difficulty in raising an amateur station, where a ship or plane station is quite beyond the range of the low-powered low-frequency transmitter. Also communication with amateurs along the route of flight, during the few years that must intervene before the establishment of a network of airplane ground stations, will be highly desirable in ascertaining weather conditions and reporting positions.

The 6.675 k.c. band is a highly effective airplane transmitting frequency, and relatively great distances can be covered reliably with low power transmitters. Skip distance effects are not particularly prominent on this frequency, and a transmitter putting fifty watts into an adequate antenna should have no difficulty in pushing through a good signal, in the day time, to a receiver one thousand miles away.

On the lower frequencies, the reliable range is about that indicated in the table in the earlier part of the article.

The Radio Beacon and Altimeter

We described the radio beacon in the last number of RADIO NEWS, and readers interested in this invaluable radio adjunct to aerial navigation are referred to this previous article. There are next to no problems unsolved in radio beacon technique. It is an instrument requiring no adjustment or attention on the part of the pilot, and it shows him when he is on his course, and the amount and direction of variation when he is off course. Beacon stations are rapidly being erected along the prominent air lanes of this country. The radio beacon is as practical and perfect today as the ordinary magnetic compass.

The radio altimeter is still in the experimental stage, but is rapidly assuming

AN AIRPLANE RECEIVER DESIGNED FOR THE 285-350 K.C. BAND

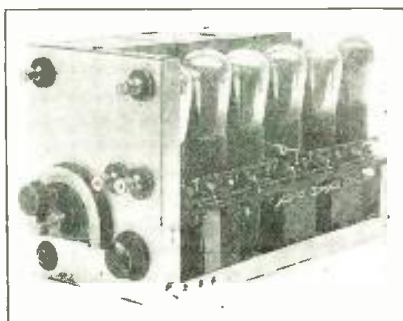

the aspects of a practical device. There are several principles whereby radio apparatus can be made to indicate the distance a plane is from nearby obstacles such as mountains or the ground. The barometric altimeter used today, indicates only the height above sea level and is subject to discrepancies caused by changes in atmospheric pressure which varies with different localities. The barometric altimeter may indicate the correct distance above sea level at the starting point and be five hundred feet out of the way at the end of the flight. At no time does it indicate the height above ground, except when the ground is at sea level.

THE true story of Television—gleaned from those who have most aided in its birth—will be told in RADIO NEWS for August and succeeding months. These stories are to be prepared by Arthur H. Lynch, in collaboration with

- Dr. Lee DeForest, Inventor of the Vacuum Tube.
- Dr. Alfred N. Goldsmith, Past President of the I. R. E., Chief Engineer of the R. C. A., in charge of its Television work.
- D. E. Replogle, Chairman, Radio Manufacturers' Television Committee.
- Dr. C. Francis Jenkins, Inventor of the Jenkins Television System.
- James Millen, General Manager of the National Company, whose work on television reception has created world-wide interest.

The radio altimeter will show the exact distance of the plane above whatever is under it. One possible radio altimeter works on the principle of reflection, somewhat after the manner of oceanic depth indicators the readings of which are a function of the time element involved in the transmission of a sound wave to the bottom of the ocean and the reception, on the boat, of its echo. Another possible radio altimeter operates by means of changes in capacity of an electrical circuit with the approach to earth. As the amount of capacity variation for a given change in distance (altitude) varies inversely with the square of the distance of the plane above the earth, this latter system will probably be practicable only when rather close to the ground.

It is not difficult to arrange electrical systems that will respond in different ways as the ground comes near or recedes. The difficulty lies in expressing these changes on a sturdy instrument reading in feet.

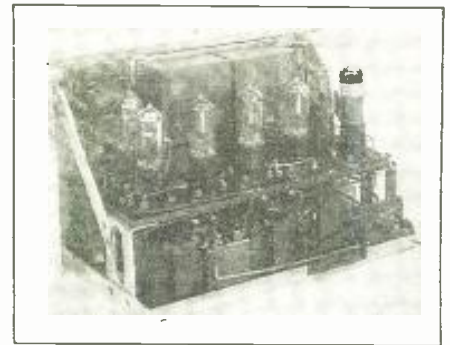

AN AIRPLANE RECEIVER DEVELOPED BY THE BUREAU OF STANDARDS

There is no adequate justification for the small plane carrying radio transmitting apparatus. To carry a really effective transmitter, the profit making ability of the small plane would be seriously curtailed. However, all planes should be equipped with radio beacon receiving sets which, with telephone receivers, would enable the pilot to receive, not merely the visual directional signals, but radio-telephone broadcasts of weather conditions.

The ideal equipment for planes today would comprise the following equipment, in the opinion of the writer:

- Complete ignition shielding.
- One special airplane receiver covering the 285 to 950 k.c. airplane band, using shield grid tubes and having an r.f. gain of at least 2,500.
- A plug-in-coil receiver covering from 23,000 k.c. to 950 k.c. The Pilot Super-Wasp is ideal for this purpose, with an extra set of coils wound for the 500 k.c. to 950 k.c. band.
- A modified T antenna for transmitting both in the air and following a possible forced landing.
- A trailing wire antenna which, when let down about fifteen feet, will function quite satisfactorily for beacon reception, and, when fully extended, will probably be superior to the T antenna for the lower frequency transmissions.

The power should be supplied by a retractable wind driven generator floating a storage battery across the low tension winding.

This apparatus would not be unreasonable in its demands on space and weight, and provides that factor of safety to commercial flying only with which it is possible to compare air travel with older methods of transportation.

CHECKING UP ON AIRPLANE TRANSMISSION WITH A PORTABLE SET ON THE FLYING FIELD

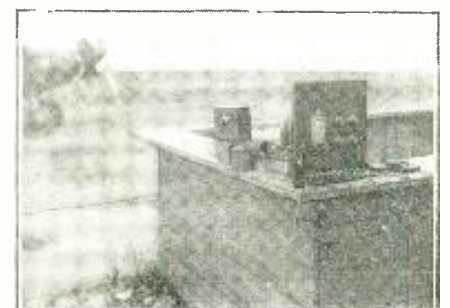

The Story of Our A Stirring Antarctic Rescue,



ST. LOUIS POST-DISPATCH

COMPLETE EDITION

ST. LOUIS, MONDAY, MAY 6, 1929—16 PAGES.

Latest Margin of One REPARATION PLAN
dWar CLAIMED AGAINST OF YOUNG CHAFES
Loay. Also DEBENTURE PLAN FRENCH PRESS

Before Jealousy and M...

**BYRD DOG DRIVERS
END PERILOUS TRIP**
Dash 50 Miles on Last Day's
Run Back to Base Over
Trail Laid-Toward Pole.

CAUGHT IN 60-MILE STORM
Pitching Tests Just in Time
They Weathered Blast While
Dogs Burrowed in Snow.

COMMANDER RICHARD E. BYRD, COMMANDER-IN-CHIEF OF THE BYRD ANTARCTIC EXPEDITION AND LEADER OF THE RESCUE PARTY

to Him for Asking
"To Do What the
United States Refuse to

LS NEW FIGURES
ERMAN AMERICAN

of Latest Proposal to
be Distributed to Mem-
bers of Experts Commis-
sion Today.

**BYRD TO FLY TO AID
OF MOUNTAIN PARTY**

Orders Dog Teams to Go Over-
land to Three Men Marooned
on Rockefeller Range.

NO SIGNAL FOR THREE DAYS
Radio Fails Gould, Balchen and
June—Crack-Up of Plane Possi-
ble but Held Unlikely.

By RUSSELL OWEN.

CHICAGO, May 5.—The New York Times Company and The St. Louis Post-Dispatch, through their published papers, throughout the world, announce that they have secured the exclusive rights for the publication of the story of the rescue of the three men marooned on the Rockefeller range in Antarctica. The story is being published in the St. Louis Post-Dispatch and the New York Times. The rescue party, led by Commander Richard E. Byrd, has successfully completed its mission and returned to the base. The three men, Larry Gould, Harold G. G. Balchen, and Harold G. June, were rescued after a three-day search. The rescue party, consisting of 12 men and 20 dogs, had to travel over 50 miles to reach the marooned men. The rescue was a remarkable feat of endurance and courage.



MALCOM HANSON, BYRD'S RADIO EXPERT—RESCUER

**BYRD RADIOS BASE
THAT 'ALL IS WELL'
ON THE MOUNTAINS**

Rescue Plane Will Start From
Little America in the First
Flying Weather.

DOG TEAMS ARE SENT OUT
Would Meet Commander and
Companions Should They
Start Back by Sled.

JUNE DESCRIBES STORM
Tells How 150-Mile Wind Wrecked
Plane of Party on Rockefeller
Range.

By RUSSELL OWEN.
Copyright, 1929,
By The New York Times Company and The
St. Louis Post-Dispatch. All Rights Reserved.
Published by the St. Louis Post-Dispatch
and the New York Times Company.
LITTLE AMERICA, Antarctica,
March 20—Commander Byrd is re-
lated under the walls of the re-

UNLOADING ONE OF THE PLANES FROM THE S. S. CITY OF NEW YORK



DEAN SMITH, PILOT OF THE RESCUE PLANE

Cover for This Month as told in Newspaper Headlines



LARRY GOULD, GEOLOGIST AND SECOND IN COMMAND OF THE BYRD PARTY—RESCUED



BYRD'S DOG TEAMS HITCH UP FOR DASH TO ISOLATED MEN
HOVER FORCES FACE DEFEAT IN SENATE OVER DEBENTURES
HOUSE ON MAIL FARM
HOVER FORCES FACE DEFEAT IN SENATE OVER DEBENTURES
HOUSE ON MAIL FARM

HOVER FORCES FACE DEFEAT IN SENATE OVER DEBENTURES
HOUSE ON MAIL FARM
HOVER FORCES FACE DEFEAT IN SENATE OVER DEBENTURES
HOUSE ON MAIL FARM

HOVER FORCES FACE DEFEAT IN SENATE OVER DEBENTURES
HOUSE ON MAIL FARM
HOVER FORCES FACE DEFEAT IN SENATE OVER DEBENTURES
HOUSE ON MAIL FARM

HOVER FORCES FACE DEFEAT IN SENATE OVER DEBENTURES
HOUSE ON MAIL FARM
HOVER FORCES FACE DEFEAT IN SENATE OVER DEBENTURES
HOUSE ON MAIL FARM

HOVER FORCES FACE DEFEAT IN SENATE OVER DEBENTURES
HOUSE ON MAIL FARM
HOVER FORCES FACE DEFEAT IN SENATE OVER DEBENTURES
HOUSE ON MAIL FARM

HOVER FORCES FACE DEFEAT IN SENATE OVER DEBENTURES
HOUSE ON MAIL FARM
HOVER FORCES FACE DEFEAT IN SENATE OVER DEBENTURES
HOUSE ON MAIL FARM

HOVER FORCES FACE DEFEAT IN SENATE OVER DEBENTURES
HOUSE ON MAIL FARM
HOVER FORCES FACE DEFEAT IN SENATE OVER DEBENTURES
HOUSE ON MAIL FARM

HOVER FORCES FACE DEFEAT IN SENATE OVER DEBENTURES
HOUSE ON MAIL FARM
HOVER FORCES FACE DEFEAT IN SENATE OVER DEBENTURES
HOUSE ON MAIL FARM

BYRD'S DOG TEAMS HITCH UP FOR DASH TO ISOLATED MEN
 Commander Orders Run Over the Ice as Wind Blows His Attempted Flight.

HOVER FORCES FACE DEFEAT IN SENATE OVER DEBENTURES
 Administration Leaders See Little Chance to Win an

HOVER FORCES FACE DEFEAT IN SENATE OVER DEBENTURES
 Administration Leaders See Little Chance to Win an

HOVER FORCES FACE DEFEAT IN SENATE OVER DEBENTURES
 Administration Leaders See Little Chance to Win an

HOVER FORCES FACE DEFEAT IN SENATE OVER DEBENTURES
 Administration Leaders See Little Chance to Win an

HOVER FORCES FACE DEFEAT IN SENATE OVER DEBENTURES
 Administration Leaders See Little Chance to Win an

HOVER FORCES FACE DEFEAT IN SENATE OVER DEBENTURES
 Administration Leaders See Little Chance to Win an

HOVER FORCES FACE DEFEAT IN SENATE OVER DEBENTURES
 Administration Leaders See Little Chance to Win an

The New York Times

Copyright, 1929, by The New York Times Company.
 NEW YORK, WEDNESDAY, MAY 8, 1929.

HOVER FORCES FACE DEFEAT IN SENATE OVER DEBENTURES
HOUSE ON MAIL FARM

HOVER FORCES FACE DEFEAT IN SENATE OVER DEBENTURES
HOUSE ON MAIL FARM

HOVER FORCES FACE DEFEAT IN SENATE OVER DEBENTURES
HOUSE ON MAIL FARM

HOVER FORCES FACE DEFEAT IN SENATE OVER DEBENTURES
HOUSE ON MAIL FARM

HOVER FORCES FACE DEFEAT IN SENATE OVER DEBENTURES
HOUSE ON MAIL FARM

HOVER FORCES FACE DEFEAT IN SENATE OVER DEBENTURES
HOUSE ON MAIL FARM

HOVER FORCES FACE DEFEAT IN SENATE OVER DEBENTURES
HOUSE ON MAIL FARM



BERNT BALCHEN, PILOT—RESCUED

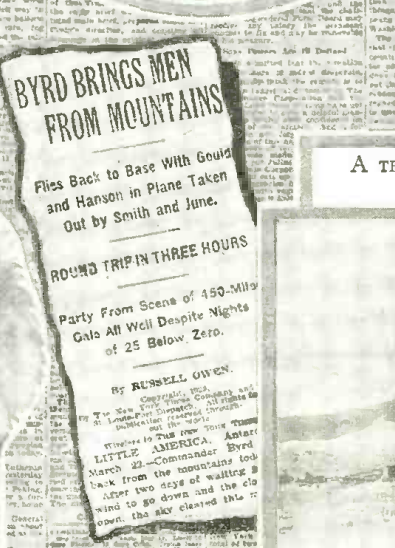

HAROLD JUNE, PILOT—RESCUED

GOULD DIARY TELLS OF WAIT FOR RESCUE
 Three in Mountains Got Byrd's Messages by Radio Day After Day, but Could Not Reply.

PREPARED FOR TREK BACK
 Cooked Food and Put Fuel in Fire Extinguishers for Stoves on Long Sled Haul.

THEN PLANE ZOOMED ALOFT
 And Commander Came Down Out of Sky to His Marooned Men, Ending Anxiety of All.

BYRD BRINGS MEN FROM MOUNTAINS
 Flies Back to Base With Gould and Hanson in Plane Taken Out by Smith and June.

ROUND TRIP IN THREE HOURS
 Party From Scene of 450-Mile Gale All Well Despite Nights of 25 Below Zero.

BYRD BRINGS MEN FROM MOUNTAINS
 Flies Back to Base With Gould and Hanson in Plane Taken Out by Smith and June.

A TEMPORARY BASE IN THE ANTARCTIC WASTES

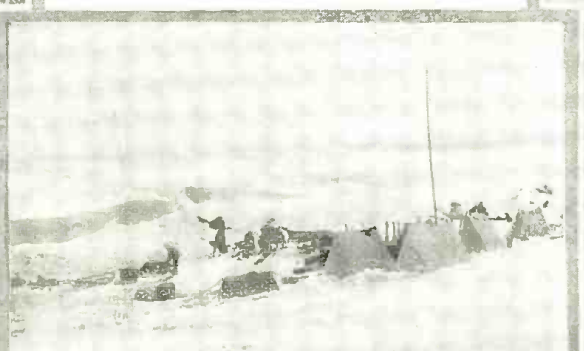

BYRD BRINGS MEN FROM MOUNTAINS
 Flies Back to Base With Gould and Hanson in Plane Taken Out by Smith and June.

Our Fifty-Dollar Prize-Winning Short-Wave Receiver

By E. T. SOMERSET

Associate Member, I. R. E.

WHEN the shield-grid tube first came into use in England I was immediately attracted to it as a means of radio-frequency amplification at signal frequency, owing to its remarkable stability, and in the very first receiver that I constructed I discovered that this really was true. I did find that I was getting practically no amplification from it below about 25 meters; but after some experimentation in including radio-frequency chokes (or to use their correct name, "decoupling resistances") in the plate and control grid leads with necessary by-pass condensers. I found that this trouble vanished. But I could never get rid of the general noise produced by using two stages of audio amplification, and the idea came to my mind of using more amplification at signal frequency and in this way the receiver I am about to describe came into being. Upon referring to the theoretical diagram it will at once be apparent that the first r.f. stage is tuned and the second stage untuned—thus getting rid of one tuning control.

The reason I chose this particular arrangement is really for convenience in design, as, if the order of things were to be reversed it would be found that a somewhat lop-sided set-out of the front panel would result. In my own receiver the panel is 28 inches long by 8 inches high, and the first-stage screening box measures 9 inches by 9 inches and the second stage 6 inches by 6 inches, the discrepancy being explained by the fact that the middle tuning condenser, C4, has nothing to do with the second r.f. stage, but tunes the detector grid, and consequently must not be included in the second r.f. shielding compartment. This will be seen in the suggested layout for use with two UX-222 tubes; it was no use my giving my own layout for my American friends, as the English shield-grid tubes' connections are different.

Particular attention should be paid to R1 and an increased voltage, by adding a small "B" battery in series, will be required to supply the plate of V1 to make up for the drop in voltage across this 10,000-ohm resistance. The next item of note is C3, and it may be asked "why is this variable?" The answer is twofold; the shield-grid tube appears to amplify atmospherics at audio frequencies when these are bad, and by cutting down the capacity at this point enjoyable reception can often be had where it could not with a fixed condenser of, say, .0001 mfd. The other reason is that it will most probably be found that, when listening above 60 meters, one cannot get the

BY his practical application of two screen-grid tubes to a short-wave circuit, Mr. E. T. Somerset, of Sussex, England, has won the prize offered in our April, 1929, issue. It is with pleasure that we present Mr. Somerset's description of his receiver.

detector tube out of oscillation without again cutting down the capacity, as there are usually too many turns on the tickler coil on commercial inductances for use with two stages of r.f. Here I am using a "Hammarlund" Junior of 85 mmfd. in this position.

The aerial coil is easily made, but it must be astatic so as to cut down the area of its field and thereby not lose energy in the surrounding shielding. It is wound on an unwound coil form of General Radio manufacture, type No. 277-U, with No. 16 gauge enameled copper wire. For 5SW reception it will be found that 2 turns clockwise and 2 turns counter-clockwise are just right and will do admirably for W2XAF and KDKA on 63 meters. L2 and L3 coils can be purchased ready-made in small diameter type from Aero Products, Inc., or they can be made at home. Tube base coils can also be used with advantage, especially if it be desired to make an attempt to get down to 10 meters. In this connection it will most probably be advisable to use

a baseless detector tube and thus cut out the capacity in the tube's base and in the tube socket. Should the constructor attempt this he will indeed have to be careful in layout so as to keep distributed capacity down to the minimum and he will also find that a power tube is preferable as detector with a much higher plate voltage than usual, especially on wavelengths of 15 meters and upwards.

The 600-ohm decoupling resistances can easily be made if they are not obtainable in the States by purchasing wire which has a resistance of 1 ohm per foot run and winding 600 feet on small ebonite bobbins. As the writer has not much faith in commercial radio-frequency chokes, he advises the constructor to make his own for R4 by simply purchasing a 6-inch test tube from a pharmacy and about half an ounce of 36 gauge S.S.C. wire. Then wind on about 20 turns from the top and hold the beginning and end of this wiring by a small blob of sealing wax; then allow a space of $\frac{1}{4}$ " and wind about 8 turns with the same procedure; then another space and a winding of about 80 turns; then a space and about 65 turns and so on until there are about 180 turns all told. This radio-frequency choke can be held to the base-board by slipping it onto a champagne cork (if obtainable!!!!) held there by glue.

It will be seen that no audio amplifier is shown in the diagram or in the layout sketch, for the man who wants to use this receiver for telephone operation will find that, if a station is worth listening to, the volume will be quite sufficient without. On the other hand, with the

MR. SOMERSET'S RECEIVER, USING A COMBINATION OF ENGLISH AND AMERICAN COMPONENTS, IS PICTURED HERE

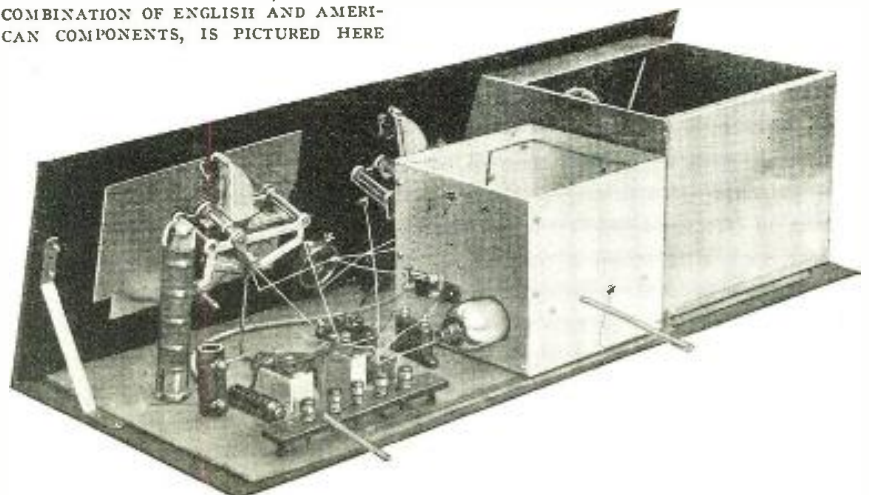

28-inch panel mentioned, there will be room available for the incorporation of an audio amplifier if it is desired to hear the 2LO announcer take breath on an electro-dynamic speaker! (5SW announcements are made from 2LO, of course.)

Operation

This will be found to be quite easy once the knack of following the r.f. tuning dial in the wake of the detector dial is mastered. The procedure is thus: set the detector tube oscillating by means of reaction (regeneration) control dial on C5; start at the bottom of C4's scale (detector tuning dial) and also with C2 at bottom of scale; now move C4 dial

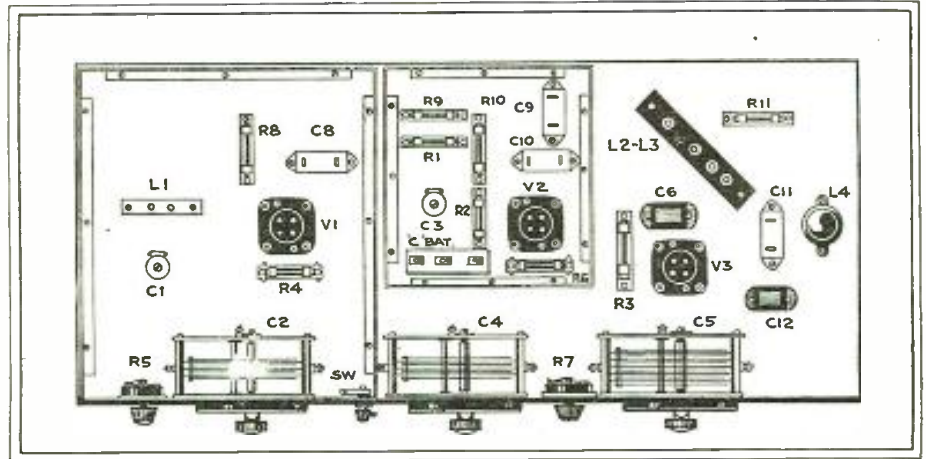

MR. SOMERSET SUGGESTS THE LAYOUT ABOVE FOR AN "ALL-AMERICAN" PRIZE-WINNER

megohm resistance across the transformer secondary may be tried as also another detector tube. However, when the constructor adds an audio stage I strongly recommend an output filter.

A Word of Warning

Do not lightly undertake the construction of this receiver, but give layout very careful consideration; keep grid and plate leads as short and as spaced apart as you possibly can; return by-pass condensers to the tube filament negative and *not* to a common negative line such as the shielding. If these precautions are taken (Continued on page 88)

THIS IS THE TWO-STAGE R.F. AND DETECTOR TUNER CIRCUIT EMPLOYED BY MR. SOMERSET



A FRONT OR PANEL VIEW OF THE RECEIVER SHOWN ON THE PREVIOUS PAGE.

slowly upwards and if no station is heard at, say, 20° on this dial, then move up C2 dial to 20° also and continue until a whistle is heard. When this happens, bring back the reaction control C5 until oscillation ceases and turn C2 one way or the other until maximum signal strength is obtained. Should any instability be observed it will probably be—if phones

only are used—r.f. currents getting past the radio-frequency choke; in this case another choke connected in series can be added with by-pass condenser to A—and an r.f. choke incorporated in the "B" supply line to one side of the phones. If when using an audio stage, threshold howl should be encountered, a .1 to .25

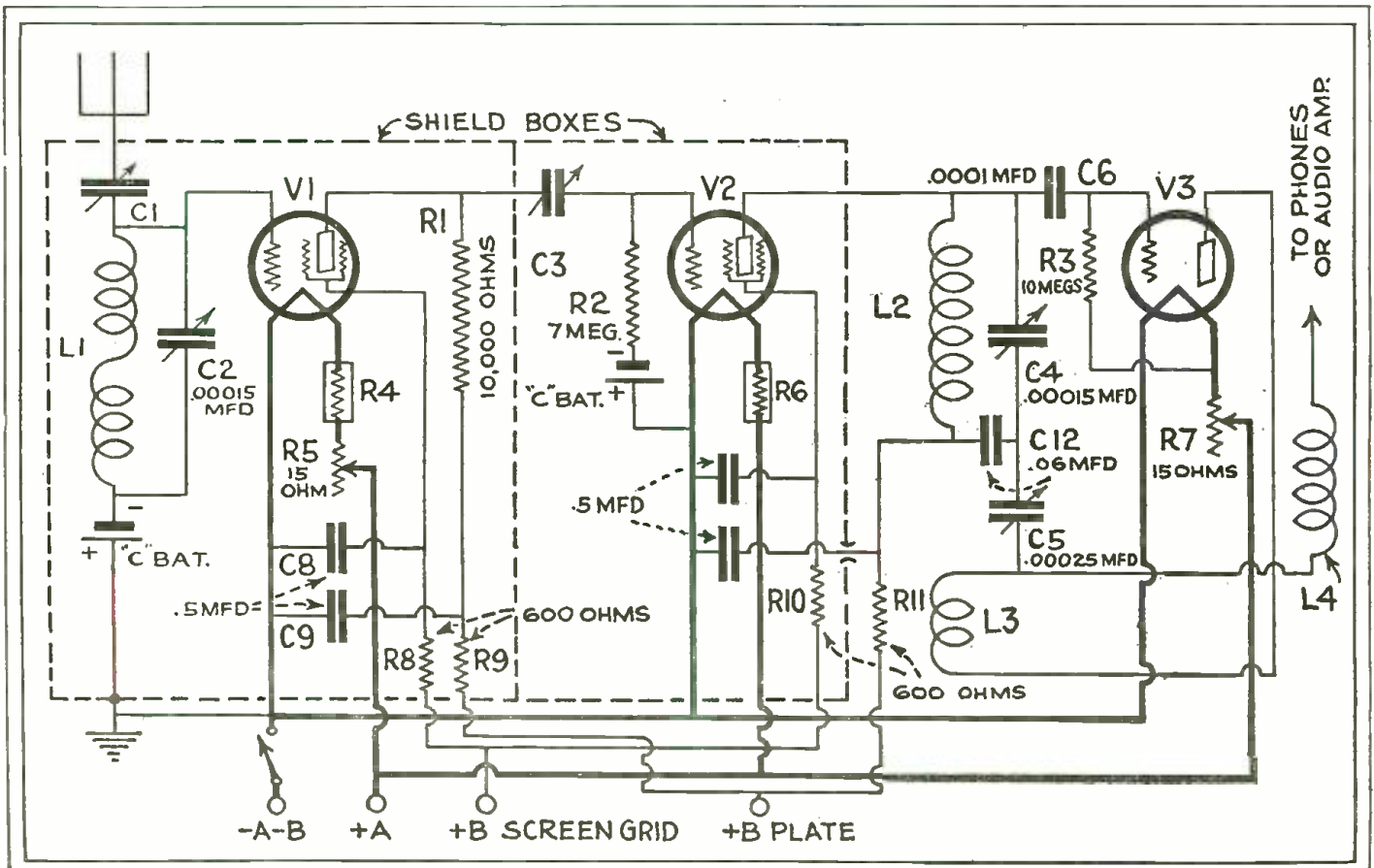

"Hello Little America— New York Calling"

By FRED E. MEINHOLTZ

IT is nearly 10,000 miles from New York to New Zealand. Little America, Antarctica, lies 2,400 miles to the southward. Commander Byrd in his book outlining his Antarctic plans writes: 'There is no place where one can get so far away from human life.' Yet, the longest radio circuit in the world—about 12,000 miles—connects the Antarctic Expedition of Commander Richard A. Byrd at Little America, on the Ross Ice Barrier in Antarctica, with the news room of the *New York Times* in The Times Annex at 229 West Forty-third Street.

"Every night, chiefly in the early morning hours, thousands of words of press as well as private messages dart through the air between Little America and Times Square. On one occasion, previous to the departure from the ice barrier of the S. S. City of New York and the Eleanor Bolling, Russell Owen, special correspondent of the *New York Times* and the *St. Louis Post Dispatch* with the expedition, filed over 8,500 words of press in a single night, and it all came through promptly and clearly.

"To illustrate the rapidity of communication and news handling between Little America and New York, let us suppose we are alongside Russell Owen and the time is now 3 P. M. and 10 P. M. in New York, the difference in time between

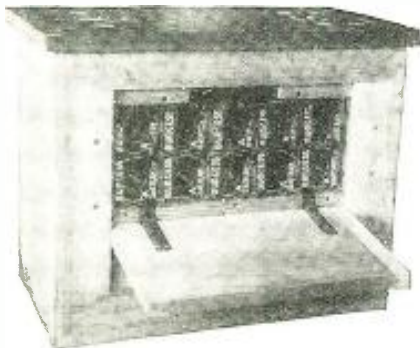

DRY CELLS ENCASED IN A SPECIAL BOX WITH BALSAM WOOL INSULATION FOR COLD PROTECTION

the two places being seven hours. The day in the Antarctic has not drawn to a close and the day's events have not yet been chronicled by Russell Owen. Radio contact is established and we hear the operator ask Owen for his story. Owen interrupts the conversation, jumps to his portable typewriter, writes a paragraph and hands it over for radio transmission. A few moments later this first paragraph has been received by the short wave set in the *Times* radio room, and has been



READERS of RADIO NEWS will remember Mr. Meinholtz as the author of the article appearing in our April issue wherein he described the constructional details for the New York Times short-wave receiver especially designed for maintaining communication between New York and the Byrd Expedition's base at Little America on the Ross Ice Barrier in the Antarctic Ocean.

Mr. Meinholtz's rather matter-of-fact recitation of the ease with which communication is maintained between his office and Commander Byrd is due undoubtedly to the fact that he considers it all in the day's work, but readers of RADIO NEWS will not fail to recognize that here is something taking place right about them that savors of romance and the making of radio history.

Radio and aviation are bringing "the other end of the world" right next door.

placed upon the desk of F. T. Birchall, the managing editor, on the same floor not more than 100 feet distant.

"To the office boy who delivered the copy, the managing editor will say:

"Tell our radio operator if Owen hasn't given the length of his story have him do so immediately so that space can be reserved for it in the paper."

"In a few more moments a message from Owen will be placed upon the managing editor's desk:

"Estimate about two thousand words."

"All this without interruption to radio transmission of the news story—paragraph by paragraph as Owen types it, we hear the radio operator flashing the story, and unless serious fading or static interrupts transmission, the entire story is in the hands of the managing editor before Owen puts away his typewriter and resumes the conversation.

Connection Is Direct

"All dispatches with the unfamiliar date line Little America, Antarctica, come directly into the *Times* office without manual relay. Owing to electrical interference, known as man-made static or induction, it is often necessary for us to 'pipe' the signals into the *Times* from a location free from this radio bugbear. For this purpose we have installed a remote receiving station in the country near North Woodside, L. I. When necessary, an operator at that location will

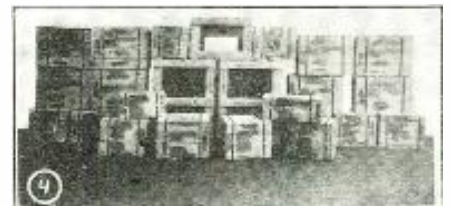

A PILE OF BOXED BATTERIES TAKEN ALONG BY THE BYRD ANTARCTIC EXPEDITION

tune the receiver to the proper frequency, throw a switch and the signals are automatically carried over a leased telephone wire into the waiting ears of the radio operator at the *New York Times*.

"Immediately upon their receipt in the *Times* office the Byrd dispatches are distributed by cable, telegraph and wireless from the syndicate room on the same floor as the radio room, for simultaneous publication in newspapers throughout the world. They are published in more than thirty-five newspapers in the United States, several in Canada, several in Mexico and other Latin-American coun-

tries, in London, Paris and a dozen European cities and in Japan and Australia.

Although the main exploration and scientific work of the expedition will not commence until the Antarctic Summer, which is our Winter, as the seasons are reversed, nevertheless, we have already furnished our readers with upward of 150,000 words of press dispatches and have transmitted and received over 5,000 personal messages. These messages are handled gratis by the *Times* in order to keep members in close touch with the home folks, thus effectively lessening the sacrifice that mothers, wives and sweethearts have made in making it possible for them to join the expedition. If by the exchange of such messages we can help to break up the isolation of the Ant-

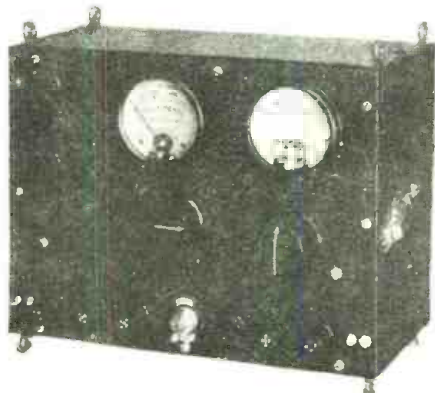

A SPECIALLY CONSTRUCTED AIRPLANE AND SLEDGE SHORT-WAVE TRANSMITTER

arctic we will feel amply repaid for the long hours of toil throughout the early morning hours.

Keeping Up Morale

"On April 19 the Antarctic sun dropped below the horizon and the long Antarctic night is now at hand. Explorer after explorer has written of the difficulty in keeping up the morale of his expedition, especially during the period of darkness.

A SUPER-HETERODYNE TUNER DEVELOPED BY THE WESTINGHOUSE LABORATORIES AND USED IN THE RADIO ROOM OF THE S. S. CITY OF NEW YORK

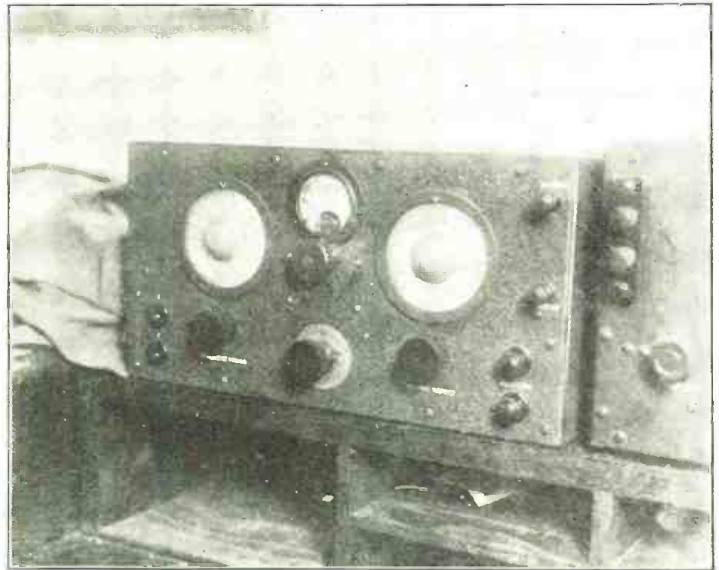

Commander Byrd in his recent book, 'Skyward,' writes of the same thing. Under the heading of 'The Last Challenge' on page 306 he writes:

"On long expeditions in cold and unresponsive countries such as the Antarctic, untoward characteristics appear in the individual that we never dreamed of in civilization."

"Again, on page 301 of his book 'Skyward,' Commander Byrd writes:

"A Winter in Antarctica is not as easy for the personnel as in the North. Most of those with Amundsen were old-timers; Scott also had many with him; yet both parties felt the deathlike isolation of the region about them. North Polar expeditions have always tempered their loneliness by hunting bears, caribous and muskoxen as well as by intercourse with friendly native tribes. There is none of this life down there."

"The communication system has been a phenomenal success compared to what was expected. This is the first time that

A SHORT-WAVE AIRPLANE AND SLEDGE RECEIVER, COMPANION TO THE TRANSMITTER OPPOSITE

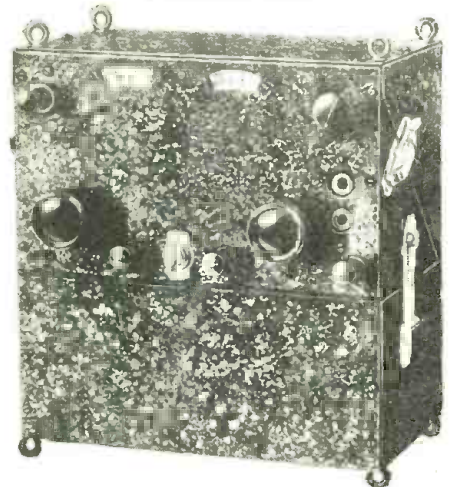

anything of the sort has been attempted in the Antarctic, and although it was hoped that fairly reliable communication could be maintained with the outside world, no one connected with the expedition had any idea that the results would be as good as they have been.

"At times the transmission has been in every way as good as over an ordinary telegraph wire. Conditions vary from day to day, however, and at times great difficulties have been encountered getting the news through. From the time the expedition left New York, seven months ago, however, not a single night of communication has been missed. On three or four nights we have been unable to receive long press dispatches, but have always been able to exchange messages.

Explanation of Trouble

"What troubles there have been, it is thought, have the following explanation: In high frequency radio, certain frequencies work well in the daytime, others at night. A peculiar condition exists in



THE RECEIVING-TRANSMITTING ROOM AT THE NEW YORK TIMES. MR. MEINHOLTZ IS AT THE LEFT. NOTE IN THE BACKGROUND THE NEW YORK TIMES RECEIVER, DESCRIBED IN THE APRIL RADIO NEWS

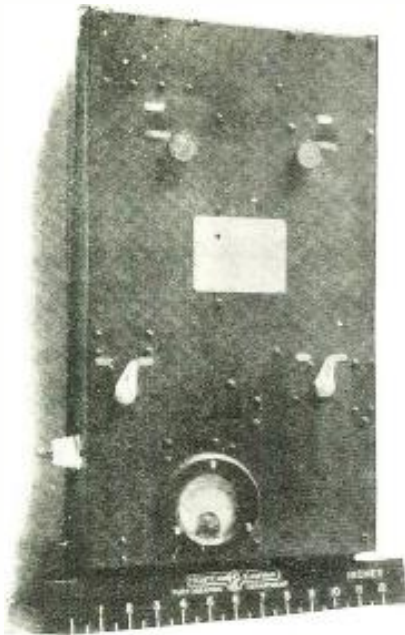

THIS SHOWS THE TYPE OF DUPLEX LONG WAVE-SHORT WAVE TRANSMITTER USED ON THE SHIPS AND BASE STATION OF THE BYRD ANTARCTIC EXPEDITION

communication between New York and the South Pole region, in that every signal must pass through both a dark and a day belt before it reaches its destination. With the Antarctic night now at hand it will be possible to work at certain periods of the night wherein darkness covers the entire path.

The *Times* not only receives but also sends 'press dispatches' daily to the expedition. At 1 o'clock every morning a complete summary of the news of the preceding day, consisting of 1,500 words or more, is transmitted to the Antarctic so that Commander Byrd and his crew may publish their own newspaper and keep abreast of what is happening in the civilized world.

The digest of the day's events usually consists of from twenty to thirty concisely written items—four or five on in-

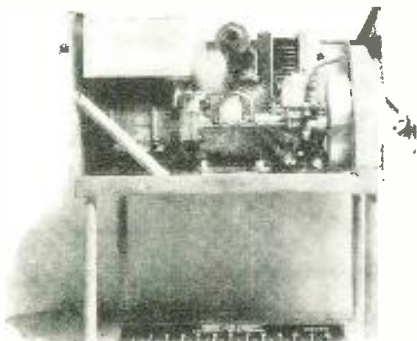

A PORTABLE ONE-CYLINDER GAS ENGINE OF THE TYPE SHOWN ABOVE IS CARRIED BY THE PLANES AND SLEDGE PARTIES, SO THAT IN CASE OF A FORCED LANDING OR UNEXPECTED STOP SOME MEANS OF GENERATING POWER FOR THE TRANSMITTER WILL BE AT HAND

ternational affairs, four or five from New York, four or five about sporting events, etc. All aviation and a good deal of shipping news is transmitted. Queries about certain events are frequently re-

ceived. Commander Byrd was especially interested in Captain Sir Hubert Wilkins's expedition to Graham Land and Captain Mawson's proposed expedition to Wilkes Land to the east of Byrd's camp and requested that all information about them be furnished him. Other members of the expedition have been interested in different types of news, and several have asked for all the information available on the action of the stock market affecting certain stocks. The speculative fever has even touched the men in the Antarctic and stock brokers have received orders from Little America to buy or sell at the market.

Listening-in on Byrd

"The radio operators in the *Times* office have been especially interested in listening in to radio communication between Commander Byrd at Little America and dog-team caravans and airplanes in the Antarctic air. We have frequently by so listening in picked up sufficient information to keep us informed of the movements of the various units at times

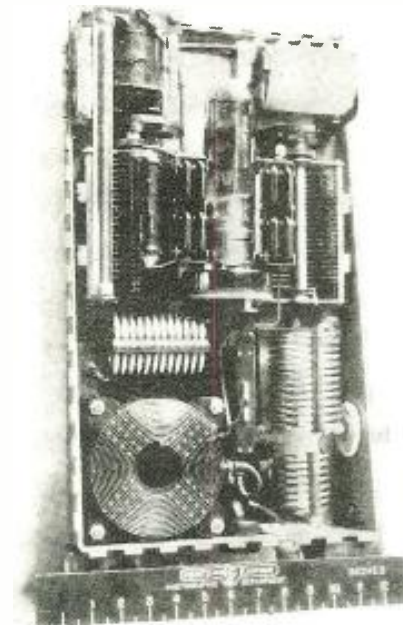

A BEHIND-THE-PANEL VIEW OF THE DUPLEX TRANSMITTER. SOME IDEA OF ITS COMPACT SIZE MAY BE GAINED FROM THE RULER SHOWN AT THE BOTTOM OF THE ILLUSTRATION

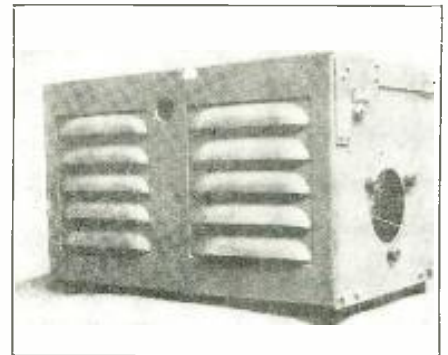

THE SHEET METAL VENTILATED CASING FOR THE ONE-CYLINDER ENGINE

when the radio at Little America was too busy to give us the information. We recently were able to exchange messages with an airplane 3,000 feet above Little America, thereby establishing a long-distance plane-to-shore radio record which will stand for all time. Oddly enough, by doing this we broke our own record, for we held the previous record when we received the S O S signals of the airplane *Dallas Spirit* during the Dole flights as she tailspinned into the Pacific 500 miles west of San Francisco.

"Another rather unique record was recently made when for the first time a

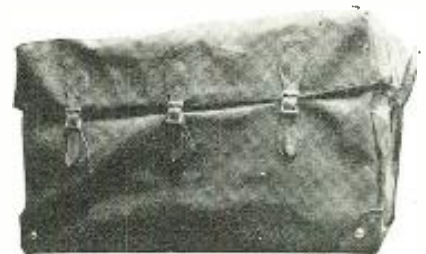

A WATERPROOF COVERING ENCLOSES THE "ONE LUNG" ENGINE

local telephone call in New York was made by way of the Antarctic. When the ships of the Byrd Expedition were picking their way through the ice cakes at the entrance to Ross Sea, I was at my home in Bellaire, L. I., listening to a press dispatch being sent by one of Commander Byrd's operators. I do this frequently in order to get the news hot off the Antarctic ice. Suddenly I was startled to

(Continued on page 82)

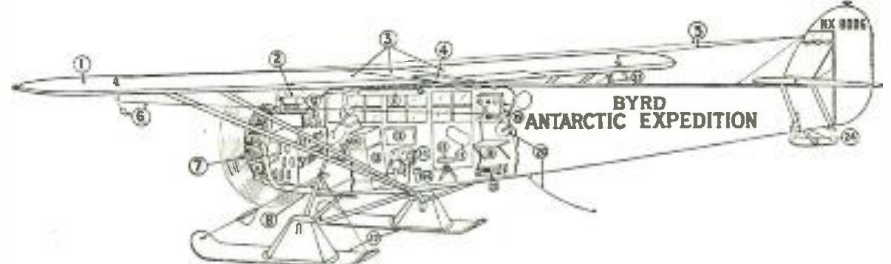

- | | | |
|---------------------------------------|--------------------------------------|---|
| 1. Folding wings | tor. air speed indicator, altimeter. | 17. Window for photographing ob- |
| 2. Wind driven generator | aperindic compass, tachometer. | liquers |
| 3. 260 gallons gasoline in wings | clock | 18. Table |
| 4. Window for sextant readings | 10. Automatic fire extinguisher | 19. Radio sending and receiving set |
| 5. Radio antenna for transmitting | 11. Gun rack | 20. Drop radio antenna and reel |
| 6. Radio antenna and wind cone | 12. Map case | 21. Gasoline generator for radio trans- |
| 7. 400 H.P. "Wasp" engine | 13. 75 gallon gas tank | mitter |
| 8. Cabin heater | 14. Fairchild mapping camera | 22. Ski- |
| 9. Earth induction compass, turn and | 15. Stool | 23. Compass wind driven generator |
| bank indicator, rate of climb indica- | 16. View finder | 24. Tail ski |

Plane also equipped with dual control, landing lights, flying lights, ice warning thermometer and flares

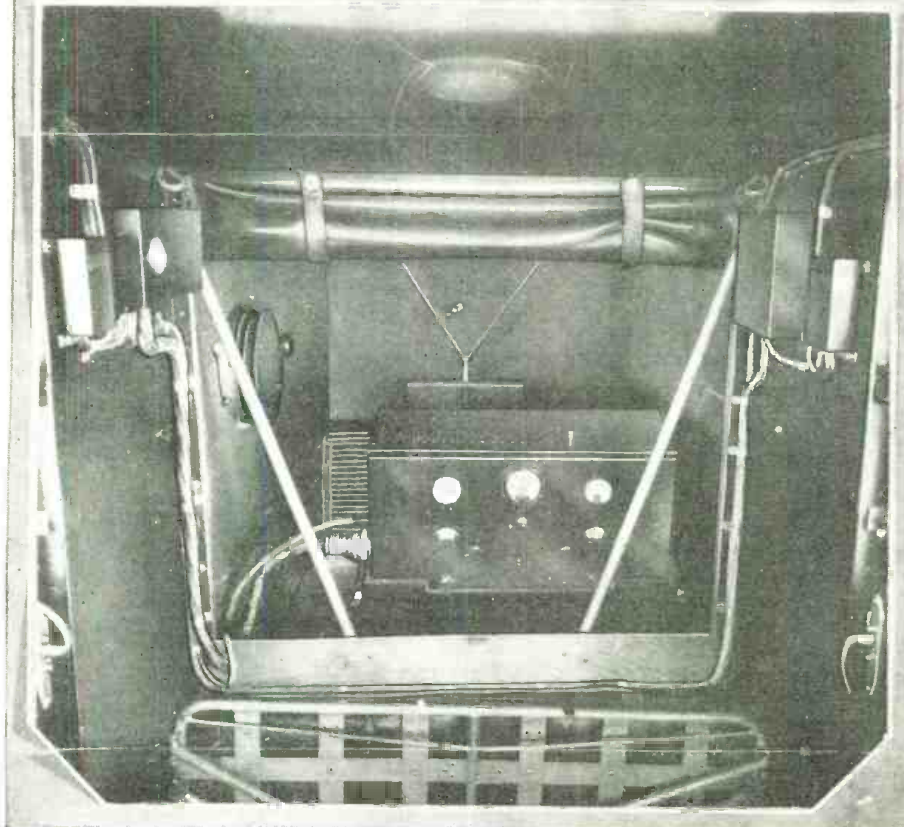
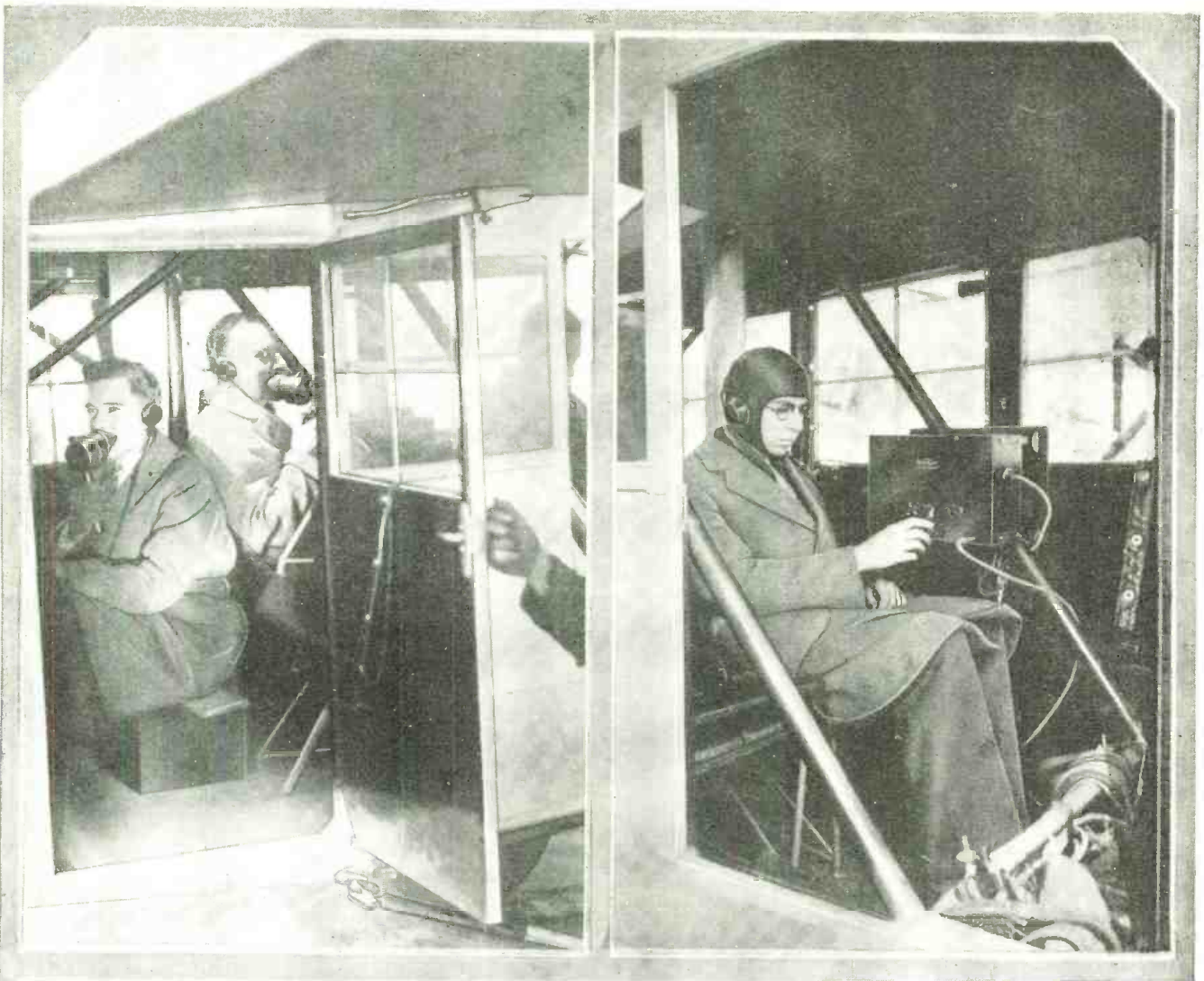

Reporting From the Air

Two-way radio telephone communication between an airplane and a ground station was accomplished recently by engineers of the New Jersey Bell Telephone Company. Dual microphones in the cabin of the plane for the use of observer and pilot are shown in the upper left. Note the stream-line antenna pole situated behind the head of the receiving operator. Above is shown the receiving equipment while at the left is illustrated the transmitter.

The occasion for this dual communication was the dedication of a tablet in the telephone building auditorium to honor the late Theodore N. Vail.

A banquet held simultaneously in six of New Jersey's chief cities celebrated the event and conversation between the plane and the diners was an important item on the program.

How to Build the Taylor Band Isolator

By GORDON TAYLOR

IN LAST month's article a general description of the theory of the Band Isolator receiver was given, together with the records of tests made to determine the ability of this receiver to step out and pull in far distant stations right through the early evening hours with local New York stations going full blast. During these tests reception was obtained on all but three of the channels then in use, which means that, starting at the lower end of the dials and tuning on up throughout the entire broadcast band, stations were heard at 10 kilocycle intervals, except at the channels occupied by the three stations that could not be brought in, and on two channels on which stations were not operating. All of this was accomplished from a typical New York City location and before 11:30 P. M. Twenty-five states were represented in the resulting log, including such far distant states as California, Colorado, Florida, Texas and Utah.

This record speaks volumes for both the sensitivity and the selectivity of the Band Isolator receiver. All but the most powerful local stations were readily cut out to bring in DX stations in adjacent channels and even the most powerful local did not interfere beyond one channel either side of its own frequency.

All of this is accomplished with but five tubes (excluding the audio end, which is not included in the receiver proper). No r.f. amplification is used ahead of the first detector and only two intermediate frequency stages are used. The extreme amplification obtained is the result, first, of using screen-grid tubes in a circuit that takes the fullest advantage of their tremendous amplifying powers. Secondly, the intermediate amplifier stages are individually tuned with midget condensers to permit bringing them to exact resonance with one another and in this way eliminating the broad tuning and comparatively poor amplification obtained with some super-heterodyne receivers.

In addition to the selectivity and sensitivity (which were more fully explained in last month's article) is the fact that this receiver is unlike other super-heterodynes in operation. It tunes like any tuned r.f. receiver, rather than a super-heterodyne. The tuning is sharp, but stations always come in at the same dial settings, without whistles or squeals, and without repeat points on the oscillator dial.

A detailed description of the various features of the receiver is best given by

IN this, the final installment of his articles on the Band Isolator Tuner, Mr. Taylor describes the steps to be followed in assembling, wiring, testing and operating his receiver.

For those of our readers who desire to build an up-to-the-minute super-heterodyne, Mr. Taylor's receiver will make an especial appeal.

Only parts of highest grade have been employed in its construction, and if the builder desires to obtain reception similar to that outlined by Mr. Taylor in last month's RADIO NEWS it is recommended that he adhere strictly to the use of those parts listed.

following through the schematic diagram of the circuit. The input, or first detector circuit, consists of a specially designed three-circuit auto-coupling transformer with center-tapped primary, secondary and feed-back coils. A standard variable condenser is employed for tuning the secondary and a midget condenser to control feed-back where it may be required in the reception of very distant or weak stations. The auto-couple principle is obtained by mounting the transformer directly on the rear of the tuning condenser so that its primary is moved in and out of the secondary by means of a cam arrangement as the condenser plates are meshed and unmeshed. Thus the coupling is loose for low-wave stations and close for the high-wave stations.

The oscillator pick-up coil, which is part of the oscillator transformer, T2, is connected in series with detector grid return, at the filament end. It is not desirable to have the pick-up coil included directly in the tuned circuit of the detector, so the tuning condenser is shunted across only the secondary coil of T1. This means that the rotor plates of the tuning condenser are not at ground potential, being separated from ground (A—) by the oscillator pick-up coil. Inasmuch as this condenser is mounted directly on the front the shield, SH1, this shield cannot be at ground potential either, otherwise the pick-up coil would be short-

circuited and no signals would be heard. It may seem a little unusual to shield a circuit without directly grounding the shield but it has absolutely no harmful effects in this case.

The oscillator circuit is not shielded because experiment showed that nothing was to be gained by shielding here. The transformer, T2, like all of the other transformers used in this receiver, was especially designed. Inasmuch as an unusually high intermediate frequency is employed in the Band Isolator intermediate amplifier, the oscillator must necessarily have a correspondingly high-frequency range; which in turn involves the use of fewer turns than on the ordinary oscillator coil. Moreover, a pick-up coil of unusual design is included in this transformer, with the result that adjustment of the oscillator tuning condenser has absolutely no effect on the tuning of the first detector circuit and the two tuning controls are therefore entirely independent of one another. The extra variable condenser indicated at C7 is a balancing or equalizing condenser employed to bring the oscillator tuning dial settings into track with those of the other tuning control. It need be adjusted only once and then left in that position.

In the input circuit of the first intermediate stage is a tuned transformer consisting of primary and secondary. The tapped primary is, of course, connected in the plate circuit of the first detector, with the choke coil, RFC1, between it and the "B" supply. No by-pass condenser is used here. If it were, no regeneration would be obtained in the first detector circuit, even with the plates of the midget condenser, C3, entirely meshed. Omission of the choke has the same result.

The secondary of the input transformer is tuned by means of three condensers, each of which serves a definite purpose. First there is a fixed condenser which provides the main tuning capacity. Unfortunately, even the best fixed condensers of a given capacity rating are not exactly alike in capacity. They are manufactured with a tolerance of 10% plus or minus, which is quite close enough for the purposes for which fixed condensers are ordinarily used. But for their use in this circuit, where they are employed for tuning purposes, greater accuracy of capacity is required. Moreover, it is desirable to have room for a small frequency variation in the tuning of the intermediate circuits, to permit obtaining exact resonance. Third, the preferred frequency

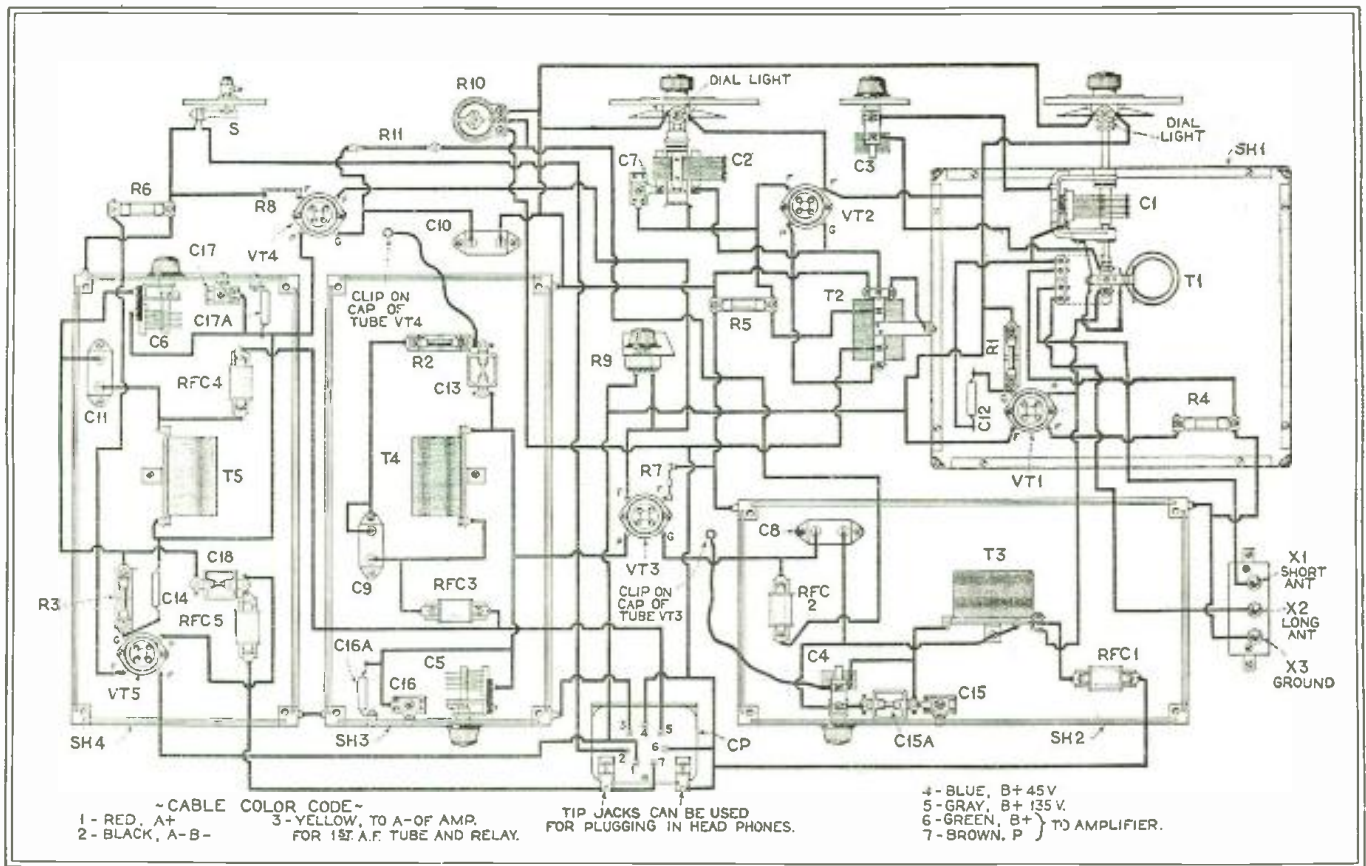

at which to operate this intermediate amplifier requires the use of approximately 200 micro-microfarads capacity. The nearest standard fixed condenser to this is rated at 100 mmfd.

To meet all these conditions, the fixed condenser is shunted by an equalizer condenser and a midget variable condenser. The equalizing condenser is adjusted so that, with the rotor plates of the midget condenser all out, the circuit is brought to resonance with the other two circuits. Thus the tuning characteristics of the three tuned circuits are equalized and each has the 50 mmfd. variable capacity of the midget condensers to provide room for variation of the intermediate frequency if desired.

Another purpose served by the midget condensers, which are mounted with their knobs on the outsides of the three shields, is to permit variation of the circuit capacity to make up for slight changes which take place when the shield covers are put in place. If these midgets were not used the circuits would have to be adjusted to resonance with the shield covers off; only to be thrown out again when the covers were put in place.

The second tuned intermediate circuit, which is located inside shield SH3, is tuned in the same way as the input circuit, although in this case the tuned coil is in the plate circuit of VT3 instead of in the grid circuit. This means that this coil is at plate potential. To permit mounting the three tuning condensers on the shield walls the fixed block condenser, C9, is included in the circuit so as to isolate one side of each tuning condenser from the high voltage supply. This blocking condenser serves at the same time as

IN THIS PARTS-LAYOUT DIAGRAM OF THE BAND ISOLATOR RECEIVER, NOTE THAT THE INDIVIDUAL PARTS ARE NOT DRAWN TO SCALE. EACH OF THE PARTS, HOWEVER, IS CENTERED EXACTLY IN ITS PROPER RELATIVE POSITION. IN THIS WAY, IT IS POSSIBLE TO SHOW ALL THE WIRING, WITHOUT THE CONFUSION THAT WOULD RESULT FROM PICTURING ALL THE COMPONENT PARTS FULL SCALE SIZE

a by-pass condenser across the 135-volt plate supply.

The second detector circuit is similar to that of the second intermediate stage, except that its output is carried directly to the cable plug through the choke, RFC5, after by-passing through C18. The second detector stage, like the two preceding stages, is inclosed with its own shield. The three shields, SH2, SH3, and SH4, are all grounded to A—.

In addition to employing chokes in the two detector plate leads, chokes are also included in the plate supply leads of the two screen-grid tubes, as well as in the screen-grid lead of VT3. In the case of VT4, a resistor is used in the screen-grid lead. A choke might have been used instead of this resistor but seemed to have no advantage, so the resistor was employed because of its smaller size.

There will probably be some surprise when it is stated that this receiver was designed to use CX-299 tubes for first detector and oscillator. The reason for this is that these small tubes are just as good as larger tubes in these positions and have the advantages of smoother control of regeneration, in the case of the first detector, and lower filament current consumption. 301A tubes may be employed in these two positions if desired, but results will be somewhat more satisfactory with the small tubes.

The filament current for VT1, VT2 and VT5 is controlled through the the use of

individual amperites. In the case of the screen-grid tubes a fixed resistor is inserted in the negative side of each filament circuit to provide the required "C" bias voltage. In the positive side of the circuit a rheostat is incorporated to permit exact adjustment of the filament voltage.

A somewhat unusual feature is found in the connections of the filament switch, S. This switch not only controls the filaments of the five tubes and the two dial lights in the receiver, but may also be made to control the filaments of an external audio amplifier by connecting the A— terminal of the latter to the lead provided in the cable plug of the receiver, instead of to the "A" battery direct. If a relay is used to provide automatic control of a trickle charger and the power pack, it also may be operated from this same switch by this means.

The volume control employed, R10, is a 500,000-ohm potentiometer. This is connected directly across the 45-volt supply but its resistance is so high that the current drain is only a fraction of one milliamperere. Moreover, the circuit is broken when the receiver is turned off so in cases where batteries are used for the "B" supply there need be no worry about this drain.

There are just two more points for consideration before starting the construction. For the second detector a 300A tube is recommended for maximum sensitivity. Second, the cable plug

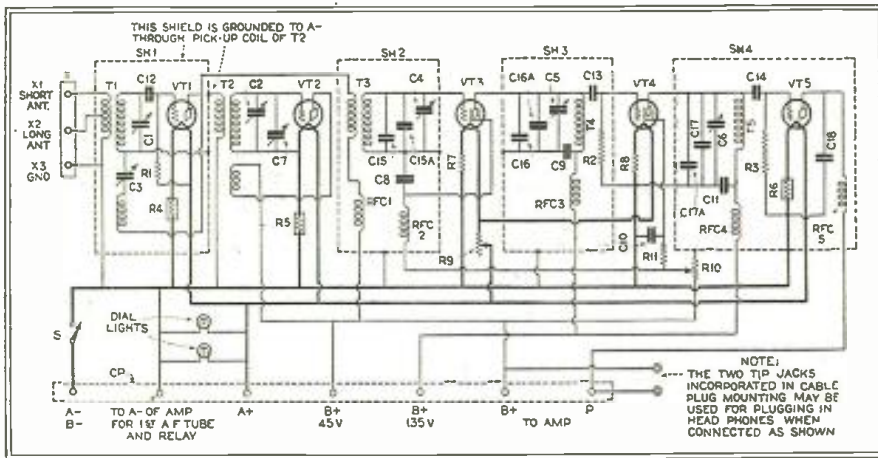

THIS CIRCUIT DIAGRAM OF THE BAND ISOLATOR RECEIVER EMBODIES A CORRECTION WHICH SHOULD BE NOTED. THE ORIGINAL DIAGRAM (JUNE RADIO NEWS, PAGE 1107) FAILED TO INCLUDE CONDENSER C17A, IN SHIELD CAN SH4.

BELOW, LOOKING DOWN ON THE COMPLETED BAND ISOLATOR RECEIVER, WITH SHIELD COVERS REMOVED TO SHOW THE VARIOUS PARTS

specified contains two phone tip jacks. When wired as shown in the diagram, headphones may be plugged in. This is a convenience to DX fans who prefer headphones when "fishing" for DX.

Most of the details of the assembly of the Band Isolator Receiver are made clear by the accompanying illustrations. However, there are some points which require explanation, and there are some suggestions which are in order.

All of the instruments which are to be mounted on the baseboard should be laid out in place, including the shield bottoms and the instruments that are to be mounted thereon. Then, with a pencil or scribe, the locations of all mounting holes should be marked on the base and shield bottoms. During the assembly the shield bottoms will be attached to the baseboard only by the screws used in mounting the instruments; to pass which, holes should be drilled through the aluminum bottoms. Directly under the corner holes of the bottoms of shields SH2, SH3 and SH4 half-inch holes should be drilled through the baseboard so that after the receiver is completed it will always be possible to tighten up the corner screws from underneath. Also, these half-inch cutaways permit the insertion of soldering lugs under the heads of these screws without raising the shield bottoms off the baseboard. A 3/8-inch hole should be drilled through the bottom of SH1 and baseboard, directly under the hole in square bar at bottom of primary coil carriage. This will permit special coupling adjustment, as described later.

All of the holes required in the shield bottoms to permit the passage of the mounting screws of the various instruments should be drilled, and any burrs which result should be filed off before attacking to baseboard. Otherwise, burrs between shield bottoms and baseboard will cause the shields to buckle.

All of the wires which are brought in or out of the shields SH2, SH3 and SH4 are provided for by filing three-cornered slots in the bottom edge of the sides or ends instead of drilling holes for their passage. This simplifies the wiring, because there is no necessity for threading the leads through holes, but more important, the shield sides and ends need not be placed in position until the wiring has been completed.

This cannot be done so readily in the

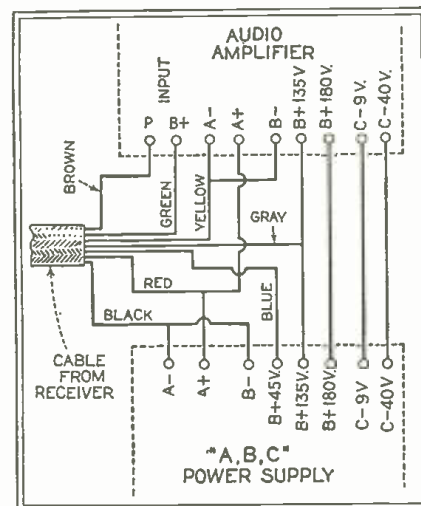
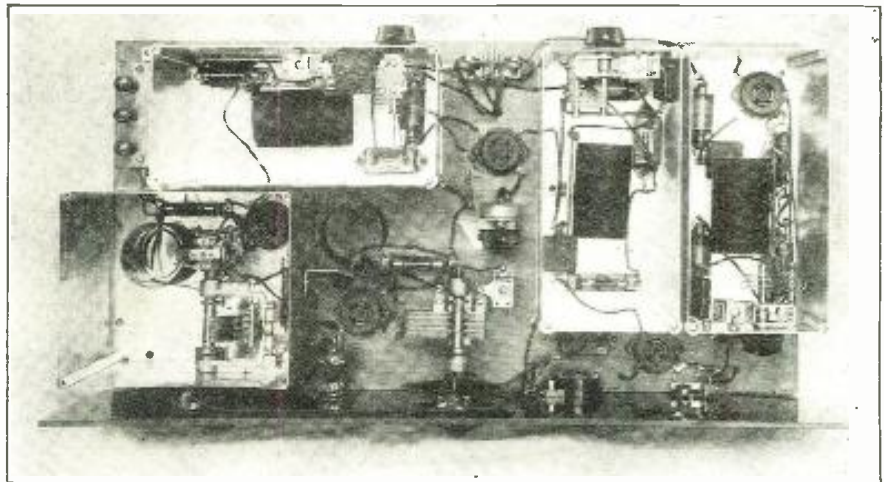

CONNECTIONS FOR THE CABLE FROM THE TUNING UNIT TO AUDIO AMPLIFIER AND POWER UNIT

case of SH1, so there the usual practice of drilling holes to accommodate the leads is followed. The other exception is in the case of the leads going to the top terminals of the screen-grid tubes. They are provided for by filing slots in the top edges of the end plates of the corresponding shields.

The instruments to be mounted on the shield bottoms are as follows:

- SH1—BT1, R1, R4.
- SH2—RFC1, RFC2, T3 and C8.
- SH3—RFC3, C9, T4 and R2.

SH4—RFC5, VT5, RFC4, C11, R3 and T5.

After "spotting" and drilling the mounting holes for these, the assembly may proceed. First attach the four corner posts to each of the bottoms of shields SH2, SH3 and SH4, placing a soldering lug under the head of each screw used for this purpose. Then place these aluminum plates in position on the baseboard and mount the instruments listed above, using wood screws for this purpose. The bottom of SH1 may also be put in position and in instruments mounted in position. In this case no corner posts are used.

The three tuning condensers in SH2, SH3 and SH4 are mounted on the side or ends of the shields, as close to the top edges as possible but leaving ample clearance for the shield covers. Inasmuch as one side of each of the condensers in these shields is at ground potential, it is convenient to mount them solidly on the shield walls in this manner, except for the fixed condenser in SH2, which is supported between the terminals of the other two condensers. The balance of the assembly work is sufficiently clear so that no further explanation is required. It may be worth while to note that if a suitable mounting bracket for the rheostat, R9, is not available, one of the metal templates which accompanies the Hammarlund tuning condensers may be bent to serve admirably.

(Continued on page 89)

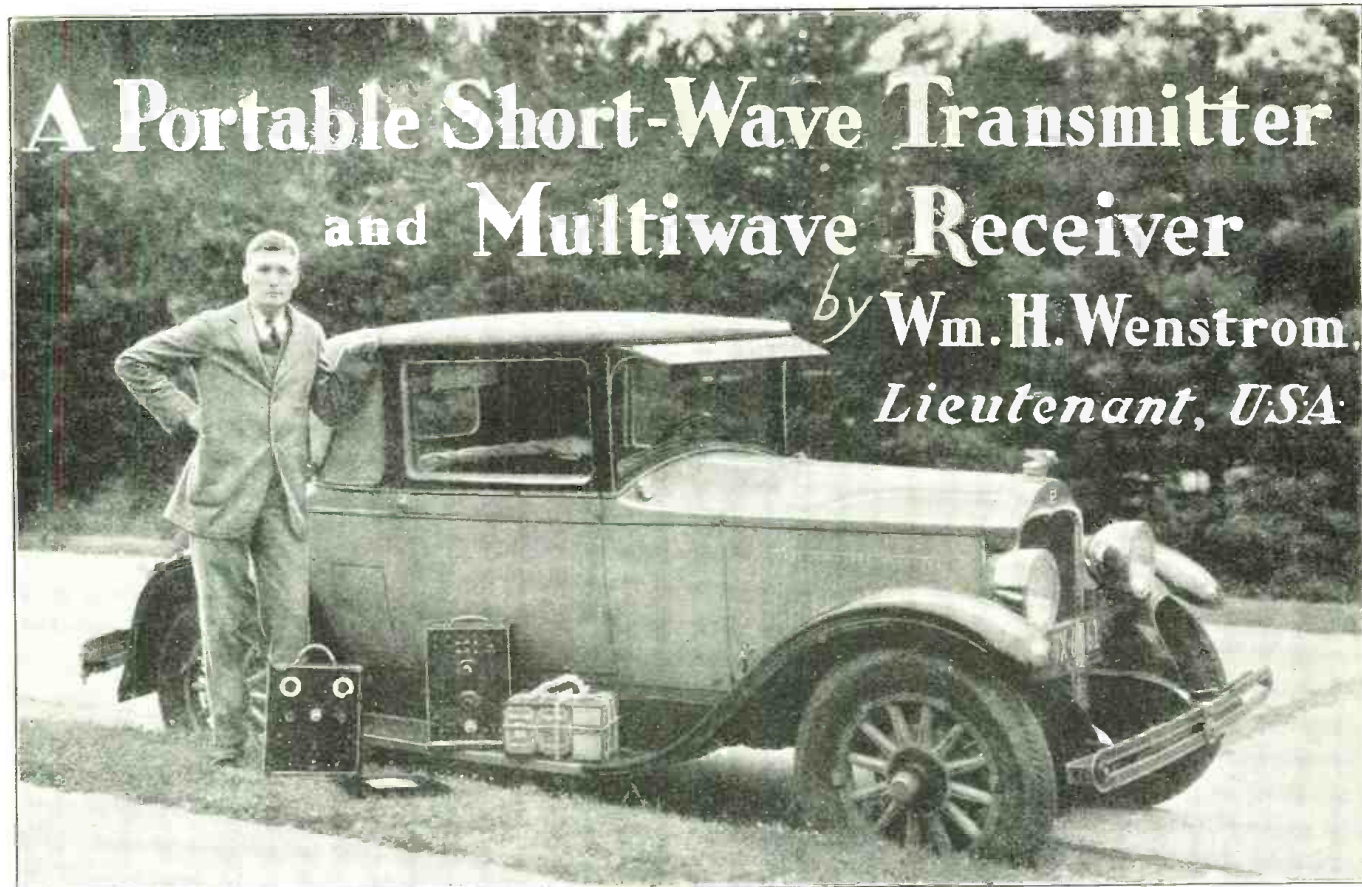

A Portable Short-Wave Transmitter and Multiwave Receiver

by Wm. H. Wenstrom,
Lieutenant, U.S.A.

THERE are finite limits to all terrestrial DX. The antipodes are only twelve thousand miles away; in time London palls and even Australia goes stale. Our morale may rise on hearing the signals of a transatlantic airplane, but it really takes a jump when we hear our friend say from the far shore of a mile-wide lake: "We reached the cove before the storm hit—everybody safe."

For such occasions, and for more prosaic work as well, this low-power portable transmitter is designed. Its reliable daylight range is two miles with phone and twenty miles with code.

Of course, "communication" is a dual affair and depends as much on the receiver as on the transmitter. The description of a suitable receiver follows this article. The transmitter's dimensions are slightly different from those of the receiver, but in general it is designed as a companion unit.

As in the receiver, one-fourth inch bakelite serves as the panel and also as the framework of the set. Though this construction is not the most compact, it has advantages. It is very easy to assemble, strong and rigid, and accessible—when the panel is tipped forward all parts are instantly exposed to view.

Circuit Details

The transmitter circuit is a series-fed Colpitts, often called the Hoffman split Colpitts. It is shown in Fig 1. All standard oscillator circuits are much alike in efficiency, despite the arguments of their advocates; but the Colpitts has two advantages which make it ideal for

portable use: first, one variable condenser absolutely controls the oscillator frequency over a wide range (see calibration curve, Fig. 6) with no guess work inductance clips, no flopping out of oscillation, no plate current acrobatics; second, two large condensers directly across the tube elements keep the emitted wave exceptionally steady—practically as steady as that of an oscillator-amplifier circuit. In addition, the series feed brings the plate supply and grid bias leads into the radio frequency circuit at points of low potential. A minor disadvantage of this circuit—no control of grid feedback, as evidenced by heavy plate currents—is nullified by using a high value of grid leak (around 10,000 ohms).

The Power Supply

After the circuit itself, the matter of power supply demands consideration. An "A" battery of dry cells may be essential

when the outfit is packed on horses or mules, but for most uses a small storage battery, which will deliver a more constant voltage, is preferable. The plate battery, however is a different matter. Dry "B" batteries are bulky enough; wet ones are out of the question. No dynamotor is made small enough for a set like this. The only trouble with the dry "B" battery is its bulk and weight; in other ways it is ideal. For any sort of economy we must use heavy-duty units, of which two or three, even though equipped with a handle, are not too easy to carry. The plate battery, then, is limited to either 90 or 135 volts—preferably 135.

We now have to find a tube that will produce some semblance of antenna amperes on the meager plate voltage of 135. It is a good deal like asking a confirmed drunkard to get hilarious at a prohibition picnic. Several UX-201As in parallel would take up too much space, but it fortunately happens that the UX-171 is

OSCILLATOR OUTPUT AND COMPARATIVE EFFICIENCY					
On 85 meters, antenna and counterpoise terminals shorted through r. f. ammeter					
	E_p	I_p	$E I_p$	R.F.	Efficiency Index*
UX-171A	96	21	2.19	.75	.34
	142	40	5.68	1.30	.23
UX-112A	96	16	1.53	.60	.39
	142	28	3.98	1.00	.25
UX-201A	96	11	1.06	.45	.42
	142	16	2.37	.60	.26
WE-216A	96	12	1.15	.50	.44
	240	42	10.01	1.40	.14

*THE EFFICIENCY INDEX IS OF VERY DOUBTFUL VALUE, AS IT IS ENTIRELY COMPARATIVE, AND PROBABLY INACCURATE.

THE PURPOSE OF THIS TEST WAS TO GET AN IDEA OF THE PERFORMANCE OF VARIOUS TUBES IN THE PORTABLE TRANSMITTER. THE UX-171A, OR 171, WAS CHOSEN BECAUSE OF ITS HIGH R.F. OUTPUT WITH A LOW VOLTAGE PLATE BATTERY.

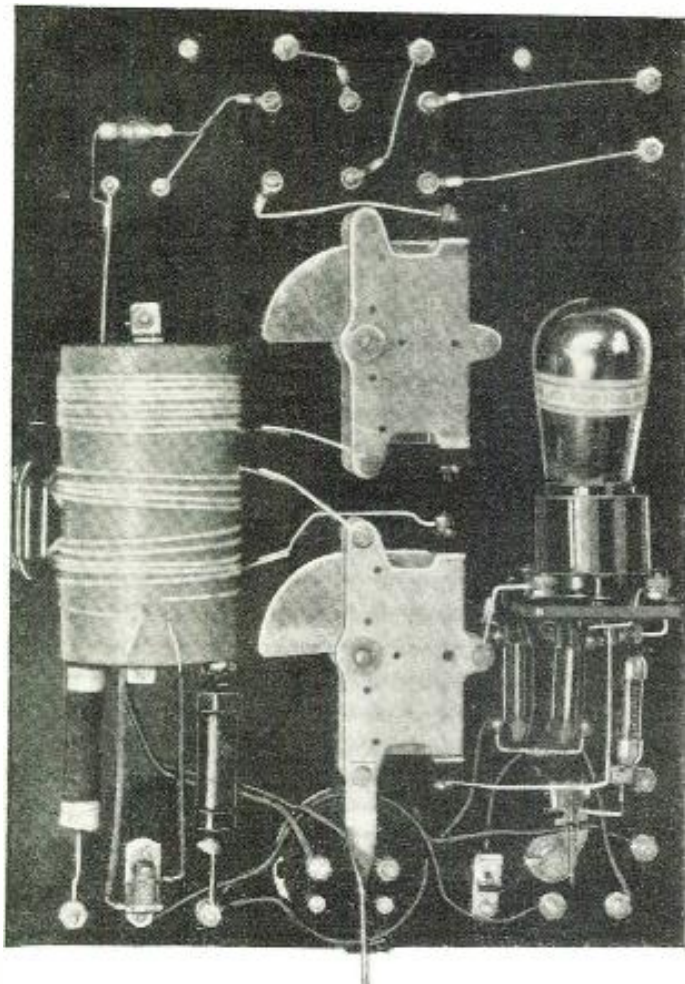

A REAR VIEW OF THE TRANSMITTER SHOWING PLACE-MENT OF PARTS

SHORT-WAVE transmitter designs are legion, and so are multi-wave receivers; but, to provide portability in both instances, is distinctly a horse of another color. And this is exactly what Lieutenant Wenstrom has done in the case of the transmitter and receiver described here.

With a conservatively rated, dependable daylight range of two miles for telephone, and twenty miles for code transmissions, the short-wave transmitter is adaptable to a wide variety of uses—some of which are suggested in the accompanying illustrations. And it is worth emphasizing, that the word “portable,” in this case, is decidedly not a mere figure of speech.

The companion receiver—equally literally portable—covers a range of both short and broadcast channels and is so designed as to accommodate any type of “B” supply available. It also provides for phonograph pick-up, voice amplifier adaptation, and for the use of power audio output where (in fixed locations) the latter is at hand.

The author’s particular fetish, in designing these portables, has been accessibility; a feature especially desirable in equipment which is to be used under camping or traveling conditions.

ideal. Its superiority is shown in the oscillator output table. The figures were secured with a 171A, but apply also to the 171, which is more rugged and generally satisfactory. (See page 33)

Sometimes there arises the question of code versus phone. In reality there is no such question, for a phone experimenter must, under the law, be a code man as well. This is not at all unreasonable, for really good phone work demands a higher degree of technical skill than does code. Code usually has a range ten times as great as equi-powered phone, but phone is very handy when there is a great deal to say.

In choosing the operating band for this transmitter, we must hark back to its primary purpose, which is to cover dependably the distance of an ordinary camping trip or pleasure drive. The twenty-meter and forty-meter bands are unsuitable because of their pronounced skip-distance and because they are not open to phone. Though phone is permitted in the 160-meter band, this band would require too large an antenna. Thus by elimination do we arrive at the best—the 80-meter band. Coil specifications and arrangements are shown in Fig. 5.

Suitable Antennas

The antennas used with this set are described in some detail in the receiver article. Their exact dimensions appear in the diagram (Fig. 2), and the photographs show their construction. The spe-

cial insulators, cut from 3/8" hard rubber rod, are worth noting.

Constructional Details

The construction of a portable, being more exacting than that of a fixed set, should be unhurried. It might be well to start construction and preliminary tests several months in advance of actual portable use. This is particularly true of this

set, as there is no danger of its going suddenly out of date. There are very few parts, and the photographs show clearly how they are assembled and wired. Some experimenters may wish to vary the arrangement. Down the center line and at noted distances from the panel top are: the change over switch, S2, which is removed from its base and mounted directly on the panel (2 in.); the antenna condenser, C2 (5 in.); the oscillator tuning condenser, C1 (9 1/2 in.); and the milliammeter (1 3/8 in. from bottom). The coils of No. 16 D.C.C. wire (except modulating loop of No. 20) are wound on a fiber form 2 1/2 in. by 4 1/2 in. The coils are held rigidly in place by a “dope” of

FIG. 1—THE CIRCUIT DIAGRAM OF THE TRANSMITTER

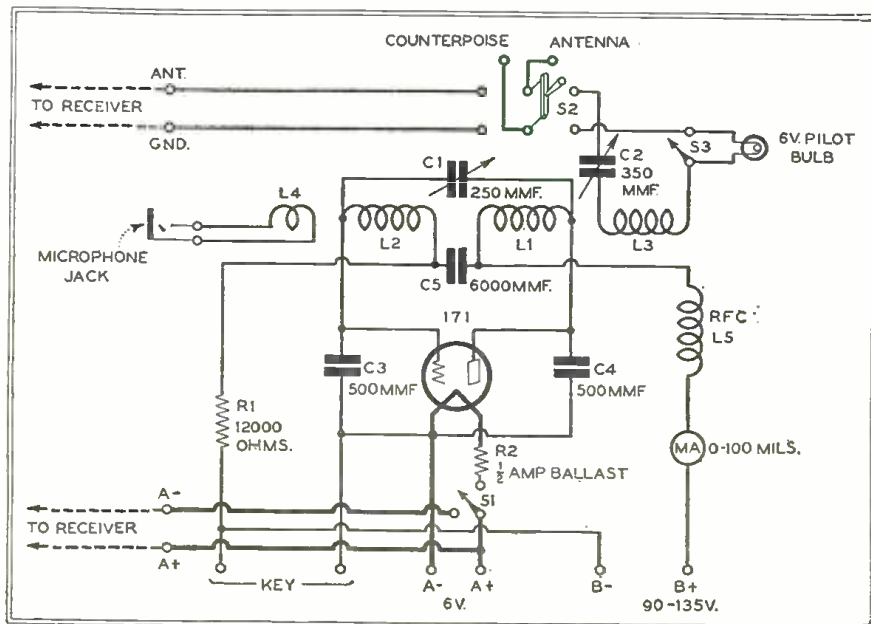

celluloid dissolved in acetone. Of course any "dope" on short-wave transmitter coils is pure heresy, but in this case the most important thing is that they stay in place. The coil form is fastened to the panel by angles on the right (from panel front) of the condensers. The condenser C5 is fastened directly to the center coil ends. Above the coil, to the right of the changeover switch, is the socket for the antenna resonance bulb, mounted directly in the panel; and the shorting switch S3, also mounted in the panel. Below the coil, and held by bus bars, are the grid leak R1 and the radio frequency choke, L5. The latter is about one hundred turns of No. 30 wire on a half-inch wooden cylinder. Below these parts is the microphone jack.

On the left of the condensers is the tube socket, far enough down to have its base even with the oscillator condenser. There is plenty of room above it for a UX-210 tube when the set is used at a fixed location. Directly below the socket and held by bus bar are the "Colpitts" condensers, C3 and C4, and to the left of them is the filament ballast, R2. The filament changeover switch, S1, projects through the lower left part of the panel, balancing the microphone jack on the right.

The carrying case is made of 1/2 inch white pine, nailed together with heavy brads and provided with a suitcase handle. The lumber cutting dimensions follow:

- 1 piece 11 1/8" x 15 1/8" (back)
- 2 pieces 4 1/2" x 11 1/8" (top and bottom)
- 2 pieces 4 1/2" x 14 1/8" (sides)

Though the portable receiver had a front cover this set has none, because its many binding posts do not allow one. For use in an auto, or in any place where it has a tendency to tip over, the box should be screwed to a 1 inch base of convenient size.

The key, and a small knife switch to close the key circuit for phone, are mounted on a separate board 1/4" x 5" x 10". This board is provided with a twisted pair lead long enough so that the key may be used on any convenient rest, such as the operator's knee. The micro-

phone, which may well be salvaged from an ordinary telephone, is provided with a twisted pair lead ending in a plug. To reach the microphone terminals, rather inconspicuous screws on the inner frame, the outer case must be taken apart. The A battery lead is another twisted pair, with battery clips at the far end; or the far end may terminate in a plug which fits a jack on the car dashboard. The B batteries are tied tightly with heavy clothesline into a bundle as compact as possible, and like the other units connect to the set through a twisted pair lead. There follows a list of the parts used in this set, though any parts which are mechanically and electrically similar may be used:

TRANSMITTER PARTS LIST

- C1—Cardwell .00025 mfd. variable condenser;
- C2—Cardwell .00035 mfd. variable condenser;
- C3, C4—2 Sangamo .0005 mfd. fixed condensers;

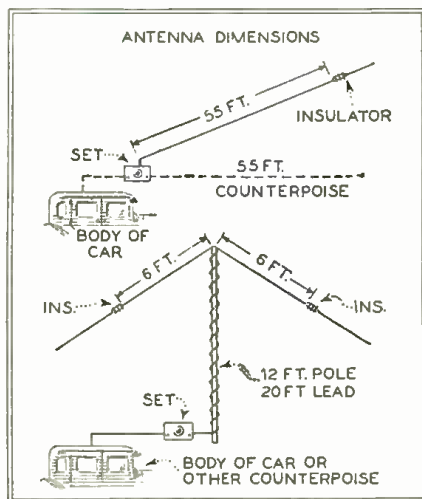

FIG. 2—SOME SUGGESTED ANTENNA SYSTEMS (ABOVE)

BELOW: THE PORTABLE RECEIVER AND TRANSMITTER READY FOR USE IN A COUPE

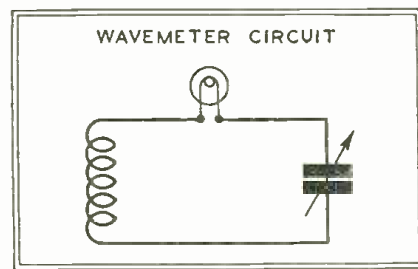
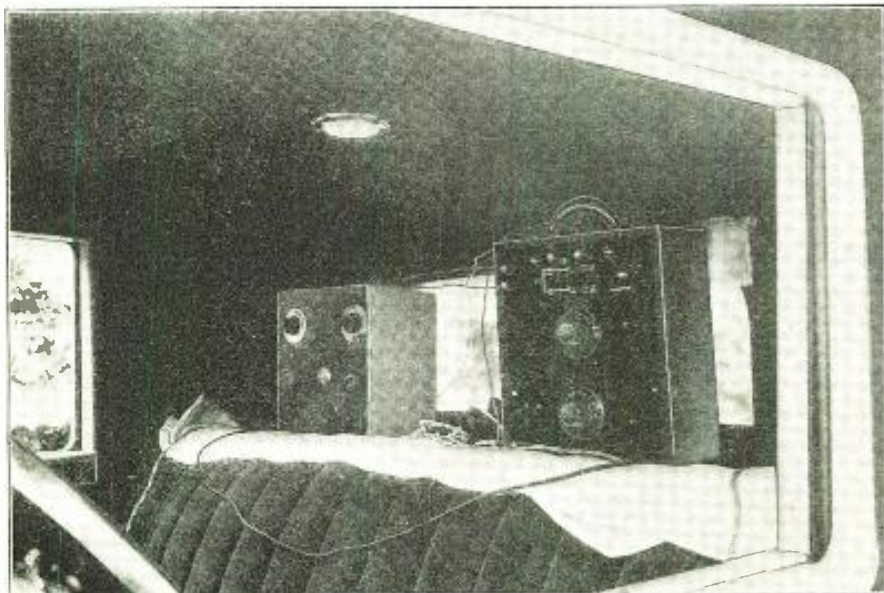

FIG. 3—A WAVEMETER, WHOSE CIRCUIT IS SHOWN ABOVE, IS HELPFUL IN CALIBRATING THE TRANSMITTER

- C5—Sangamo .006 mfd. fixed condenser;
- L1, L2, L3, L4—4 Home made coils (see coil diagram and text);
- L5—Radio frequency choke (see text);
- R1—Western Electric resistance, type 38-B (see text);
- R2—Daven 1/2 amp. ballast, with mounting;
- S1—Yaxley junior jack switch, SPDT;
- S2—Trumbull knife switch, DPDT (see text);
- S3—Midget knife switch, SPST (see text);
- 1—Benjamin spring socket, type 9040;
- 1—Weston milliammeter, type 506, 0-100 mils;
- 2—Dials, 3 inch bakelite;
- 1—Lamp socket, miniature (see text);
- 1—Bulb, 6 v. pilot;
- 12—Eby binding posts, large size;
- 1—Bakelite panel, 1/4" x 10 1/8" x 14 1/8";
- 1—Carrying box, complete.

OPTIONAL HEISING MODULATOR PARTS

- T1—Thordarson small type 2:1 audio transformer;
- R3—R.C.A. rheostat, type PR-535, 0-1.5 —6 ohm;
- R4—Tobe grid leak, .5 meg.;
- L6—Primary of R.C.A. filament transformer, type UP-1656;
- 2—Sockets, Fahnestock clips, baseboard, etc.;
- 1—Two stage speech amplifier;
- 1—Cone speaker.

Before any operation is attempted, a wavemeter should be procured. It is simple enough to make. As shown in the diagram, Fig. 3, its parts are three: a coil, a condenser and a flashlight bulb. The bulb should be of the 1.25 volt variety, as higher voltage bulbs give too broad a reading. Once made, the wavemeter must be calibrated through the receiver from a standard one. Its use is the simplest of all: With the transmitter in operation, place the wavemeter coil near the oscillator and turn the wavemeter dial until the bulb lights brightest. Of course, one must use caution—or a plentiful supply of bulbs.

Operation

First of all connect the "A" battery, see that the tube lights, and check the voltage across its terminals. Then connect a 45 volt "B" battery to the set, leaving the antenna and counterpoise off and setting the oscillator condenser at about 50. When the key is closed the milliammeter should read about 5 mils. Next connect a short length of wire directly between the antenna and counterpoise binding

posts. Tuning the antenna condenser should change the millimeter reading—at one point should almost double it. This test indicates that the tube oscillates normally; but to make sure of it place the receiver across the room from the transmitter, with no antenna or ground on either. The receiver easily picks up the loud cw whistle of the transmitter. Then plug the microphone into its jack, and get someone to talk into it. The telephone signals should be clearly audible in the receiver headphones. It will be noticed at this point that plugging in the microphone lowers the wavelength about a quarter of a meter.

The set is now completely tested and ready for full-powered operation. Actual communication tests should be made from a fixed location before trying portable work. Connect the antenna and counterpoise or ground, and also the 90-135 volt B battery. With the 90 volt battery, the plate current will run somewhat as follows: Antenna detuned, 12 mils; antenna tuned to maximum, 50 mils; normal operation, 25 mils. With the 135 volt B battery: Antenna detuned, 18 mils; maximum, 80 mils (will soon ruin tube); normal operation, 40 mils. As the pilot light reaches normal brilliance at about .1 ampere, one can guess at the antenna current. With the antenna condenser tuned somewhat below the maximum for normal operation, the antenna current runs about .08 ampere for 90 volts and .12 ampere for 135 volts.

Before any real operation, the transmitter must be carefully calibrated—an easy proceeding with the flexible Colpitts circuit. Each new set should be calibrated individually, and a chart like the one in the diagram should be made up. Both the transmitter and the wavemeter may be checked against the receiver on such known wavelengths as 62 meters (KDKA) and 74.7 meters (NAA).

It is worth noting that a Federal license is required for transmission, and that an amateur must stay strictly within the prescribed bands. The 80 meter band extends from 75 to 85.7 meters (4,000—3,500 kc.) for code, and from 84.5—85.7 meters (3,550—3,500 kc.) for phone. While a few careless or deliberate amateurs operate off wave, just as a few drivers labor under the delusion that they own the highways; if every amateur fol-

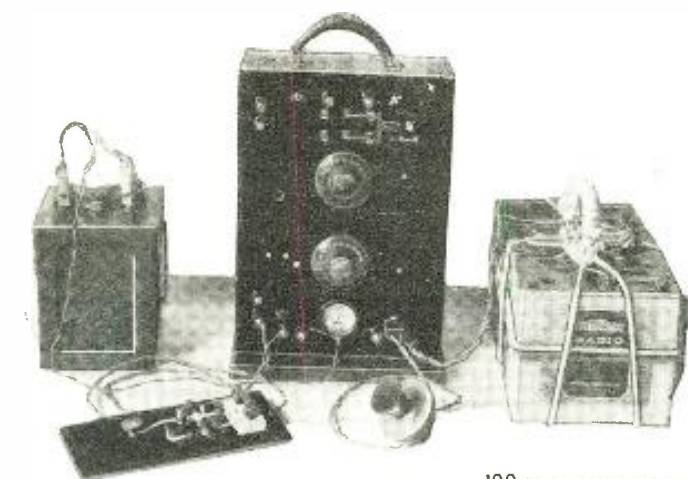

THE 80 METER TRANSMITTER WITH COMPLETE ACCESSORIES. ITS SIMPLICITY AND COMPACTNESS ARE APPARENT

FIG. 6—BELOW, AN APPROXIMATE CALIBRATION CHART OF THE 80 METER TRANSMITTER

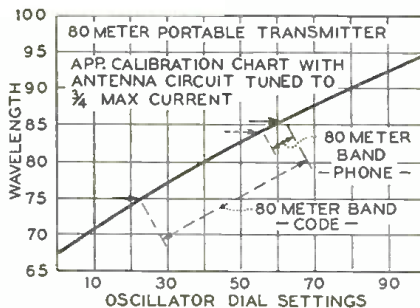

It is best to arrange the first tests with some amateur friend not over 20 miles away. When outsiders are worked later, the operator either tunes in a station calling CQ and calls him when he signs off, or himself calls CQ and searches for an answer in the form of his own call sent by some other station.

The choice of good location will greatly facilitate portable work. Hollows below the general land level and heavily wooded spots are unfavorable to transmission. Electrical conductors, good or bad, absorb radio frequency energy. This absorption is not very important in reception, but the waves should at least be given a fair start from the transmitter. Of course, nothing absolutely stops transmission—submarines transmit under water—but poor locations do cut down the range, and open spaces on water or fairly high ground are best.

When the set is used for some time in a fixed location, more complicated arrangements may be found worth while. For this work a fixed receiver, such as the National Thrill Box or Pilot Super-Wasp, may be used. The transmitter is preferably placed up out of the way in another room and operated by remote control. Since more power is available, a UX-210 can be substituted for the UX-171, and storage battery, generator d.c. or rectified, filtered a.c. may be used on the plate. The plate current runs 45 to 60 mils at plate voltages around 300 or 350. Up to 500 volts may be used if the current is kept down by detuning the antenna.

With increased power, loop modulation becomes unsuitable, and is replaced by Heising modulation. For telephone work the transmitter becomes, in effect, a miniature broadcasting plant. This sounds complicated but, as a matter of fact, the arrangements are quite simple.

(Continued on page 83)

lowed suit the whole fraternity would soon be wiped out by government action.

When the transmitter is used for portable work with the Portable Multiwave Receiver, the binding posts on the left side of the panel are used. The A battery posts are connected by twisted pair to the external battery plug of the receiver, and jumpers run from the upper left binding posts on the transmitter to the antenna and ground posts on the receiver. When using the single wire antenna, a .00025 mfd. condenser is wired in the antenna jumper to change the antenna fundamental so that the 80 meter receiver coil will oscillate normally. To transmit, throw S1 and S2 to the right, lighting the transmitter filament and connecting antenna and counterpoise to the transmitter. To receive, throw both switches to the left, lighting the receiver filaments and connecting antenna and counterpoise to the receiver.

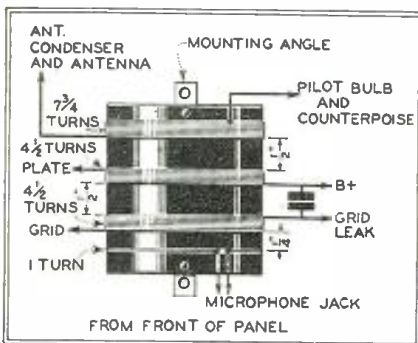

FIG. 5—DETAILS OF THE COIL CONSTRUCTION

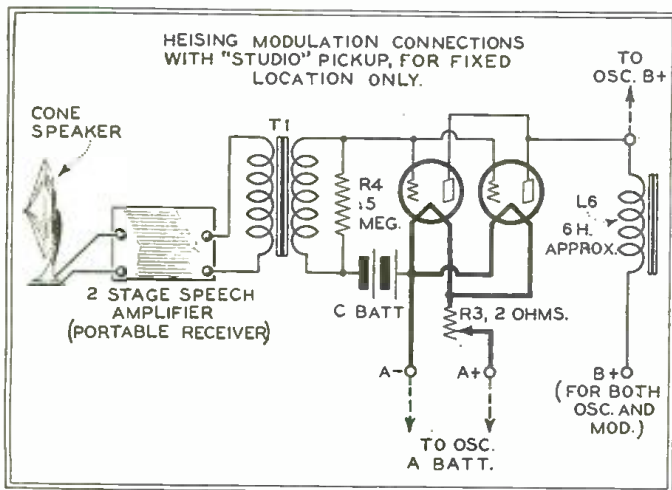
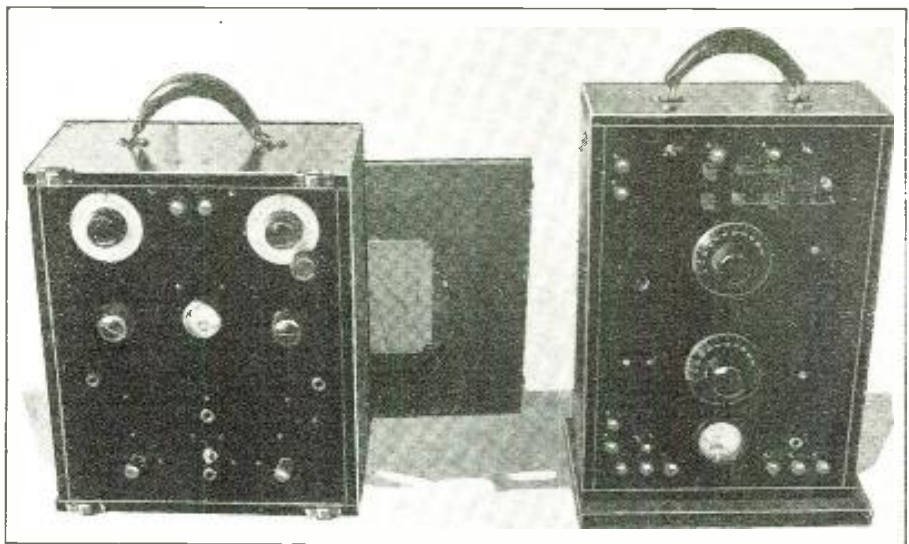

FIG. 4—IN A PERMANENT LOCATION PHONE TRANSMISSION CAN BE IMPROVED BY THE USE OF A VOICE MODULATION SYSTEM WHOSE CIRCUIT IS SHOWN AT THE LEFT



THE PORTABLE MULTI-WAVE RECEIVER, DESCRIBED BELOW

THE TRANSMITTER, DESCRIBED IN THE PRECEDING PAGES

Wenstrom's Multiwave Receiver

A Companion Unit to the Portable Transmitter

PORTABLE receivers maintain a refreshing variety unknown to the more staid and domestic sets of the home. We find puzzling extremes—portables that monopolize a large truck, and portables assembled in a nutshell. The search for compactness can easily be carried to ridiculous extremes: for a thumbnail portable, requiring phones and batteries much larger than itself, gains very little in overall convenience. For real portability, batteries should be included in the set, and the assembly should be of a size and weight easily carried in one hand. These requirements bring us logically to about half-suitcase dimensions; and indicate a carrying box built to fit the set rather than a set crammed into the odd corners of some ready-made container. The design and construction of a portable, needless to say, is more difficult than that of a fixed set.

The circuit used in this receiver and shown in Fig. 1 is easily recognized as a slight modification of the standard regenerative circuit. It covers a wide range of wavelengths. The regenerative detector with one or two stages of audio is practically standard where maximum performance and dependability are desired from minimum apparatus. While the circuit is not as sensitive as some multitube arrangements, it is more reliable and generally satisfactory.

Antenna Design

As the set is ill adapted to loop reception, some form of antenna circuit must be used for everything except local work. Portable antennas are as varied as the sets themselves, but a fairly constant rule is that the smaller and more convenient an antenna, the less signal it picks up. For use with this set three forms have been developed which do quite well for their size. The first is a single wire about 50 feet long, attached at its free

end through an insulator to thirty feet of light clothesline which can be made fast to the highest support that happens to be available. For easy coiling the wire should be stranded, flexible and insulated, like lamp cord; and the insulator should be made from $\frac{3}{8}$ inch hard rubber rod, as the standard types are too large. This antenna is probably the best of all, but in some locations, such as a moving car or a small boat it is not so suitable. For this work we use something reminiscent of the wave coil investigated some years ago by General Squier. Thirty or forty feet of bell wire is wound spirally on a solid bamboo fishing pole eight or ten

feet long, the turns falling about one or two inches apart. The top end of the wire is fastened to the top end of the pole, which of course is vertically upright in use, and the bottom end of the wire is connected to the antenna terminal on the set. The third design, a modified umbrella antenna, is also built on a bamboo pole about twelve feet long; but the bell wire lead is not over twenty feet long with turns widely spaced, and two flexible wires each about six feet long are sol-

FIG. 1. CIRCUIT DIAGRAM OF THE MULTI-WAVE RECEIVER; A SLIGHT MODIFICATION OF THE STANDARD REGENERATIVE CIRCUIT

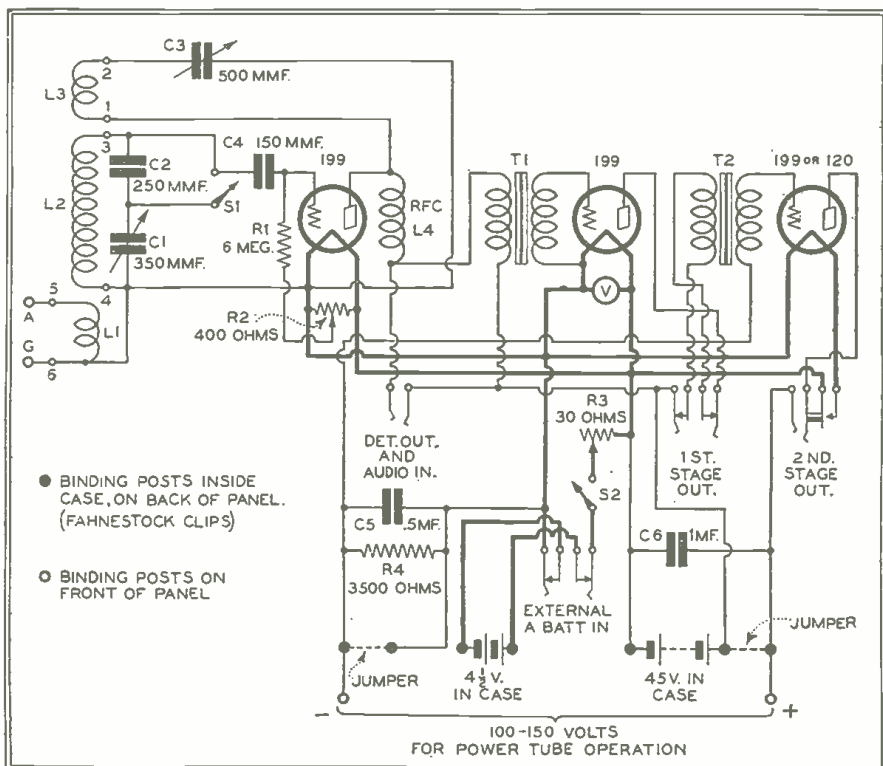

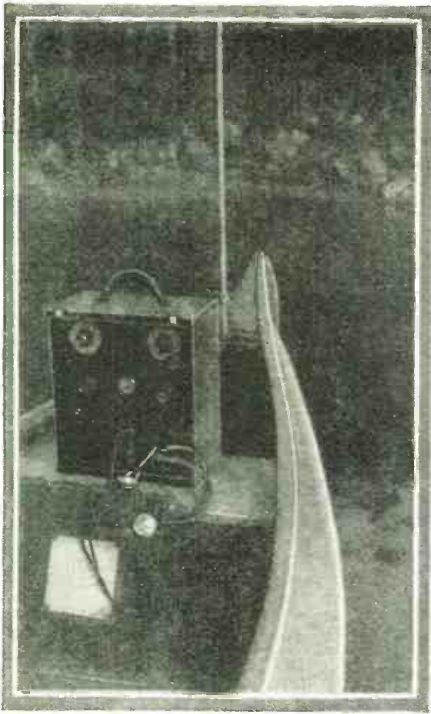

THE RECEIVER, AS SET UP IN A CANOE

dered to the bell wire at the pole top, and held out from the pole at convenient angles by insulators and guy cords at their lower ends.

Unless a good conductive ground exists, such as a water pipe or a metal fence, a counterpoise, or insulated wire laid under the antenna, is desirable. The frame of an auto makes a good counterpoise, as does any large metallic object insulated from the ground. Various makeshift grounds, such as a metal plate or wire in a lake or stream, or a nail driven into a live tree, have possibilities.

Receiver Design

The parts are mounted in a rather unique way—a way that bears some resemblance to the deck construction of a broadcast transmitter. A one-fourth-inch bakelite panel serves not only as the panel but also as the whole frame of the set. Everything except the batteries is mounted directly upon it with no other support. Perhaps each radio designer may be permitted one fetish that he expounds above all others—the writer's happens to be accessibility, and it was developed fixing military sets that had to work but wouldn't. The all-panel mounting is ideally accessible, as well as strong and rigid, for when the panel is slid out of the box and laid face down, all the parts are spread out as on a breadboard.

Tubes of the 199 type are chosen for their small size and battery economy. The rather small gain of these tubes makes two stages of audio desirable even for headphone work. UX-199s might be used with separate sockets; but as a 3 gang shock absorber socket is made for UV-199s these were decided on. The gang socket is more compact, stronger, and easier to mount. As one sometimes wishes to use a loudspeaker on a strong

COIL TABLE

Band	Coil Range	Type	Pri. turns	Grid turns	Tickler
40*	23—45 m.	S.M. No. 111-C, altered	2	5	20
80*	45—92 m.†	S.M. No. 111-B, altered	3	13	35
Broadcast	200—550 m.	S.M. No. 111-A		Unaltered	
Marine	600—1400 m.	S.M. No. 111-D, optional		Unaltered	

*THE FIRST TWO COILS ARE ALTERED FROM SILVER-MARSHALL STANDARD. ON PRIMARIES AND GRID COILS TURNS ARE TAKEN OFF; ON TICKLERS TURNS ARE ADDED; NO CHANGE IN WIRE SIZE.

†THE 80 METER COIL GOES UP TO ABOUT 135 METERS WITH SWITCH S1 CLOSED.

signal and the 199 is entirely inadequate as an output tube, the set is designed so that a 120 tube may be used in the last stage. The Sonatron V-120 fits the gang socket; the UX-120 requires an adapter. The grid bias of this tube is secured from

a resistance in the set, and requires no separate C battery.

Most portables cover only the broadcast band, but this one has a much greater range of usefulness due to its Silver-Marshall plug-in coils. As the broadcast band is considered most important, the circuit constants are arranged to cover it completely with one coil. There is also much of interest between 25 and 100 meters, including the 40 meter and 80 meter amateur bands, so that this range is covered with two coils. An optional coil, chiefly of interest to yachtsmen, covers the ship and radio compass waves. These coils are fully described in the calibration chart, Fig. 2, and in the coil table. Note that the amateur bands are placed well up in the short wave coil ranges, on the flat part of the curve.

FIG. 2. BELOW, A CALIBRATION CHART OF THE PLUG-IN COILS

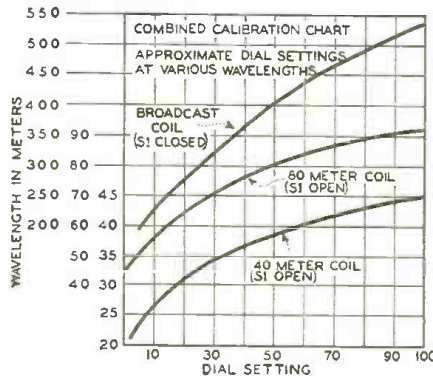

A QUARTER-INCH BAKELITE PANEL SERVES NOT ONLY AS THE FRONT PANEL BUT AS THE SUPPORT FOR ALL PARTS

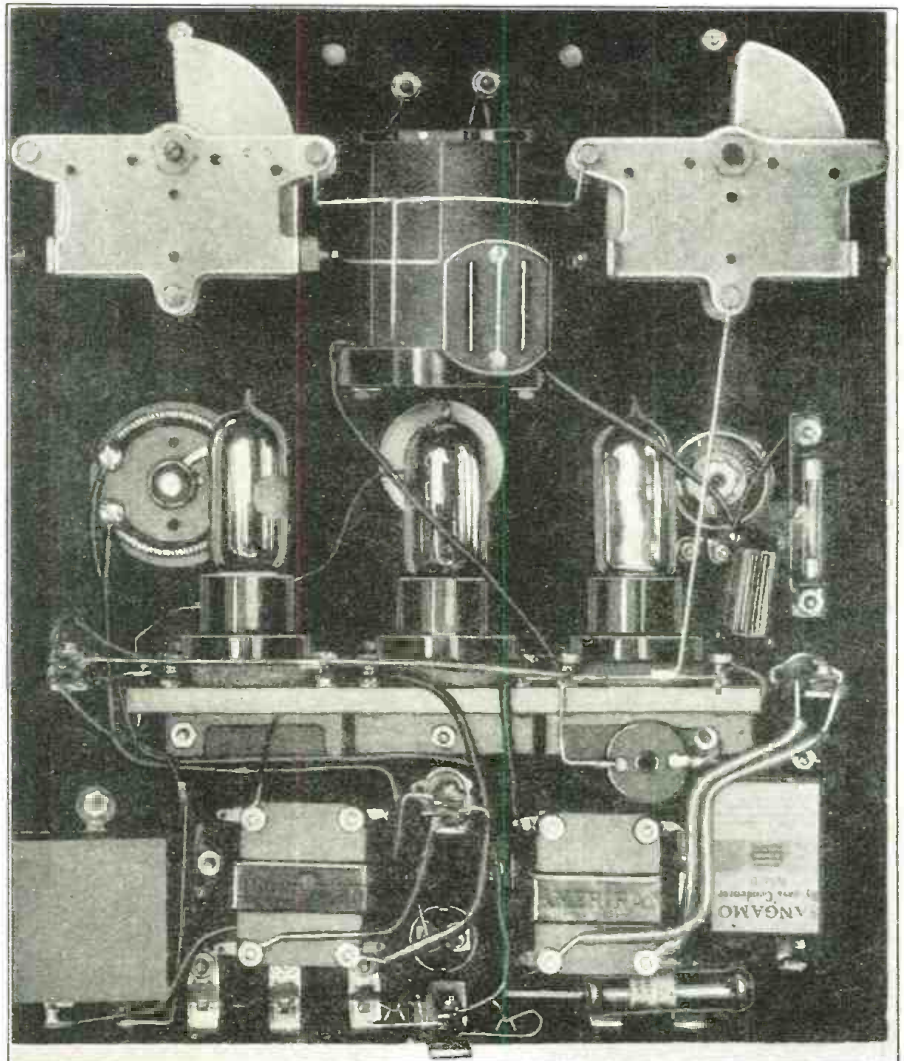

The .00035 mfd. condenser used for tuning through the broadcast band would of course be too large for the short wave coils. We resort to an unusually compact way of getting a smaller tuning condenser for the short waves. A fixed condenser equipped with a shorting switch is wired in series with the variable one. With the switch closed the tuning capacity goes up to .00035 mfd.; with it open the limit is about .000145 mfd. A potentiometer controls the grid bias of the detector and regulates its selectivity and sensitivity. It is usually negative for code reception and positive for phone.

The filament voltage is controlled by a high resistance rheostat and a midget voltmeter. This system permits the use of any A battery, dry cell or storage, and insures correct operation of the delicate 199 tubes. So that different batteries will not affect the amplifier grid biases, the rheostat is wired in the A+ lead.

Though the jack system seems quite complicated, it is decidedly useful. The first jack is across the primary of the first transformer, and serves for testing the detector output, as well as to introduce an audio input with the detector tube removed. This last connection is handy when an electric phonograph pick-up is used, or when the set acts as a speech amplifier. The first-stage output goes to a conventional two-circuit jack. The output jack of the second stage is a filament lighting one, so that the last tube is lit only when in use.

The battery system also seems quite weird at first, but it was planned from much portable experience. The internal A battery consists of two 4½ volt C batteries wired in parallel, the leads from which go to the inside contacts of a double-circuit jack. When an external A battery is plugged into this jack, the internal one is automatically cut out. This external A battery may be three dry cells in series, or a 4 or 6 volt storage battery. If the set is to be used much in a car, the metal dashboard can be drilled for an ordinary open circuit jack. The

NOTE, AT THE RIGHT, THE COMPACT INTERNAL ARRANGEMENT OF PARTS, OF BOTH RECEIVER AND TRANSMITTER

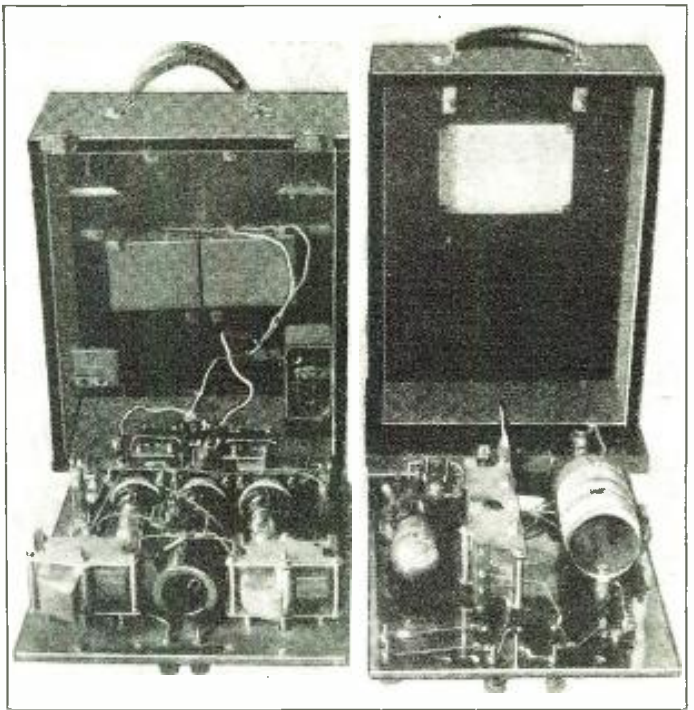

BELOW—ALL LOCAL NEW YORK STATIONS WERE EASY TO GET, ON THE HUDSON, AT WEST POINT; WGY AND WICP ALSO CAME THROUGH WELL

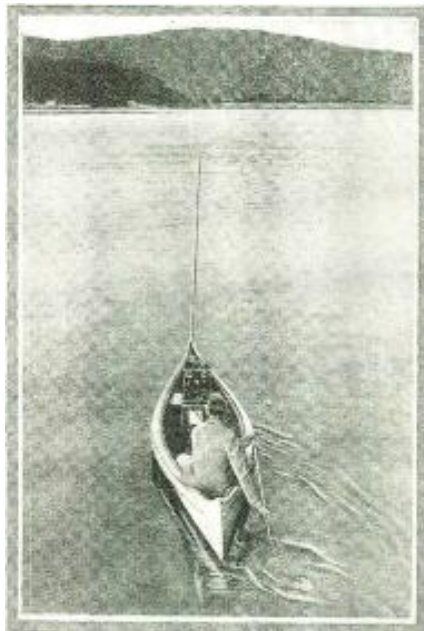

back of the dash near the hole is scraped clean, grounding the sleeve contact, and a wire is run from the tip contact to the ammeter. This jack makes a convenient outlet from the car battery to a radio set or an emergency light.

The internal 45 volt B battery, applied to all tubes alike, consists of two 22½ volt units of the very smallest size (2" x 2½" x 3½"). When a power tube is used in the last stage two jumpers, or short pieces of connecting wire, are removed. This removes the internal B battery from the last tube, and permits to function the resistance which, at the rated current, applies the correct C bias to the power tube grid. The B-C battery for the power tube is then connected to external binding posts. Due to the automatic grid bias, this B-C source can be practically anything between 90 and 150 volts—from batteries or eliminator.

Constructional Details

The arrangement of parts is clearly shown in the photographs. Permissible variations will doubtless occur to the experimenter. The front panel is of bakelite, and measures 11 by 13 inches. Its ¼ inch thickness insures the strength necessary to support all the heavier parts, which are bolted directly to it with machine screws. A few lighter parts are held by bus bar, which is used in some places to strengthen construction. Other connections are made with small, rubber-covered wire. After the panel has been drilled, the mounting of parts can proceed by three distinct sections.

The top section includes the tuning and regeneration condensers, placed close to the outside edges of the panel to leave plenty of room between them for the plug-in coil. The condenser centers are two inches below the panel top. The coil socket is held horizontally by brackets midway between the condensers and 4⅜"

(Continued on page 85)

BELOW—READY FOR REAL WORK, IN THE OPEN COUNTRY



Twenty-Four Hours With

*Twice Around the Clock, on Radio Channels
that Reach Half Way Around the Globe*

By CURTIS GLENN

SLEEP, that demon which trails a human after he has ignored it for 16 hours, has been successfully defied by many people. Adventurers of today have to suppress sleep, for the element of time enters into almost everything. Lindbergh chased it around his cabin for 36 hours and found himself in Paris. Most of us who stayed up that long would think we had found ourselves in a place much unlike Paris and decidedly warmer.

All of which is a rambling introduction to the fact that, being a radio adventurer and deciding to stage a little contest with old man sleep up to 24 hours in length, we seized upon a test with the new National Short-Wave Receiver.

If one has followed short waves they have been loaded down with many serious discussions about the variations in the efficiency of different wavelengths at different hours of the day. With so many opinions and none sounding particularly convincing, we decided to find out for ourselves just what 24 hours on a good short-wave set would do. We would follow the sun around for one revolution and see just what happened.

This test took place in the classic city of Boston, which was the only classical thing about it. We were well supplied with tubes, batteries and other things that are never supposed to fail and probably because of these expectations usually do.

And—who dares say not the most important, was our food supplies. 1GA as "pilot" of the affair evidently thought he had been ordered to accompany Byrd to the South Pole, for he had surrounded himself with a barricade of sandwiches that would have put a wartime Y. M. C. A. hut to shame. Unfortunately, said 1GA has a weakness which did not portend well for the experiment. He likes whipped cream. And how! And you know what whipped-cream strays will do to the inside of a radio receiver. A thermos bottle of coffee completed the picture.

I suggested that Lindbergh had found it much more advisable to eat lightly—that much food made one sleepy. I had not reckoned either with 1GA's training or his appetite. Years of being a ham had hardened him to long watches, and since he comes from Maine, to suggest that he stop eating was like offering him a gun and a dark corner for the deed. It just wouldn't work.

Seriously, in a test of this kind we must have a receiver which will give the test

GETTING the real thrills from short-wave reception is not a matter of sticking to the hours around midnight. On some channels, reception is better by daylight than at night; and, for the real DXer, there is always something on the air.

a chance. We wanted simplicity, plenty of kick, good tone quality. The new National, the latest in short-wave jobs, combined these qualities. It uses an untuned input with a shield-grid tube in the r.f. stage. This is followed by a regenerative detector with feedback controlled by a variable resistance.

Although a complete metal cabinet is provided for it, the effect of this metal being placed too near the coils is eliminated by the use of a "picture frame" base, a bakelite shelf being supported in a picture frame of metal. Thus the coils, plugged into this bakelite base panel, are kept away from metal. Large coils are also used, this combination giving increased efficiency.

A single tuning condenser gives single control tuning. Best of all is the fact that this job can be tuned up to the broadcast band by an ingenious arrangement which throws in an extra section of condenser, a small switch being closed at the time the coils are changed.

The unusual kick of this set is gained by a unique audio unit, two transformers combined in one case. Parallel feed through a resistance couples the plate circuits of the detector and first audio tubes to the succeeding stages, each going into an autotransformer-connected coil, giving a 5 to 1 step-up of a transformer.

This type of amplifier goes even further. It permits the use of a high-mu tube in the first stage, working at its maximum efficiency. Thus we have an audio gain of two 5 to 1 transformers plus a first stage audio giving an amplification of from 25 to 30. We, therefore, knew that whatever signal we picked up would get to us with some pep and quality.

Quality was formerly not considered in short-wave receivers, but with so many stations broadcasting on short waves, the listener wants to hear the music and hear it as well as he does on his broadcast receiver, and better, if possible. Thus the need for high gain yet good quality audio which is really achieved, we believe for

the first time with a two-tube audio amplifier, in this receiver.

But to get back to our test. We decided to listen from the noon of one day to the noon of the next. Thus we could eat a good meal just before starting, the lunch of that day; and just after finishing, the lunch of the next day. This write-up is going very much to food, and perhaps this should therefore appear in *Good Housekeeping*, but we men do like to eat.

Everything was checked, including the commissary, and at 12 o'clock we threw the switch which turned on the works. Quite a few birdies were picked up on the first turn of the dial, and we started back over them and awaited identification. A couple of them turned out to be New York stations. Well, that was a beginning.

More tuning, more waiting. New Jersey came in. Then we began to pick up quite a few hams. Second, third and eighth district transmitters were picked up, and still not much DX. This was the general result up to 3 p.m.

Now we began to get some stations which demanded some good tuning but which the set brought up in good shape. Australia! No, we couldn't believe it, with a signal strength of R4, but sure enough the call letters 7DX verified the land of the kangaroo. That was a jump. Sure the short waves are temperamental. We tuned for three hours to get practically all local stations, and then suddenly pulled in the other side of the world.

This was a sort of anti-climax, if one considers DX from a mileage viewpoint. But it certainly wasn't to us. We wanted to get not only distance, but all kinds. We were now working with 40-meter coils. Hams in the 8th, 9th and 4th districts started to pound in.

Finally we picked up a signal which faded just as we tried to get his call letters. All this was like a fish nibbling at the line. We kept at him and finally got him clearly. FO-A3B, South Africa! Yes, sir! You don't know a thing about radio adventuring until you play with short waves like this.

We looked at our watches: 5 p.m. Well, now it was about time for Europe to come through, particularly with 5SW in mind, for this is the famous station that sends out all the British Broadcasting Company's programs and we had a hankering for some phone reception. This would be a real test of the set.

How would it handle in getting the

a Short-Wave Receiver

oscillation just up to the spilling point? At least we had already proved we were free from "fringe howl," a buzzing groaning sound which short-wave sets often have as you try to slide into oscillation gradually. The trick audio amplifier we have described automatically does away with this conspirator against good phone reception at short waves. But on distant phone, how would it really bring them in?

We tuned in. We picked up several European code stations. Amateurs in France, Spain, England. About 5:30 we landed on a carrier which had a little different sound. That carrier was surely modulated. We backed off on the regeneration, made several fine adjustments on the tuning and then—some good concert music came in. The volume level was high. We could put it on a speaker and fill the room. Then the announcement, "5SW, Chelmsford, England." Now, here was real sport.

Pretty soon I found that 1GA was losing interest in the music. I asked him if he wanted to try something else. No. Then I caught his eyes wandering over the sandwiches, whipped-cream cake and coffee. Oh! Ho! Food was the reason for his sudden loss of interest.

Well, it was now nearing six o'clock, so why not eat? And what was better than dining in Boston accompanied by music from London? Six o'clock struck and then our little repast was turned into a dinner dance, for the announcement told us that the famous Orphean's dance band of the Hotel Savoy was about to regale us with an hour of dance music.

On it came and we were soon chewing our food à la syncopation. All went well until that whipped-cream cake came into the picture. 1GA loaded up properly on that and it was only when I had wasted much time by assuring myself that all the stray bits had been thoroughly removed from his exterior that the test was allowed to proceed. I might add we were getting Chelmsford on 24 meters.

Up to forty meters we went again. Europe, South America and South Africa were heard. Then we began to run into some of the broadcasters who are sending out their stuff on short waves as well as long. Here was a chance to compare broadcasting with short waves.

We plugged in the broadcast coil, threw in the extra condenser and listened care-

fully to KDKA, WGY and WLW. Then we went after them on short waves. They surely came pounding in. The quality was great, better in some instances than at broadcasting frequencies, and this seemed to prove the point that



SOLID comfort is not, of course, essential to success in short-wave reception; but, on a straight twenty-four-hour stretch, it is not to be despised. The author fails to inform us whether the above picture was taken before, or after, the session described in his article. At any rate, there is no evidence of whipped cream.

With memories of the highly complicated, temperamental, and unsightly "bread-board assemblies" so common only a short while ago, this neatly-housed short-waver is something of a revelation. That this compact neatness and simplicity has been attained without sacrifice of efficiency, seems attested by the experience here narrated.

short waves with the small amount of tuning necessary and the tendency to not cut side bands, proved out the point that band pass filtering at broadcast frequencies is the real thing.

Time was slipping. The evening wore on. We had covered most of the earth and made some broadcasting comparisons. We decided to change back to twenty meters again. Europe was not so hot on these coils, but as the evening wore on we noted with joy that Australia was coming up again in good shape and that its neighboring country of New Zealand has its fair share of radio amateurs. Even Japan and China were coming in, but since we have changed to an American hand laundry our Chinese is getting terrible. The difference between the characters and a pictorial description of static is not apparent to us.

Midnight came. Well, the first half of our radio "journey" was over. On we went. Now the Philippines (1HR) came in and finally the west coast stations started rolling along. Suddenly the call

letters WFAT and WBFT were checked among the stations. Yes, sir, that was the Byrd Expedition!

Now all this DXing is good and all that, but tuning in on that adventurous band just did a little something to us that one cannot describe. It was certainly a thrill. Here we were listening to a tiny group of Americans 10,000 miles away on icy areas of the Antarctic. The stuff they sent was a newspaper report of the experiences of the day. Thrilling? I'll say.

Sandwiches and coffee were passed again. The city had grown very quiet. The occasional slow but musical tinkling of the rolling milk wagon assailed our ears. The city for the most part was wrapped in slumber. But we kept our vigil. Soon the first light rays of dawn started to peep in from the east. The sky was lighting up a bit and as daylight approached, our flock of stations we had been receiving since midnight started to fade out of the picture.

Old Sol stuck his head up, decided to stick around a while and then lifted himself up higher for a further look, probably wondering what made a pair of these mad mortals want to stay up all night to listen to funny sounds from little round containers.

District nine announced its presence with a few birdies, this with the 40-meter coils. Then we jumped down to 20 meters. Our old friend 5SW greeted us again and besides we were getting some more phone, mostly voice, this time in some language we could not understand. Gee, but it was coming in even better than Chelmsford. Clearly the man's voice spoke. Then he put on a phonograph record and we could swear we heard the scratch start as the needle touched the disc just before the music started. Then we got the call letters. It was good old PCLL at Eindhoven, Holland. What a beautiful station that must be. It comes in better than any of the other Europeans when it finally does come across.

The morning was wearing on. Our sandwiches had gone, also the whipped-cream cake, also the coffee. We were rather stiff and a little tired and sleepy. There was a chill in the air. Then one of the boys came in. Europe! Surely some fresh hot coffee and coffee-rolls were what was lacking.

Between logging we anticipated the
(Continued on page 84)

How Radio

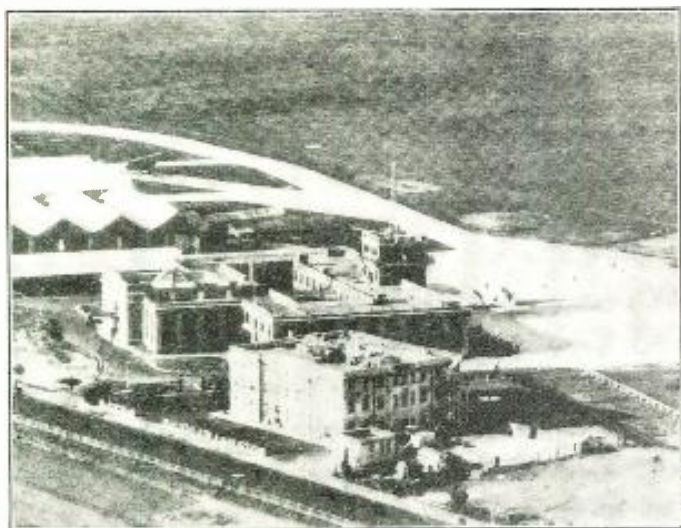

MAIN BUILDINGS OF THE LONDON TERMINAL AIRDROME AT CROYDON, FROM THE AIR

FROM the beginning of air transport development abroad, immediately after the World War, radio communications played a major rôle. Foreign Air Ministries, in contrast to our own Department of Commerce, have not only subsidized and held rigid control of commercial airplane transportation, but they insisted upon reliable two-way radio communication as a primary requisite on every passenger-carrying plane.

As a contrast to European practice, described in this article, we call the reader's attention to Mr. Zeh Bouck's discussion of how radio and aviation interests are cooperating to promote the development of safe and reliable air transport in the United States.



ABOVE IS A CLOSE VIEW OF THE CONTROL TOWER ON TERMINAL BUILDING. IN THIS TOWER ARE THE OPERATORS OF THE AIRPLANE-GROUND CHANNEL, THE RADIO CHART ROOM, AND THE D.F. OPERATOR. THE TOWER SUPPORTS THE TWO FIXED LOOPS OF THE MAIN B.T. DIRECTION FINDER. A VERTICAL ANTENNA AND A RECEIVING AERIAL FOR 1,400-METER WORK

IT is a strange thing that the United States, wealthiest and most powerful nation in the world, should be so far behind the less-favored European countries in its development of aviation facilities. Stranger still, when we consider the comparatively immense distances separating our important cities; a country, in other words, practically "made to order" for the most intensive commercialization of speedy transportation.

Yet the fact remains that this country, which, through the Wright brothers, was

the first to wing its way through the air, is today far down the list of nations which have put these wings to practical use. Not yet are our business men able to understand the nonchalance with which their European cousins utilize air travel as a matter of course.

We have our air mail; second to none. We have our passenger air lines—a few of them. We have our sight-seeing airplane tours from airports in or near most of our larger cities. We have aviation transport companies, prepared to furnish planes and pilots for individuals or parties, on a mileage basis, to almost any part of the country. We have a handful or so of individuals who have become sufficiently "air-conscious" to make frequent use of this newest and speediest means of getting from here to there. But, if you were to ask the man in the street, the average American, his honest reaction to the idea of traveling by plane, it could probably be summed up by the laconic phrase, "Let George do it."

Why? Why are we so slow to develop and apply what we originated?

The answer is very much like the answer to why we were so slow in getting into the late war: It was a thing which didn't particularly interest the average

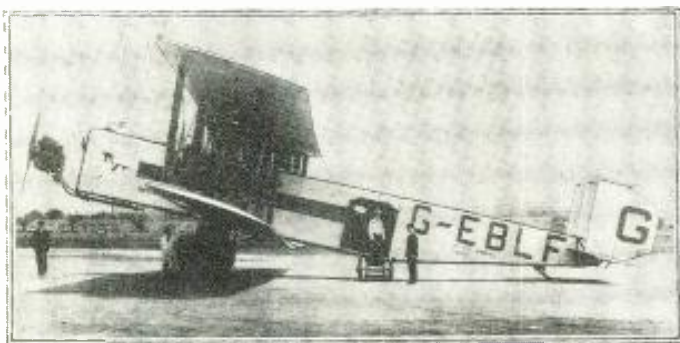

A TYPICAL 18-PASSENGER TRANSPORT SHIP OF IMPERIAL AIRWAYS. IT HAS THREE 500-HORSEPOWER RADIAL ENGINES, AND CARRIES A STEWARD, BUT THE PILOT IS STILL THE RADIO OPERATOR

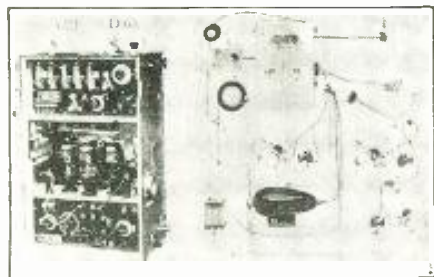

ABOVE IS SHOWN THE MARCONI RADIO SET CARRIED BY THIS SHIP, WHICH IS DESCRIBED AT LENGTH IN THE TEXT. RECEIVER, TRANSMITTER, CONTROLS, ACCESSORIES

AT THE RIGHT IS A PLAN PHOTOGRAPH OF A ROTATING RADIO BEACON OF THE TYPE DEVELOPED BY THE RESEARCH DIVISION OF THE AIR MINISTRY IN CO-OPERATION WITH MARCONI COMPANY, BUT NOT YET IN GENERAL USE. THE WHOLE TRANSMITTER, OF ABOUT 1 K.W. POWER, IS MOUNTED ON THE LOOP ITSELF AND ROTATES AT A UNIFORM SPEED OF 1 R.P.M. A CHARACTERISTIC SIGNAL IS SENT OUT AS THE AXIS OF THE LOOP PASSES TRUE NORTH. WHEN THE PILOT OF THE AIRPLANE HEARS THIS HE STARTS A STOP WATCH HAVING A SWEEP SECOND HAND. HE STOPS THE WATCH WHEN THE SIGNAL PASSES THROUGH THE MINIMUM AND READS HIS BEARING DIRECTLY ON THE DIAL OF THE WATCH. THE BEARING IS SUBJECT TO A 180-DEGREE AMBIGUITY.



Serves Aviation Abroad

By W. THOMSON LEES

Managing Editor

citizen, busy with his everyday worries; he didn't understand it; there seemed to be little to gain, and much to lose. by taking an active part; the whole picture, to the mass of Americans, was a cloudy, controversial thing which had no direct application to John H. Citizen's daily life and habits. That, in 1916, was our feeling about the war; and very nearly that, up to this day and date, has been our feeling about aviation.

The comparison has been made here, deliberately, because the analogy may well be carried further. The same vast forces of education, development and organization that overcame the lethargy of 1916 are already at work. To overcome the ignorance and fear and national indifference that have until now handicapped our progress in aviation. And it is not unduly optimistic to say that we are right now at the threshold of a transformation that will carry this country irresistibly forward to its proper place of leadership.

Among the obstacles which commercial aviation must conquer, the lack of suitable airports—and in some cases the absence of available sites for airports—sufficiently close to the business centers of our larger cities, looms large. Larger still, in the final analysis, looms the psychological factor of popular skepticism as to the safety of flying.

We hear too much about the occasional airplane disaster, and too little about the hundreds of thousands of miles of utterly

eventless flying. The hundreds of planes which daily land without even a bump, are not news; the one, which happens to make a bad landing, also "makes" the front pages of the newspapers. The word "crash," with its distinctly disastrous connotation to the layman, is used in headlines describing the most insignificant minor accidents. So much of the aviator's peculiar jargon has been printed in newspaper articles, that the man in the street has picked up the language without in the least knowing what it is all about.

Meanwhile, the air mail has been quietly establishing an ever-increasing network, and steadily mounting weather and difficult flying terrain. Meanwhile, more and more flying schools have been adding their quotas of trained pilots to

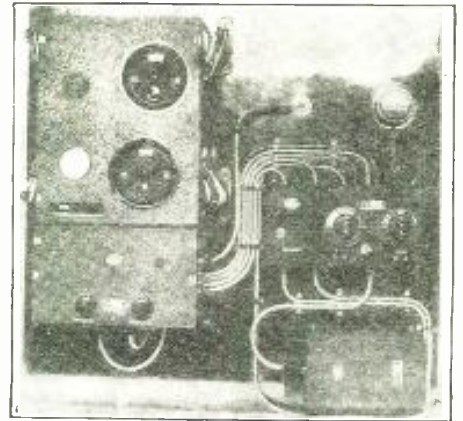

A STANDARD LORENZ 900-METER SET APPROVED BY THE GERMAN MINISTRY OF COMMERCE. THE TRANSMITTER IS RATED AT 100-120 WATTS. THE WHOLE SET WEIGHS 106 POUNDS, INCLUDING THE WIND-DRIVEN GENERATOR. THE GENERATOR HAS FOUR WINDINGS; 24 VOLTS, 220 VOLTS, 2,000 VOLTS, AND 15 VOLTS AT 1,000 CYCLES



AT THE LEFT IS A VIEW OF THE SIGNAL TOWER, THE GROUND-TO-PLANE TRANSMITTING ANTENNA, AND THE TERMINAL BUILDING, AT BERLIN, GERMANY



THIS SHOWS THE TYPE OF STOP-WATCH, HAVING THE DIAL DIVIDED IN POINTS OF THE COMPASS, WHICH IS USED TO FACILITATE THE TAKING OF BEARINGS WITH THIS BEACON

the small nucleus with which the army and navy supplied us when the war ended. Meanwhile, more and more commercial transportation companies are entering the field; planes are being manufactured in larger and larger quantities; airports are increasing; more and more inter-city routes are becoming established, on regular schedules. And, coincident with these visible steps of progress, the aforementioned psychological handicap is being attacked from two sides: on the one hand, by an intensive campaign of education designed to teach the layman the actual truth about the advantages and the safety of flying; on the other, by scientific research directed toward still further improving the present factor of safety of airplanes under every conceivable condition.

In the last-named connection, radio is playing a major part. Here, too, however, we have until now lagged behind the European nations. Abroad, there are many passengers and express air lines

which have been in regular operation for a number of years, maintaining a high percentage of regularity and safety. An important contributing factor has been the maintaining of radio communication and position-finding. While it is unlikely that this country will follow established European practice in detail, it will be well worth our while to study some of the experience acquired there.

From the very beginning of commercial aviation, abroad, European transportation companies have held two-way communication between plane and ground to be of first importance; with position-finding second, and the various other navigational aids following after. Foreign government air ministries have encouraged primarily the development of communication equipment; a policy in direct contrast to that of our own Commerce Department. The latter has centered its initial activities in the broadcasting of weather information and in the development of directive radio beacons, leaving

the matter of two-way communication to be worked out by the aircraft operators in cooperation with commercial communication companies.

England, France, Germany, Holland and Belgium follow much the same uniform plan in controlling and promoting the growth of aviation. In each of these countries, the subsidized transport company and the manufacturer of radio equipment work in intimate relationship, together with the Air Ministry or Ministry of Commerce, to promote the safety of air transportation. As typical of the close alliance between radio and aviation in those countries, it is interesting to consider in some detail the scheme of operation employed in England.

The Imperial Airways, in England, operates a passenger and freight service to the principal European capitals, local service to the Channel Islands, a service to India. Marconi Wireless Telegraph Company is the accredited manufacturer of radio equipment, and the government agency in control is the Communications Division of the Air Ministry.

The Air Ministry compels the provision of two-way communication facilities on all transport planes operated out of London. Equipment for this purpose is designed and built by the Marconi Company, with the assistance of the Air Ministry, and is leased to Imperial Airways; fees being based upon the mileage of successful radio operation. The sole basis for computing these are the pilots' reports. Last year, acceptable radio service was reported for 95 per cent. of the total miles flown.

The Communications Division of the Air Ministry maintains a limited ground inspection service at Croydon, cooperating with the Marconi Company's maintenance service. The Air Ministry also acts as advisor on all new radio installations, checks pilots' reports, and acts as arbiter in case of disputes.

Imperial Airways' present standard radio equipment consists of Marconi's A.D. 6h, 150-watt set, designed for telephony, I.C.W., and C.W., but used only for telephony. The transmitter has one speech amplifier, one modulator, and two oscillators in parallel. The receiver has one untuned circuit, one radio amplifier

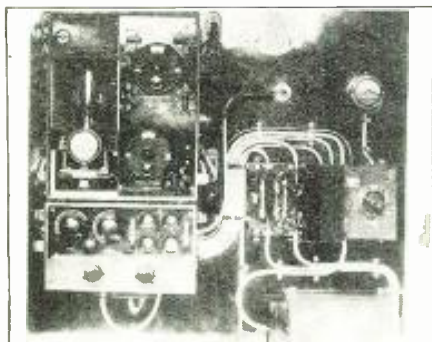

THIS SHOWS THE LORENZ SET, WITH THE COVERS OFF. THE TRANSMITTER IS A SINGLE 120-WATT TUBE OPERATED THROUGH A TANK CIRCUIT INTO THE ANTENNA. THE RECEIVER HAS TWO TUNED CIRCUITS, ONE RADIO STAGE, DETECTOR AND TWO AUDIO

tuned circuit, one radio amplifier tube with feedback coupling, two resistance-coupled radio amplifier tubes, detector and one audio amplifier. A trailing wire antenna is used exclusively, and power is supplied from a wind-driven generator with self-regulating propeller, combined with a floating six-volt storage battery. The dead weight of all equipment is 104 pounds.

The pilot is the only operator; all ships carry a mechanic, and the first-class ships carry a steward. Sometimes the mechanic has a radio helmet, but he never uses the microphone or tuning controls except in case of emergency. All communication between plane and ground is on 900 meters and the minimum daylight range is considered to be 100 miles.

The ignition shielding varies with the types of installation. Shielded spark plugs are not used and no attempt is yet made at the complete suppression of all ignition interference, without which the average American pilot refuses to listen to radio. The Imperial Airways pilots stand a continuous radio watch while the ship is in the air and years of experience have enabled them to hear and interpret signals in the presence of real ignition noise.

AT THE RIGHT IS A SIMPLE DOUBLE ANTENNA MOUNTED ON ANOTHER AIRPLANE OF THE D.V.L. WITH THIS INSTALLATION AN EXTENSIVE SURVEY OF THE FREQUENCIES FROM 20 METERS TO 60 METERS HAS BEEN MADE. ON COMMUNICATION FROM PLANE TO GROUND, WITH A CONSTANT POWER OF 2 WATTS IN THIS ANTENNA, C.W. COMMUNICATION TO THE GROUND CAN BE CONTINUOUSLY AND RELIABLY MAINTAINED UP TO DISTANCES OF 300 MILES FROM THE RECEIVING STATION

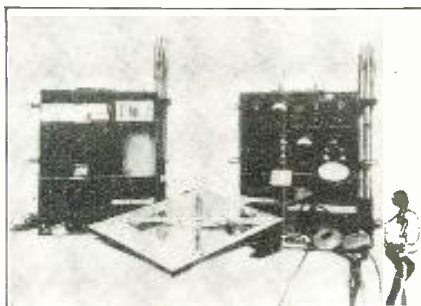

THIS PICTURE IS INTERESTING BECAUSE IT SHOWS ONE OF A NUMBER OF SHORT-WAVE SETS DEVELOPED FOR SPECIAL USES. THIS IS AN EMERGENCY SET OPERATED FROM AN EDISON "A" BATTERY AND 100 VOLTS OF DRY "B" BATTERY. IT IS CARRIED BY SOME OF THE LARGER LUFT HANSA SHIPS. THE TRANSMITTER IS CRYSTAL CONTROLLED, ADJUSTABLE FOR 45 TO 105 METERS, DEPENDING UPON THE CRYSTAL. THERE IS PROVISION FOR A SPARE CRYSTAL. ALSO, THE CRYSTALS HAVE A FUNDAMENTAL FREQUENCY OF 41 METERS. THE ANTENNA IS A HORIZONTAL WIRE 2 METERS HIGH AND 3 METERS LONG, SUPPORTED BY THE COLLAPSIBLE MASTS. THE RECEIVER IS A THREE-TUBE REGENERATIVE RECEIVER

The pilots are now the first to complain of failure of the radio service, however. They refuse to fly without it and may

even turn back with a shipload of passengers if they suspect a local fault.

The radio equipment is not only installed in the same place in the airplane, but the most usual location is the forward partition, inside the cabin, with the Bowden cable control run through the bulkhead to the pilot's seat.

In addition to supervision of communication equipment, three ground services are maintained by the Air Ministry: a 4 kw. ground phone transmitter, operating on 900 meters, for transmission of weather reports, orders and position reports; a point-to-point dispatch and meteorological service, carried out on radio channels in the neighborhood of 1,400 meters, from two other 4 kw. ground stations; a position-finding service, carried out by triangulation with three ground direction finders.

The main one of the three direction finding stations is at Croydon; the other two are located respectively at Pulham and at Lynpue. Request for bearings are received on 900 meters, the pilot then sends a bearing signal for 30 seconds. bearings are taken by three direction finders, the position is noted on the chart at the main station at Croydon, and the position is transmitted to the plane on

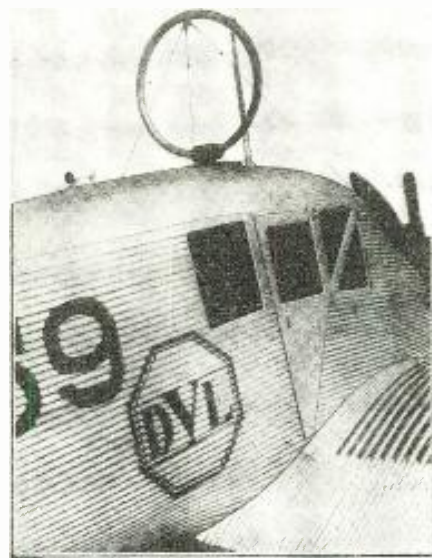

the 900 meter channel. The maximum time allowed for the whole operation is 1½ minutes, and it is frequently carried out in less than a minute. No other radio aids to navigation are in use.

The airplanes are landed in thick weather by continuous transmission of positions from the control tower at the airdrome. The first automatic aid to air navigation which is likely to be used in England is the rotating beacon, which has been thoroughly studied in the past three years and in which the Air Ministry is now much interested.

Radio operations of Luft Hansa, the German air transport service, are similar in plan and scope to those of the English, but they are carried out with a more extensive organization and greater attention to detail because of the fact that the Luft Hansa is more liberally subsidized, and the German Commerce Ministry also carries out a more extensive

radio research program. For instance, the Luft Hansa plane, from Croydon, always carries in addition to the senior and junior pilots a radio operator, whose sole duty is to sit at a regular operator's bench inside the cabin and handle traffic. Until across the channel, the operator will be in communication with Croydon by phone, but will not be very busy unless the weather is thick. As soon as he crosses the border into Germany, however, the operator will start work in code on I.C.W. with the central radio station of the district in which he is flying, and from there on to Berlin about 90 per cent. of his flying time will be taken up getting weather reports, orders for the pilots, and transmitting messages for the pilots.

At the Tempelhof airdrome at Berlin, the center section houses the radio office, operators' rooms, a radio test shop, and a school for operators. The central building is the terminal, housing ticket offices, customs, waiting rooms and restaurant.



STREAMLINE ROD ANTENNA INSTALLED ON A NATIONAL AIR TRANSPORT MAIL PLANE, FOR BEACON SERVICE

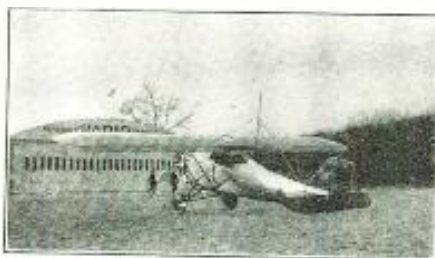

A TEST PLANE OF THE AIRCRAFT DIVISION OF RADIO FREQUENCY LABORATORIES, BOSTON, N. J.

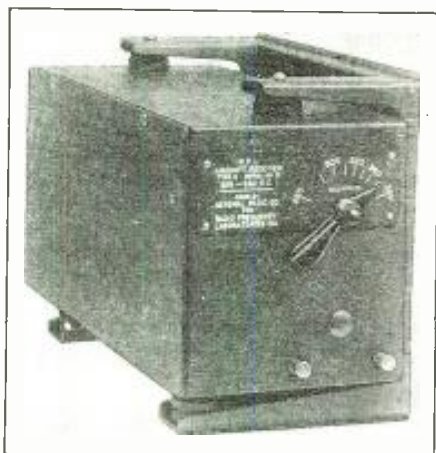

AIRCRAFT BEACON RECEIVER DEVELOPED BY RADIO FREQUENCY LABORATORIES AND MADE BY THE GENERAL RADIO COMPANY

In front (as one approaches the field) is the signal and control tower.

At the DVL, near Berlin, Germany has what is probably the finest aircraft radio research plant in the world. Many German engineers are of the opinion that the present standard ground triangulation system will be replaced by direction finders on the airplanes rather than by radio beacons. This conclusion may be influenced by the fact that their planes always carry a radio operator. Incidentally, it is interesting to note that a simple loop direction finder, enclosed in a metal housing, can be made to work satisfactorily and without serious or erratic deviations, on an all-metal plane.

German engineers have also made extensive surveys of plane-to-ground communication on from 20 to 60 meter channels, using a simple double antenna mounted on one of the DVL airplanes. They have maintained constant and reliable C.W. communication with the ground, up to the distances of 300 miles, with a power of 2 watts in this antenna.

At LeBourget field, outside Paris, the French Air Ministry owns the hangars and rents them to transportation com-

panies, but until the latter part of 1927 no attempt was made to interest the air mail contractors in the use of radio equipment on their mail planes. Even now, eighteen months later, only a few of the air contractors have definite plans for establishing two-way communication between plane and ground.

When the aircraft radio research agency of our Commerce Department, comprising a section of the Bureau of Standards, undertook after the passage of the Air Commerce Act of 1926 to develop radio aids to air navigation and to interest transport lines in their use, the problem of communications and communications equipment were left at the outset to commercial concerns, and the government interested itself entirely in radio directive and navigation equipment, such as the radio beacon. When the results of their research began to receive practical application at the hands of the Bureau of Lighthouses (who are responsible for installation and maintenance of the airways) the latter Bureau added a weather broadcasting service which is being rapidly extended. But the methods and extent of the use by operating companies of the radio aids already established have been left almost entirely up to the operators, aided by private enterprise.

Our government has no activity which even approaches the direct supervision exercised by the British Air Ministry over communications on the Imperial Airways, and no agency has the power to compel or define the extent of the use of radio or commercial air lines. Perhaps this will never be necessary, since the operating companies who propose to carry passengers on a large scale have at the outset taken the attitude that the safety of their service is entirely their own responsibility. Those companies who intend to carry passengers or who are already doing so, now feel quite generally that communications to and from the ground must come first, and radio beacons and other services second. This will involve the development of their own communication systems, the construction of ground stations and the equipment of airplanes substantially without government aid. Constructive steps in this direction have been made in the past two months by the formation of cooperative associations between many of the operating companies who use the same airports. The purpose of such associations will be to provide common ground facilities, maintained on shares, to avoid duplication of work and excessive congestion of the short wave channels available for communication.

panies, of which there are five in active operation. Varying slightly in detail, the general scheme of operation here, as in Germany, is comparable to that already discussed at length in connection with England's aviation and communications control. The Air Ministry's control in France, however, seems somewhat more loosely maintained than in Great Britain.

Returning now to America we find an aircraft radio situation which has great possibilities with regard to the development of new methods and equipment, but which is now in a rather disorganized and uncertain position owing to the huge size of the country, the varying nature of the proposed transport services, and the large number of transport companies who have entered the field without definite policy of communications. Radio is generally considered to be a useful but not a vital accessory to air transportation. We are justly proud of our air mail service, which is the only type of air transport that has been in operation for a length of time comparable with the duration of the European passenger services. The Department of Commerce maintains a network of point-to-point communication by radio channels between the principal air

IT is well to bear in mind that, while we have been slow to develop aviation in this country, that slowness has in no way been due to lack of willingness to cooperate, on the part of radio and telephone technicians. As a matter of fact, in commenting on the recent demonstrations of two-way communication between planes and ground, the Bell Telephone engineers stressed the fact that *their* part of it had been ready for many months.

A Tube and Set Tester for a Lean Purse

A Practical, Home-Made Device that Does Away with "Hit-or-Miss" Methods

By M. K. BARBER

BEING an experimenter and set builder in a small way, and having long felt in need of a good tube tester and set analyzer, but not having the necessary seventy-five or eighty-odd dollars with which to purchase a real good one; and, being too fussy to be satisfied with a low-priced one equipped with a couple of cheap meters and having limited adaptability, I decided to get the old brain and pencil working to devise a tester which would approximate the adaptability of one of the real good ones at the cost of one not so good. I also wished to have all the test connections aboveboard, where I could see what I was doing—rather than "throw switch A to the right and switch B to the left" just because the directions said to do so; and thus add somewhat to my knowledge of radio testing.

The following paragraphs and the accompanying diagrams describe a general-purpose tube and set tester which may be assembled by anyone at a cost of approximately fifteen dollars, and which will enable the set-owner quickly to locate any trouble his radio set may develop. In addition, it will keep him advised of the condition of his tubes and batteries or eliminator voltages, and so he may anticipate and correct the cause of about ninety-five per cent of all set failures.

FIG. 1.—THE SCHEMATIC CIRCUIT OF THE TUBE AND SET TESTER

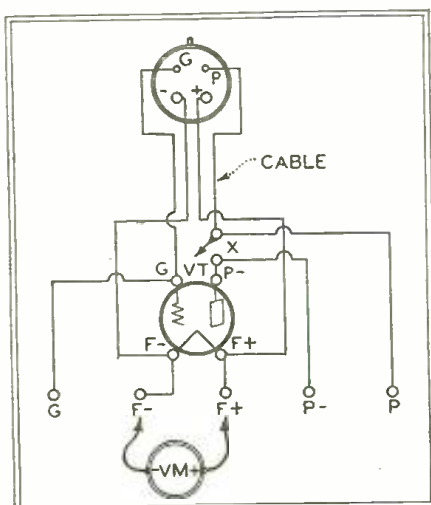

THERE are a number of excellent set testers on the market. But the service man or experimenter whose work of this nature is only occasional, hardly feels justified in investing a large sum in testing equipment.

Here is an answer to that very problem: a practical device that is not only easy to construct, but well within the means of the leanest purse.

Any radio receiver and its accessories may be tested, with the aid of only three simple pieces of equipment. These are: a voltmeter, a milliammeter, and a single, high-resistance phone receiver. If the resistance of the voltmeter is known, and is of a suitable value, it may be used either as a voltmeter or as a milliammeter, and its range in either capacity may be extended to cover all normal requirements, by means of a variable resistance which will handle about five watts for a few seconds at a time.

You say, "I have an old phone receiver and a rheostat in my junk box. I will get a voltmeter and so be equipped to do all my own testing." Suppose you lift the cover of your radio set and look at the works. In the majority of sets, this is what you will see: from five to seven tubes with their bases set flush on a metal subpanel; two or three variable condensers; the upper edge of a rheostat; a box with a covered cable extending down under the base; and a metal case or two containing audio transformers or whatnot. No wires or terminals are visible.

Now, where are you going to connect your voltmeter or phone receiver to make your first test? You lift out one of the tubes and it occurs to you that if you could clip the voltmeter across the socket terminals you could test the various circuits connecting to that socket. So you could, but to make the test complete you must also keep the tube in that socket and have the set turned "on." The main purpose of any tube and set tester is to enable you to do this.

Look at Figs. 1 and 9. At the top is a tube-base plug to be inserted in a tube

socket of the set. It is connected by a cable to the tube test socket (VT) mounted on the tester panel. Five pin-tip jacks are connected to VT. The tube we removed from the set is inserted into VT. Our voltmeter is equipped with a pair of short, flexible leads having a pin-tip on each. Switch X connects the plate prong of AD either directly to the plate of VT, or opens this lead for connecting a milliammeter in series with the plate.

Now look at Fig. 2. This shows an amplifier stage in the receiver. The "doughnuts," except P—, indicate the four terminals of the tube socket in the set. They also, including P—, indicate the five pin-tip jacks on the tester. To which the socket terminals are connected through the four-wire cable and its plug, AD. The circles marked GF, FF, etc., indicate the various voltmeter connections which are made by plugging the voltmeter test cords into the pin-jacks. VT indicates the tube plugged into the test socket. The tests obtained by the various voltmeter connections shown are as follows:

FF tests continuity of filament circuit and voltage drop across filament. If it is desired to read the full "A" battery voltage, minus the small drop in the filament leads and rheostat, simply withdraw the tube from VT. A separate a.c. voltmeter, of the tube-base plug-in variety, is provided for testing the filament circuits of a.c. sets.

GF— tests continuity of grid circuit in amplifier stages biased with a "C" battery. This also shows the negative voltage applied to the grid, and, if the volt-

FIG. 2.—THE VARIOUS TESTS ON THIS AMPLIFIER STAGE ARE EXPLAINED IN DETAIL IN THE TEXT ON THIS PAGE

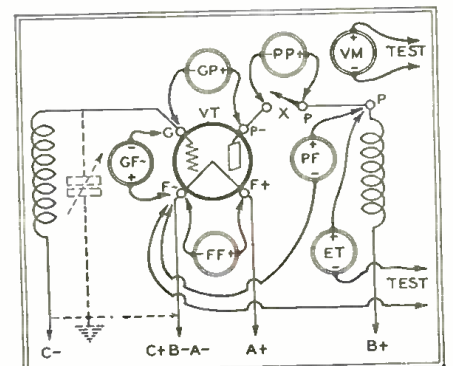

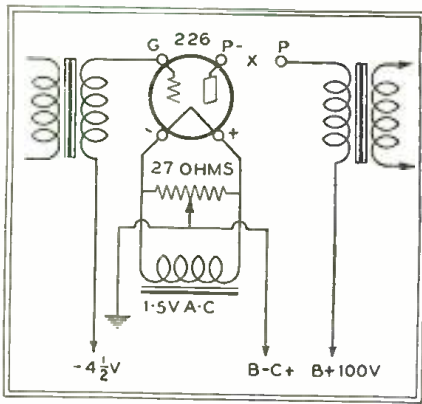

FIGS. 3 AND 4, ABOVE AND AT THE RIGHT, SHOW THE CONNECTIONS TO THE TEST SET WHEN TESTING, RESPECTIVELY, A D.C. AND AN A.C. AMPLIFIER STAGE

age of the "C" battery is known, the voltage drop across the transformer secondary. GF+ makes use of the "A" battery for grid continuity tests in those stages having no "C" battery bias.

GP tests the continuity of any grid circuit except those detector and R.F. amplifier stages, in some sets, which have a condenser in the grid lead and a grid leak shunting the tube input terminals. In such a circuit the voltmeter will show a small deflection due to current flowing through the grid leak, but to test the continuity of the transformer secondary it is necessary to short out the grid condenser with a test cord and clips. In a detector circuit where the grid leak shunts the grid condenser, any deflection of the voltmeter indicates the continuity of the grid circuit.

PF tests continuity of the plate circuit and voltage applied to the plate. If the full voltage of the plate battery has been determined, the difference between the two readings is the voltage drop through the plate coil, or plate resistance, or both, as the case may be. PF- includes the "A" battery voltage where A plus and B minus are common.

PP tests the plate current when switch X is opened. Plug AD into an amplifier stage having the correct "A," "B" and "C" voltages for the type of tube under test and compare the voltmeter deflection obtained with a similar reading taken with a tube which is known to be good.

Directions for reading the plate current directly in milliamperes are given in a following paragraph. Remember that any change in the filament rheostat, grid bias, or plate voltage while making plate current comparison tests will cancel the readings previously taken.

ET is for external testing. This connection places the voltmeter and "B" voltage from the set in series with a pair of test cords for the purpose of testing circuits or apparatus separate from the source of the testing voltage. Know your circuits well before prodding around inside of the same set in which you have the test plug.

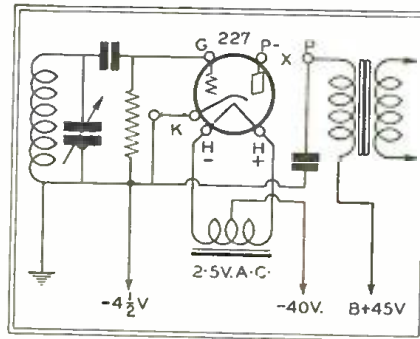

VM is simply the voltmeter with a pair of long test leads and it is safe to use this test even though the plug AD is in one of the set's tube sockets. The leads should be insulated to within one-eighth inch of the points, to avoid danger of a short circuit. All continuity and voltage drop tests are conveniently made by connecting VM negative to B negative and using the VM positive lead for probing each circuit from B plus up to its ending at a tube terminal. It is as-

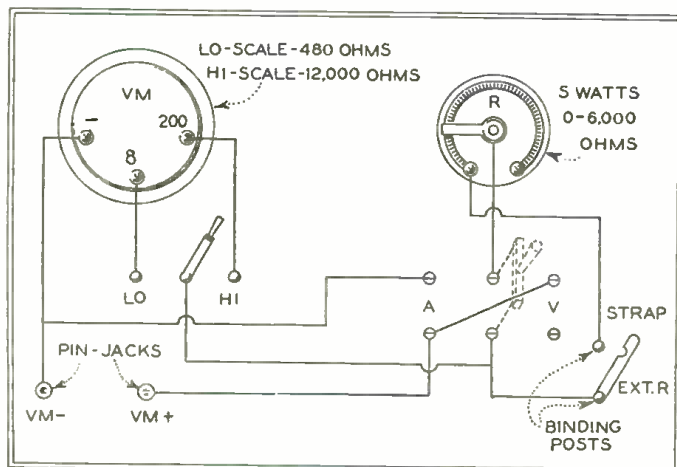
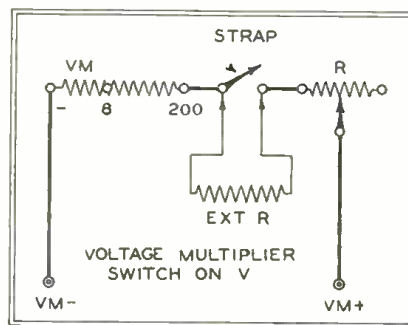

FIGS. 5, 6 AND 7, SHOWING CONNECTIONS FOR THE RHEOSTAT, SERIES-PARALLEL SWITCH (AV), VOLTMETER (VM) AND VOLTMETER SWITCH (LO-HI), ALSO VOLTMETER PIN-JACKS AND BINDING POSTS FOR CUTTING IN EXTRA RESISTANCE

sumed that the set has been removed from its cabinet and turned up on a work table for this kind of testing.

Figs. 3 and 4 show the connections to the test set when AD is plugged into an amplifier stage of an a.c. set, and into a UY socket through a UX-UY adapter. In the latter case, a UY-UX adapter is inserted into VT and the cathode connection between the set socket and the adapter socket is completed with a flexible test cord having a clip connector on each end. This cathode connection may be omitted, for most of the tests, by connecting K to one of the heater terminals, H, on the UY-UX adapter.

Figs. 5, 6 and 7 show the connections of the rheostat (R), series-parallel switch (AV), voltmeter (VM) and voltmeter switch (LO-HI), also voltmeter pin-jacks, and binding posts for cutting extra resistance in series with R. Figs. 6 and 7 are schematic diagrams showing the connection made when the switch AV is operated towards either V or A.

VM is a double range, 0-8-200 volts d.c. instrument having a resistance of 60 ohms per volt on either scale; i.e., 480 and 12,000 ohms for the 0-8 and 0-200 scales respectively. By Ohm's law, 16.666 milliamperes will cause a full scale deflection on either scale. Of course, 25 times the voltage of the 10 scale, or 200 volts, must be applied across the HI scale terminals to cause the same current to flow that 8 volts applied to the LO scale will cause to flow. It is better to use the LO scale, with a suitable value of shunt resistance, for all plate current measurements, where the current to be measured is larger than 16 milliamperes, because the reading thus obtained will more nearly approximate the current reading obtained by the use of a standard milliammeter. This is because the lower resistance in the plate circuit will allow a larger current to flow. 16.666 milliamperes divides itself into 2.083 milliamperes per each one-volt division on the LO scale. This may conveniently be called two milliamperes per volt, or one milliampere per each one-half volt division, and amounts to a direct reading, 0-16 ma. scale, for all practical test purposes. A milliammeter of this range will handle the plate current of any tube up to a UX-171 in size, where not more than 135 volts are used on the plate of the 171 and with a grid bias of 27 volts negative. For larger plate currents to be measured, a shunt resistance is necessary.

The resistance R is a wire-wound potentiometer of 0 to 6,000 ohms range and five watts capacity, with reverse rheostat

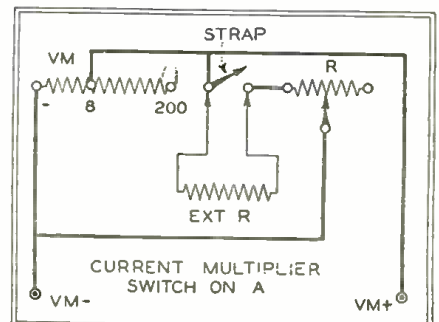

connection for direct resistance calibration on a two-inch clockwise dial. Though a 0 to 500-ohm rheostat would provide sufficient resistance for all current multiplier values to the LO scale, and the two binding posts provided allow the connection of a higher resistance in series with R for voltage multipliers to the HI scale, the resistance described above is of greater utility. R must be completely short circuited when rotated to the zero resistance position of the dial. The extra rheostat carried for the voltage multiplier resistance may be one of the carbon compression type with a range of from about 200 ohms to 30 megohms, though 24,000 ohms will triple the range of VM and is the most that will be needed. To the writer's knowledge there is no variable resistance on the market which has the necessary range (0 to 24,000 ohms), the required current handling capacity, and that is also small enough to be mounted in place of the one first described above. in the small space available on the tester panel. Such a high resistance in one unit would be most difficult to adjust on the lower values required as a current multiplier to the LO scale.

Adjusting R to the value required for use either as a voltage or current amplifier to VM is a very simple operation. For example, if a range of between 200 and 400 volts is required, connect VM to as high a voltage as can be obtained,

for the cord will do as well. The socket adapters, except the UV99-UX, are improvised from Pilot sockets and old tube bases.

It is only necessary to drill a No. 6 hole through the bottom of the tube base, ream out the eyelet which holds the Pilot subpanel socket together, solder pieces of tinned hook-up wire to the socket terminals, push the wires through the proper prongs of the tube base, and bolt the whole assembly together with one 6/32 machine screw. Trim off the ends of the wires which protrude from the tube base prongs and solder them to the prongs. Even the tiny UV-199 tube base is quickly and easily converted into a UX-UV199 adapter in this manner.

The panel is hinged to the back edge of the box and held closed by two thumb-screws (improved from old style brass binding-post screws, nuts and split-washers) in the front corners. The size of the panel and box, which can be home-made, may be any size desired by the constructor, but the size described here permits the carrying of all necessary accessories, including a few tools such as pliers, screwdrivers, wrenches, files, etc., a small flashlight, a telephone receiver with cord and plug, and the adapter cord and plug AD, within the box and with a minimum of waste space.

A metal handle is bolted to the back, and four rubber-headed nails on the bottom corners prevent the marring of any polished surface upon which the tester may be set. When in use, the adapter cord protrudes through a notch cut in the side edge of the box, near the socket (VT) to which three of its wires are terminated; the fourth or plate lead terminating on one side of the switch (X), which is near to VT.

(Continued on page 84)

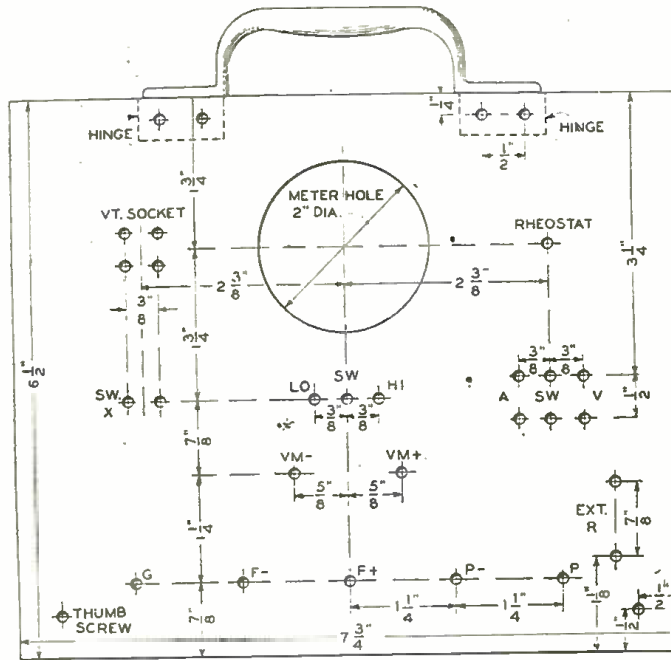
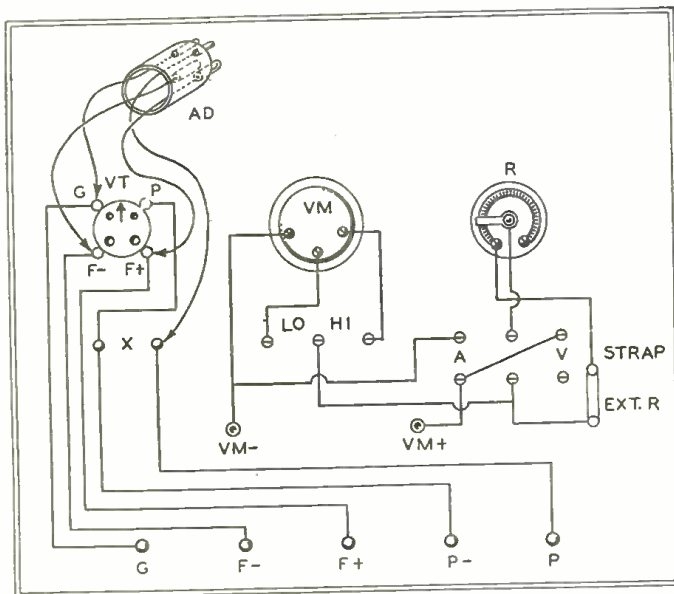

FIG. 8.—THE PANEL LAYOUT

AV is operated to the A position after the first reading is taken, for the resistance adjustment.

Figs. 8, 9 and 10 show the complete wiring diagram, the panel layout, and the dimensions of the box used by the writer. The box used once housed a Radiola III, and the five-wire battery cable from the same set (unused wire cut off) is used for the adapter cord. The adapter plug (AD) was improvised from a CX-199 tube base and a section from the handle of an old electric soldering iron. A piece of broomstick with a hole drilled lengthwise



up to 200 volts, and count the unit divisions of the scale from zero to the point of needle deflection. A voltage multiplier constant of two is desired.

Cut in enough resistance to bring the needle back to one-half of its former deflection and the range has been doubled. The method of increasing the milliamperage range is similar, except that the switch

FIG. 10 DIMENSIONS AND DETAILS OF THE CARRYING CASE USED BY THE AUTHOR ARE SHOWN AT THE RIGHT

FIG. 9 AT THE LEFT IS THE PICTURE DIAGRAM OF THE PARTS AND WIRING OF THE TEST SET

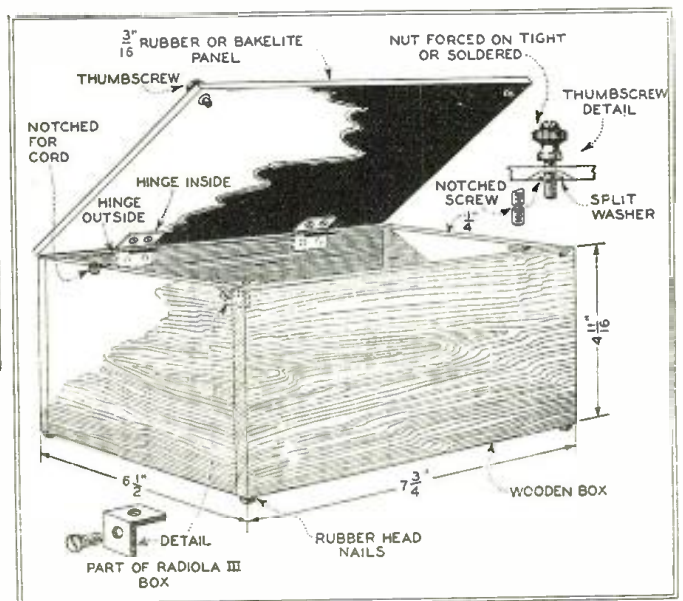

Opportunities in the Audio and Radio Arts

By CARL DREHER

Chief Engineer, R.C.A. Photophone, Inc.

FORMERLY one talked to young men about opportunities in radio. First that meant radio telegraphy, the art of sending messages through the air from shore to ship, or ship to ship, or one continent to another. Then radio telephony, in the form of broadcasting, became prominent in everyday life, and the term "radio" expanded its meaning. But the process did not stop at this point. The implements of radio—meaning principally the vacuum tube—and its technique, spread rapidly into other fields of technology, until now those fields, and the activities of life based on them, comprise a formidable list.

At the present stage wire telephony, on which modern business and social life depends more than on any other communication instrumentality, needs the vacuum tube, born of radio, for everything beyond local connections, and for most of its measurements. The electrical phonograph has in large measure superseded the mechanical form, and the mechanical form was vastly improved by the application of electrical principles. The phonograph recording art has been wholly electrified. The expanding airplane field utilizes radio communication, both by telegraph and telephone, in order to increase its safety factors and convenience to the public. Public address systems are used everywhere to bring speech and music to large numbers of people. The combination of sound recording and large-scale reproduction has revolutionized the movie field and, it appears, will dominate considerable portions of the theatrical business in general. A host of relatively minor applications, each important in some specialty, might be cited.

In the meantime, the original art of radio telegraph communication over land and sea has not decreased in importance, but, on the contrary, takes its place with the cables as a means of communication between continents, and, utilizing short waves as well as long, links the most isolated places—rubber plantations, movie companies on location in the South Sea Islands. Antarctic exploration bases—to the great industrial centers.

In all this vast and complicated activity there are great opportunities for men with the right preparation and qualities. The qualification is important. Usually we think of "opportunity" as a chance to succeed, to acquire money, power, and the less tangible things which men desire.

SPEAKING with an authority gained by actual experience and first-hand observation, Carl Dreher outlines, or rather summarizes, here the preparation an embryo engineer or technician must undergo to fit himself for a field which is one of the most attractive of the electrical arts.

Readers who have felt the urge at one time or another to "break into the game" will do well to ponder over Mr. Dreher's valuable advice, as given in the two hypothetical cases of John and Tom.

But unless the right factors are present the "opportunity" may simply be a chance to fail.

Since my own background is largely technical I shall confine myself, in this article, to the technical or semi-technical field. For the benefit of young men it should be stated, first of all, that in general technical positions pay less than commercial jobs. The salesman gets his first grab, so to speak, at the company's income, and, other things being equal, he gets a larger share of it than those in more remote positions. In our economic

system it is more of a problem to keep the machinery going, by the devices of salesmanship and advertising, than to create new machines and their products. The first piece of advice, therefore, to the young man who wants to get rich as quickly as possible, and who has the requisite gifts of plausibility, aggressiveness, commercial shrewdness, and charm of personality, is to get into sales or advertising, or commercial engineering, rather than into the technical field. This is not to say that money cannot be earned in the technical field also. It can be done, and it is easier now than it used to be, but it is still harder than in the commercial branches.

Specific examples teach more than generalities, so we shall discuss two hypothetical cases. The first concerns John, a young man who, after completing his high school course, becomes a marine radio operator, then a broadcast operator, and now aspires to get into the talking movies. We shall follow his career, outline his economic progress, and discuss his future prospects.

John completes his high school work at the age of eighteen, say, and, having been

THE R. C. A. PHOTOPHONE GRAMERCY STUDIOS, NEW YORK CITY. NOTE THE RECORDIST, VISIBLE THROUGH WINDOW OF THE SOUNDPROOF BOOTH, AT EXTREME LEFT

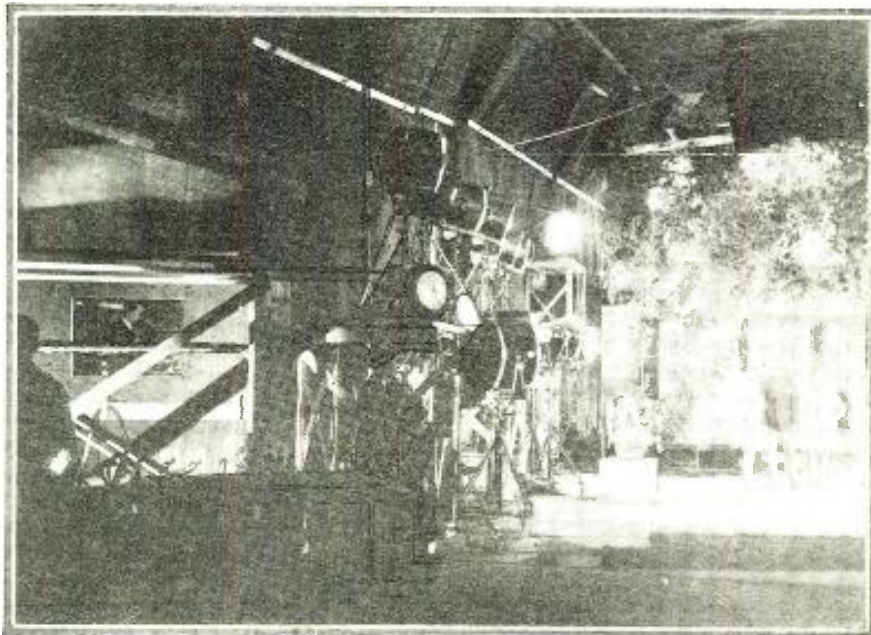

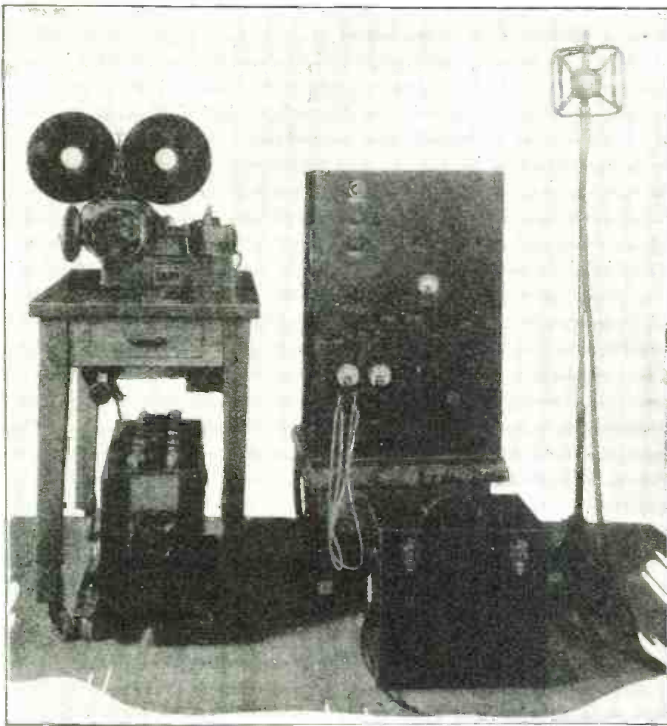

R. C. A. PHOTOPHONE RECORDING EQUIPMENT SHOWING MICROPHONE, AMPLIFIERS AND RECORDER, LOOKING FROM RIGHT TO LEFT

larger and more desirable vessels, and after a few years he may expect to become a senior operator himself, at about \$125 a month. There is some leisure for study, contact with the public, and the advantages of travel are his. On the other hand, there is a tendency to become lazy, since the business life of the operator, as such, is restricted, and he is thrown on his own resources for broadening experience. If John's ambition is confined to standing his eight- or twelve-hour watch (generally in four-hour tricks), eating his meals, reading the *Saturday Evening Post*, and sleeping, he becomes just one more middling radio operator. A stage is reached where he wants to get ashore, and there is very little open to him. Generally he then leaves radio and goes into some other business.

If, on the contrary, John has continued to enlarge his knowledge of the technique of radio operation, traffic handling, and public service aspects of the communication business, he will attract the attention of his superiors and, when he wants to go ashore, there will be a job for him. For that matter, there may be good-sized opportunities at sea—the large liners run telegraph offices, nowadays, which require the services of a staff of operators, a maintenance technician, and a managing operator with a responsible position paying \$200-\$300 a month clear. If John goes ashore, however, to marry, or because traveling no longer appeals to him, he may receive something like \$150-\$250 as an operator at a land station. He can then climb to various administrative posts in the long distance communication end, or in marine work, or in the airplane branch. For the purpose of our discussion, however, we shall assume that his thoughts turn to broadcasting.

"SHOOTING" A SOUND-MOTION PICTURE AT THE R. C. A. PHOTOPHONE GRAMERCY STUDIOS, NEW YORK CITY. THE MICROPHONE MAY BE SEEN SUSPENDED AT THE LEFT

ONE TYPE OF PORTABLE EQUIPMENT USED BY THE N. B. C. "NEMO" GANGS, MEMBERS OF THE FIELD SUPERVISORS' GROUP, WHO ARE RESPONSIBLE FOR REMOTE CONTROL PICK-UPS OF PROGRAMS ORIGINATING OUTSIDE THE STUDIO

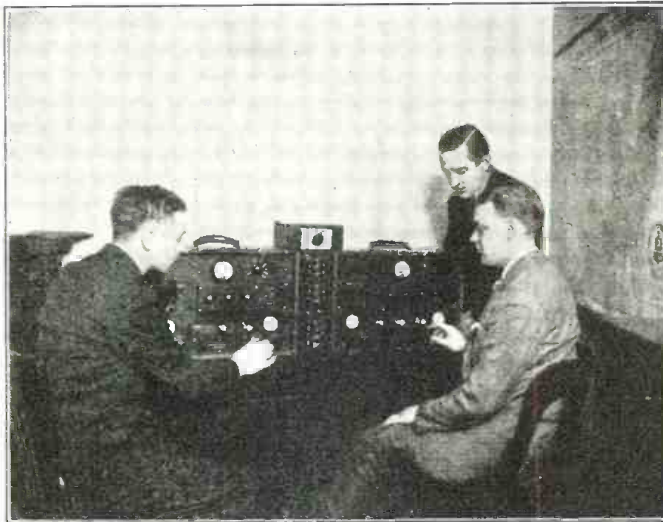

interested in radio as a broadcast listener or a telegraph amateur, decides he wants to see the world as a radio operator. He may already be so proficient in code work and the elementary theory of radio that, after a study of such books as Sterling's "The Radio Manual," or Nilson and Hornung's "Practical Radio Telegraphy" and "Radio Operating—Questions and Answers," he is qualified to pass the government examination, and, equipped with a commercial radio operator's license, to seek a job. The chances are, however, that he will have to take a six-months course in a radio school to fit him for a position as a junior radio operator on a ship. He may have to wait some time for a job, depending on the state of the shipping business. When he gets a berth his pay will be of the order of \$75 a month, a considerable part of which he can save, however, since his meals and room are provided in addition. If he gets on well with his senior operator the job is a pleasant one. As John's proficiency increases he is transferred to

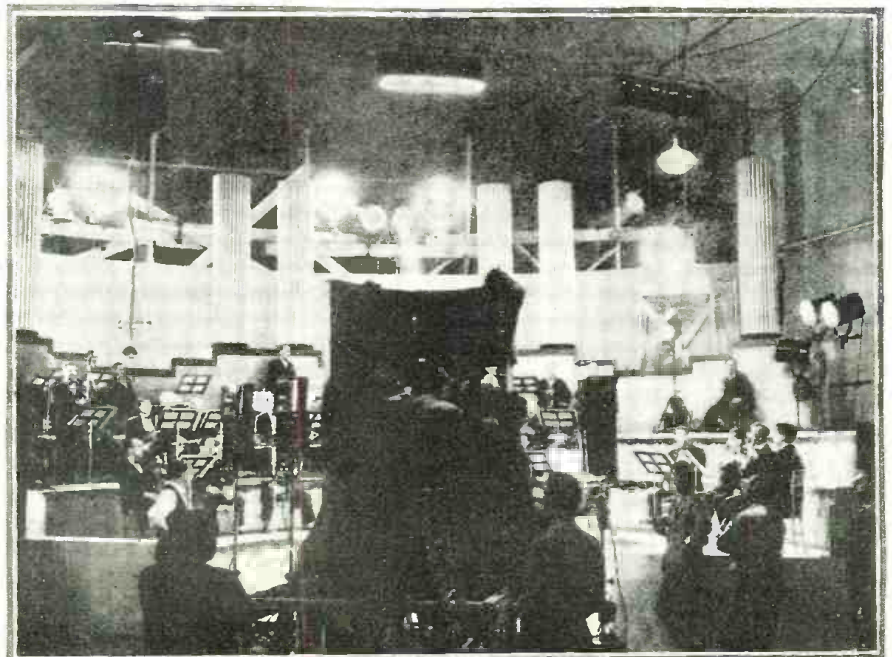

Here again the element of preparatory study plays an important part. John applies to one of the broadcasting companies for a job. The managing engineer lets him fill out the usual blanks and questions him. If John is just one more wireless operator who wants to get ashore, his application is filed and heard of no more. On the other hand, John may have been reading up on broadcast technique, acoustics, amplifier design, and wire transmission in such publications as the *Proceedings of the Institute of Radio Engineers*, the *Journal of the American Institute of Electrical Engineers*, and the *Bell System Technical Journal*. He may not have assimilated everything in the papers he has read, and his knowledge of the subject may be largely theoretical and uncoordinated, but the attitude is what counts with the man who has a position to fill. If he hires John he will probably pay him \$200 a month, the usual starting salary in the big broadcasting chains for well-qualified men of the age of twenty-five or thereabouts. Younger men get less, usually in smaller stations than those attached to the chains.

In the broadcast business John must accustom himself to the niceties of judging musical balance, adjusting amplifier gain just enough and not too much, throwing the right keys at the right instant, studying new and intricate circuits, and getting on with people of temperament and training which differ widely from his, such as advertising men, publicity representatives, musicians, artists, and clients who run their own business and must be

firmly but oh, so politely dissuaded from trying to run the broadcasting plant also. If he can meet the technical and psychological qualifications, there is no reason why he cannot advance to a supervisory position, where he may have charge of network transmission, or one of the radio transmitting plants. Salaries in this line run about \$300-\$550 a month, depending on responsibility, age, etc. The lower figure is within the reach of a capable broadcast operator, even without administrative responsibilities. Then there is always the possibility, for men with the requisite personal qualifications, of a transfer to the sales or advertising field, where impressive emoluments are not unusual.

We shall assume, however, that John now aspires to a place in the talking movie game. If he is wise, he will carefully balance the arguments pro and con, and base his decision more on what he knows of his own aptitudes than on the immediate advantages of one course or the other. At the present time the movie



A FULLY EQUIPPED TRUCK FOR THE RECORDING OF "TALKIES." SOUND AND PICTURE APPARATUS MOUNTED IN A TRUCK IS USED FOR RECORDING SOUND PICTURES OUTSIDE THE STUDIO

A MEMORABLE OCCASION. RETUNING THE TRANSMITTER OF WEAH AT BELLMORE, LONG ISLAND, AT THE TIME THE FEDERAL RADIO COMMISSION'S NEW ALLOCATION OF TRANSMITTING FREQUENCIES WENT INTO EFFECT

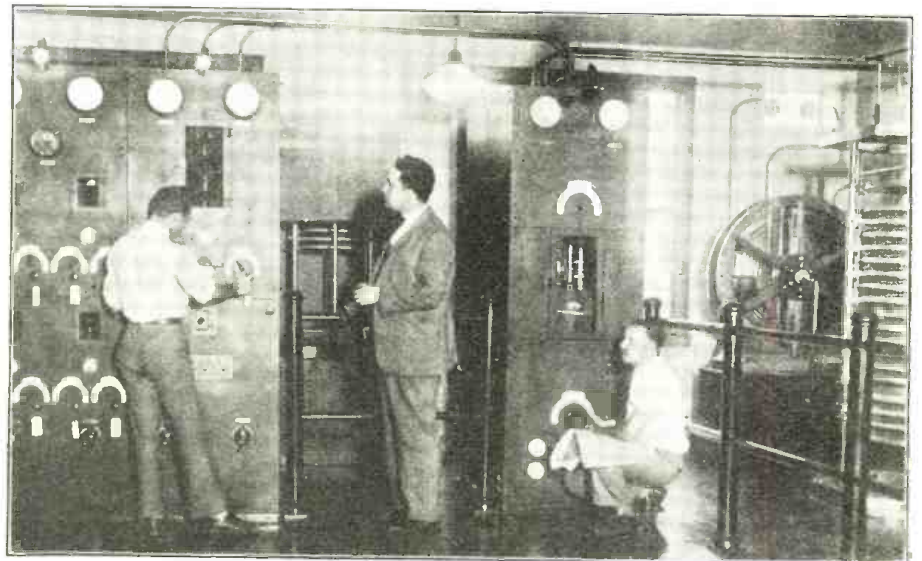

J. J. BELOUNGY (SEATED), ENGINEER-IN-CHARGE OF THE N. B. C. TRANSMITTER AT BELLMORE, L. I., AT THE RADIO RECEIVING SET TUNED AT ALL TIMES TO 600 METERS FOR "SOS" WATCH



companies offer relatively high salaries to the audio technician. Even if he lacks first-rate technical training, given a good practical knowledge of microphone placing, amplifier adjustment, and acoustics, and the ability to adapt himself quickly to new conditions, he may earn \$300-\$800 a month. But he must be prepared to learn a new business, and to compete with the people who have long been established in that business and who are, perhaps, quite as capable of learning his end of the game as he is of mastering theirs. He must be prepared to give twenty-four hours a day to his work when a picture has to be finished on schedule, and then to have very little work to occupy him until the next production is started. He will be in an inherently more speculative business than the one from which he came, a business in which fundamental adjustments are taking place, in which he must take the same risks as others and in which there is no room for people who become irritable under stress or who are incapable of concentrating a maximum of energy on the job when it is needed. The

choice is largely a matter of temperament, and, of course, the element of luck plays a part, as in all business situations. Most men, without doubt, are better off under the moderate stresses of the broadcasting business: a few, who possess unusual adaptive qualities, and the knack of fitting into organizations without a long process of assimilation, may acquire a fair competence in a few years in the movies.

It will now be instructive to follow the career, through somewhat similar mutations, of a young man who differs from John principally in his early training and the influence this exerts on his later course. Call him Tom, for easy reference, and assume that he is backed with enough money to see him through a first-rate electrical engineering course, with a degree of specialization in radio and audio principles, acoustics, telephony, and the like.

In the first place, quite aside from the expense of his education, Tom is out a sizable sum before he gets started. His engineering training and the academic

as it turned out, my teachers were the best I could have chosen, had I been gifted with prescience when I embarked on my academic career fifteen years ago. Some of my most valued colleagues are of the John type rather than the Tom type, and I have witnessed the phenomenal ascension of several of the Johns to high places. I emphatically do not believe in a college education for literary artists, for example. Nevertheless, when it comes to a technical career, the Toms, we are bound to recognize, have the inside track, and I have devoted this much space to that phase of the subject because so many young men do not comprehend this fact until it is too late.

Tom's job is usually arranged for some months before the end of his university career. Very likely he becomes a student engineer in one of the large communication companies. A committee scrutinizes his college record, references, and photograph, and, after consulting Tom's preferences, places him at a salary of about \$150 a month in one department after another, the usual period in each division

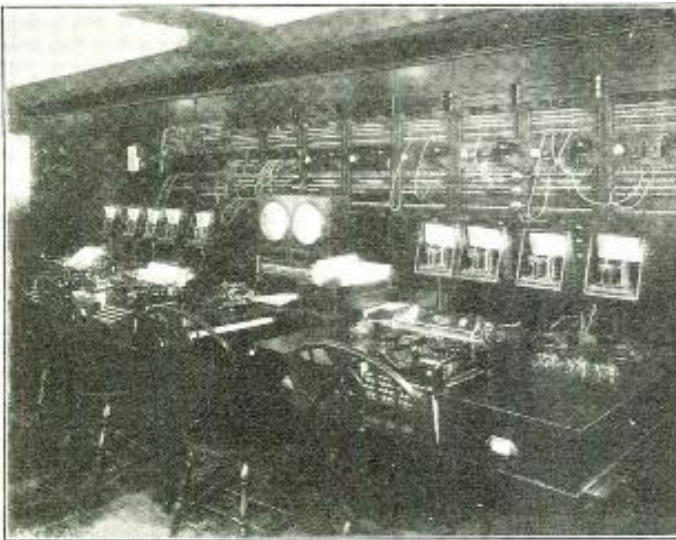

A TYPICAL CONTROL ROOM AT AN N. B. C. STUDIO, SHOWING CONTROL PANELS FOR MONITORING "CHAIN" PROGRAMS

education which precedes it requires five years, so that where John began his business career at the age of eighteen Tom must wait until he is twenty-three before money begins to come in. Allowing an average income of \$2,000 a year, this involves a sacrifice of \$10,000 on Tom's part. Nevertheless, even disregarding the personal satisfactions which may be the most valuable product of his education, Tom is likely to catch up with that handicap and to pass John in the race, other factors of course being assumed equal. In other words, one must advise young men who intend to follow technical pursuits to acquire a first-rate technical education if they can. Personally, I have no bias in the matter; my own technical training was moderate in scope; although,

being three months. He may proceed in this way for several years, until the natural flow of men upwards makes a place for him in some branch of the work for which he has shown aptitude. He is then likely to earn \$200-\$250 a month. The above figures are based on residence in a large city. If the job is in a small town, with perhaps a 30-50 per cent differential in living expenses, the salary will be less.

It is impossible to consider at length all the branches of engineering which Tom may take up. He may become a laboratory worker, living a relatively sheltered life, free from pressure to produce results in a hurry, and able to enjoy the unity of mind which comes from devoting one's thoughts to a single set of problems and doing a thorough job. If so, his income

is likely to be relatively low, because it is a rule in business that if one's work is enjoyable or easy one must pay for one's pleasure. He may become a design engineer, turning out plans for, say, radio receivers. If so, his success depends on the money-making capacity of his ideas. If they are good, at the age of thirty or thirty-five his income may be \$10,000 a year with a company of moderate size, and perhaps twenty-five per cent less in a very large corporation offering greater security of tenure. Tom may become a production engineer, who acts as a link between the sales force, with their unremitting pressure for deliveries, and the factory forces. Or, he may turn into an operating engineer, who devotes his energies to keeping the equipment going after other men have created it, and, from his intimate knowledge of what will be required of the machines when they get out of the factory, to telling the design engineers what they should build next, if they can. As operating engineer in a broadcasting system, for example, he may lay out routes for inter-station connection, determine transmission levels and frequency bands, work on the elimination of cross-talk, or the variation of transmission conditions with temperature, or protection of lines against lightning and storms, or any one of the multifarious problems which arise in such a system.

At a certain point in Tom's career his administrative ability may become more valuable, from the standpoint of income, than his grasp of specific technical problems. As one prominent engineering executive puts it, it isn't what you do, it's what you get done. There is more than a touch of cynicism in this aphorism, but it is a sober truth. Modern industry is almost incredibly complicated, and the man who can keep an army of technicians working together performs perhaps the most valuable function in the system. As specialization increases his gift of integration becomes more and more valuable. If Tom has that gift, there is no reason why his income should not continue to grow—he may be good for \$20,000 a year, say, when he is forty, or three times that amount with luck, for generally he is playing the stock market by this time. But he must beware of losing his grasp on the technical foundations. He need not know where the wires run on all the terminal boards, but he must know the salient weaknesses (even more than the strong points) of the equipment which is built or operated under his jurisdiction, and he must know the strength and weaknesses of his men just as thoroughly. In other words, an engineering executive is not a man who coordinates a lot of things he knows nothing about, but an engineer who coordinates a lot of things about which he knows the salient facts.



The RE-29-- Part Two

*Presenting Complete Constructional Details
of the Receiver, Audio Amplifier and Power Supply*

By R. E. LACAULT

EXTREME sensitivity features the RE-29, with every protection afforded for high selectivity. The six tubes are efficiently used. Three are screen grid, three are 201A. The filaments of these are battery-heated, but the plate voltage and current will be obtained from an a.c.-operated power-pack. As the 6-tube design includes one audio stage, the power pack contains the other, which is a 210 push-pull.

The six tubes constitute the most sensitive super-heterodyne receiver I have ever tuned, and this height of receptivity is due to the use of screen-grid tubes with proper load impedances, in conjunction with my system of modulation.

The receiver is built on a baseboard 25½" x 12¼" of wood that will not warp. With a square and rule draw a line right in the center of the board from front to back. Then draw another line 1½" to the left of the center line. Last of all, draw another line ¼" away from the front edge of the baseboard. Next place two blocks or legs in the back corner to raise the baseboard so that the surface is 1" above the bottom of the cabinet.

The thickness of the blocks or legs in the back depends, of course, upon the

THE theory and circuit diagrams of Mr. Lacault's six-tube receiver, the RE-29, were presented in the June issue. The present article gives detailed information on actual construction as well as full data on the power pack designed for use with this receiver.

Mr. Lacault died just after completing the article. He left also a sketch and some information on constants for an external automatic volume control to be used with the installation. This control is described in the addendum to the present article.

thickness of the baseboard. Next mark all the aluminum shields for drilling according to the templates which are furnished with the official set of blueprints. The blueprints may be placed over the various shield pieces and the holes punched with a sharp tool or regular punch. Then drill each piece of aluminum separately by placing a board underneath and using a sharp drill so that the holes are drilled straight.

Next place the bottoms of the shields

on the baseboard so that the left edges of the front and back shields are exactly on the line drawn ¼" to the left of the center line on the baseboard. At the same time the front edge of the forward shield should be exactly on the line drawn ¼" away from the front edge of the baseboard.

The right-hand shield is lined up on the front line and against the others as shown in the pictures. The shields are held in place by screwing down the coil bases and the sockets. These bases are raised above the shield with two spacers furnished with the coil, and once these are screwed down they hold the bottoms of the shields in place.

When mounting the coil bases, it is important to note the position of the white holes into which the coil is plugged. One hole is in the center of the base, while the three others are offset. It is essential that these bases be mounted in the right way.

Next, mount the other apparatus (on the left side of the baseboard) and drill right through the baseboard. These holes are used for the wiring which is made under the baseboard. Use a ¼" drill to drill the wiring holes in the shields and the baseboard.

To support the tube shields covering the shield-grid tubes it is necessary to modify three sockets. The easiest way is to proceed as follows:

Countersink the mounting holes so as

FIG. 1. THE UNDER SIDE OF THE BASEBOARD SHOWS THE WIRING OF THE SET. THE TWO WOODEN BLOCKS ATTACHED TO THE BASEBOARD ALLOW THE PLACEMENT OF WIRING UNDERNEATH

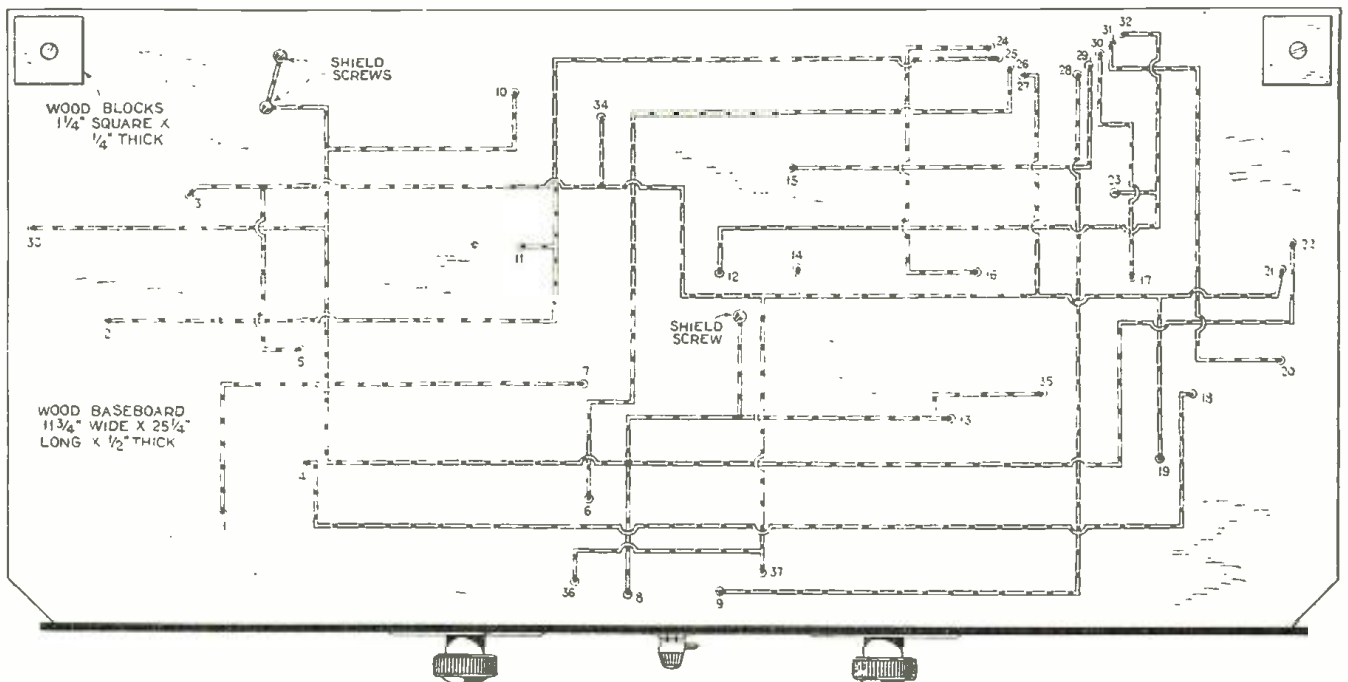

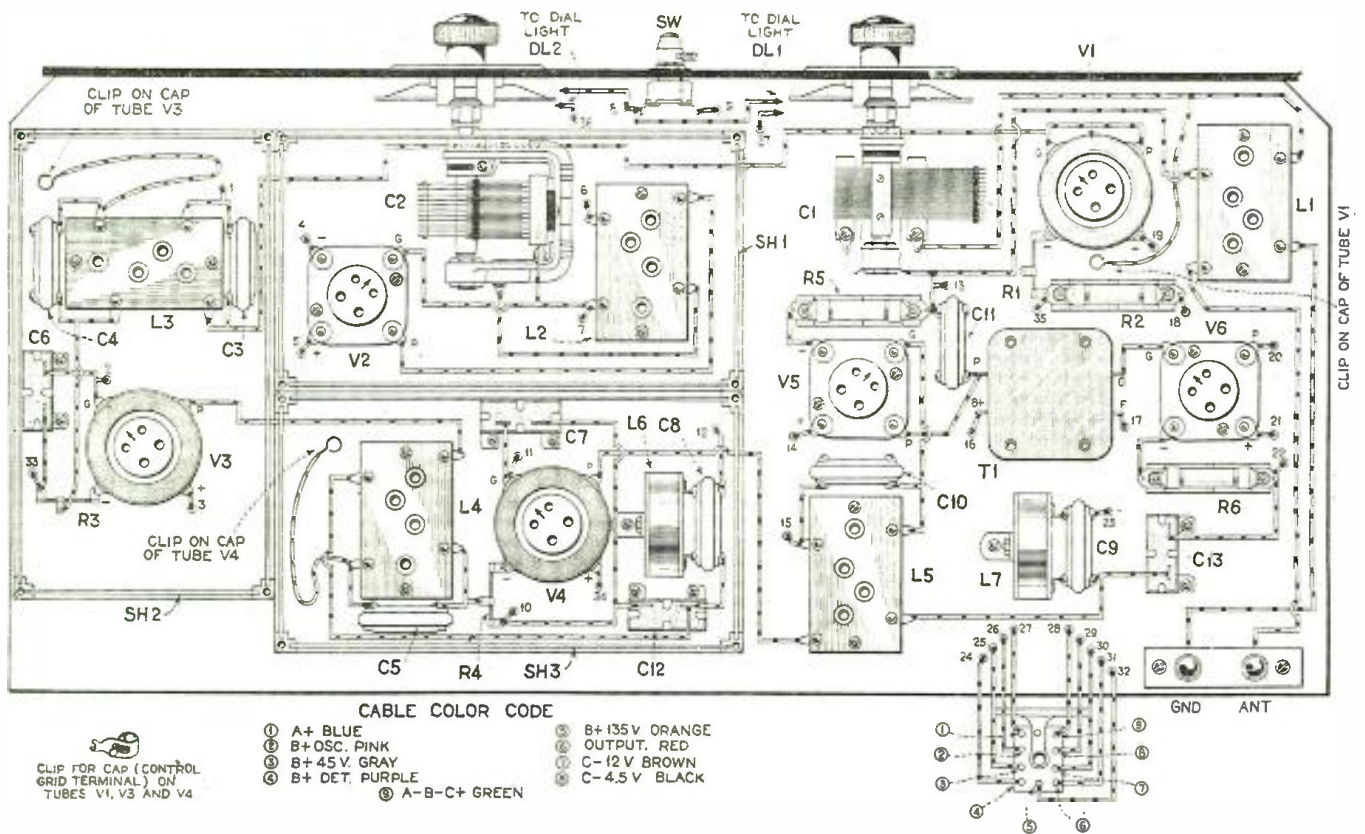
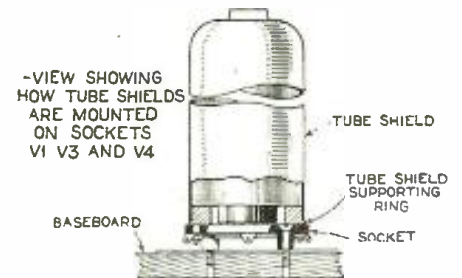

FIG. 2. THE POSITIONS OF ALL THE APPARATUS IN THE SET ARE SHOWN IN THIS ILLUSTRATION. FIGS. 1 AND 2 CAN BE USED FOR WIRING THE SET, AFTER THE APPARATUS HAS ALL BEEN MOUNTED

FIG. 3. THREE OF THE SOCKETS ARE MODIFIED SO THAT THE TUBE SHIELDS FIT PROPERLY. THE METHOD OF FASTENING THE SUPPORTING RINGS IS SHOWN HERE



to use a flat-head machine screw. Then remove the thumbscrews and nuts which are holding the floating part of the socket. Once the screws are removed, be careful not to turn the center part of the socket, since each blade must remain in its original position.

Then place two No. 6/32 flat-head brass machine screws in the mounting holes in the baseboard, and place the bakelite insulating ring over the socket after the four nuts have been removed from the threaded studs. These studs take the place of the screws and nuts which originally held the socket together. After the four brass nuts have been placed back on the studs, the socket is again assembled but with a bakelite ring around the floating part. On each one of the rings you will notice that one of the studs shows through the bakelite on the rim. This particular stud should be placed so that it holds the minus "A" terminal on the socket. This arrangement is provided to ground the tube shields to the minus "A" when they are slipped over the tube.

If the insulating rings you obtain do not have the stud showing through the bakelite, merely solder a wire to the bottom of the tube shield and fasten the other end of the wire to the aluminum shield under a screw or nut.

The templates for the National type E dials are furnished with the dials. The panel is mounted last of all and is adjusted as follows:

Lift up the set and let it rest on the

back shield so that the front of the set is flat and on top. Unscrew the set-screw of the right-hand dial and drop the panel so that the right condenser shaft fits in the dial hole.

Straighten the lower edge of the panel with the baseboard and with a sharp tool punch the edge of the board through the three mounting holes. In this way one avoids the binding of the right dial.

After all the parts are fastened on the board you may start the wiring. The wire (rubber covered) is looped, cut and soldered to the various lugs. This is an easy and rapid way of wiring.

When connecting the various wires to the fixed part of the cable plug which is fastened on the baseboard it is best to tin the wires. It is then easy to heat the small tubes into which the wire slips.

As you solder the wires to the plug, make sure that there are no strands of wire touching the next plug.

One must be careful, however, where the wires pass through holes in the shields. Once all the wiring on the baseboard is done, the partitions of the shields may be installed and the wires passed through the holes which have been drilled previously. Begin with those connections right behind the panel and work toward the back. It is easier to solder the connections. The corner posts of the aluminum shields are fastened with long machine screws through the baseboard. The head of one of the screws holding a corner post of each shield should be soldered to the minus "A" wire so as to

ground each shield. The panel supports only the two dials and the switch.

A good precaution is to check the wiring once it is completed and, leaving the minus of the "A" battery connected to the minus terminal, touch all the other wires in the cable to make sure that no tube lights. If one does light, there is something wrong in the wiring.

If everything tests satisfactorily, connect the power unit and adjust the voltages. An accurate high resistance voltmeter will show exactly what you get and we urge you to use one.

Some tubes work better with a little more plate and grid voltage, others with less. In other words, the set has to be adjusted for the tubes in use.

Now for a discussion of the power pack, the diagrams and photographs of which are published herewith.

Two 281 tubes are used, for full-wave, high-power rectifiers, the power transformer supplying the necessary a.c. voltage, and the potential-dividing network at the output, suitably by-passed, affording accessible rectified voltages of C—12, C—4½, B+Det., B+45, B+Osc. and B+135. The full 350 volts are applied only to plates of the pair of 210 tubes used in push-pull, hence no outlet post

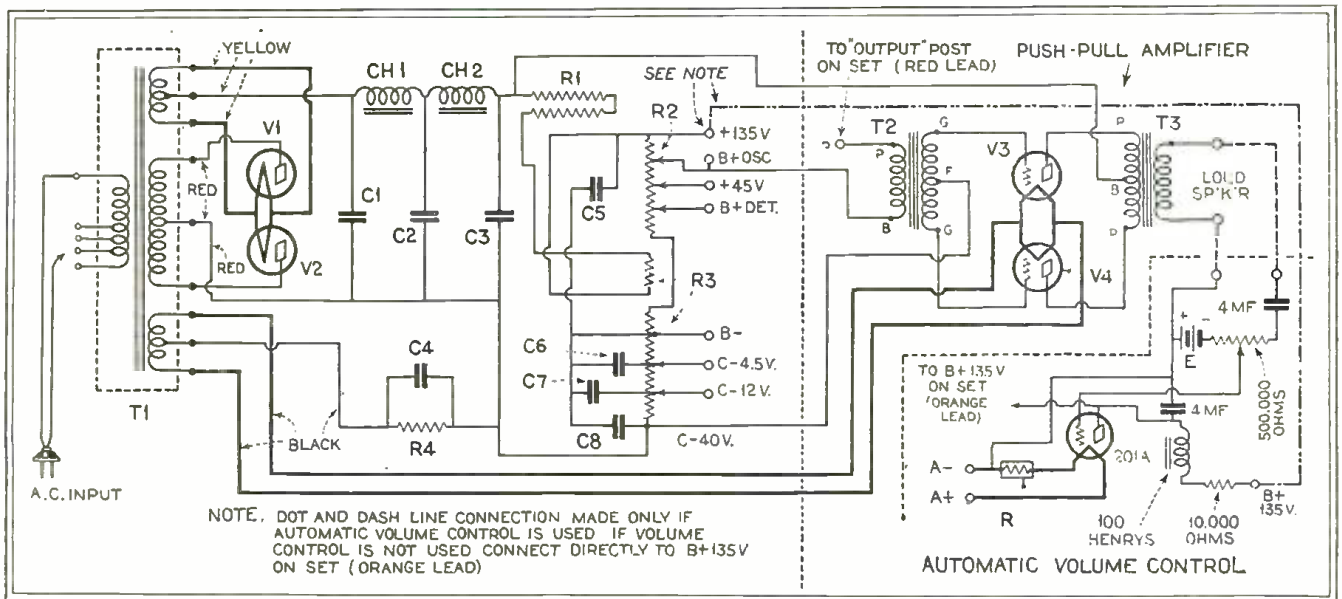

FIG. 4. THE SCHEMATIC DIAGRAM OF THE POWER UNIT, THE AMPLIFIER AND THE AUTOMATIC VOLUME CONTROL THAT THE AUTHOR SUGGESTED IN HIS NOTES ARE SHOWN HERE

is necessary for this latter voltage. Most of the accessible voltages are adjustable by sliders on the resistors.

The power transformer is so heavy that wood screws cannot be relied on. Hence, for mounting this transformer four large holes are drilled through the board and the transformer is mounted by means of bolts. If flat-head bolts are used, the holes on the bottom side should be countersunk. If any other type of bolt is used the holes should be sunk on the under side so that the heads of the bolts come below the surface of the board.

The baseboard for the power pack is

25 1/4" long and 12" wide; which allows ample room for all the parts without any crowding. This not only permits easy access when wiring, but it facilitates circulation of air for cooling the parts.

The actual layout of parts for the "B" battery eliminator and push-pull power amplifier is shown in Figs. 5 and 6. The power supply portion of the unit is shown at the right, and the push-pull amplifier is shown at the left. Some few parts, like small by-pass condensers, are not shown in the illustrations, although they are in the diagrams, and of course such parts

FIG. 5. VIEWED FROM ABOVE, THE POWER UNIT FOR THE RE-29 SHOWS THE EXTRA WIDE SPACING THAT WAS LEFT FOR VENTILATION. THE PUSH-PULL AMPLIFIER IS ON THE LEFT AND THE "B" POWER SUPPLY ON THE RIGHT

should be included in the circuit.

The power transformer is an Amertran PF250. It is provided with five leads on the primary side. One lead is on the grounded side of the line, and the four others are for input voltages of 100, 110, 115, and 120 volts. The lead suitable for the voltage on the line is selected. Usually it is not necessary to provide for switching from one to the other because at any one place the voltage remains fairly constant during service.

The two leads of the plug-in cord should be securely connected to the proper terminals on the transformer and soldered. Then they should be wrapped separately with several layers of friction tape and finally taped together.

In building the power pack and push-pull amplifier the following procedure is recommended:

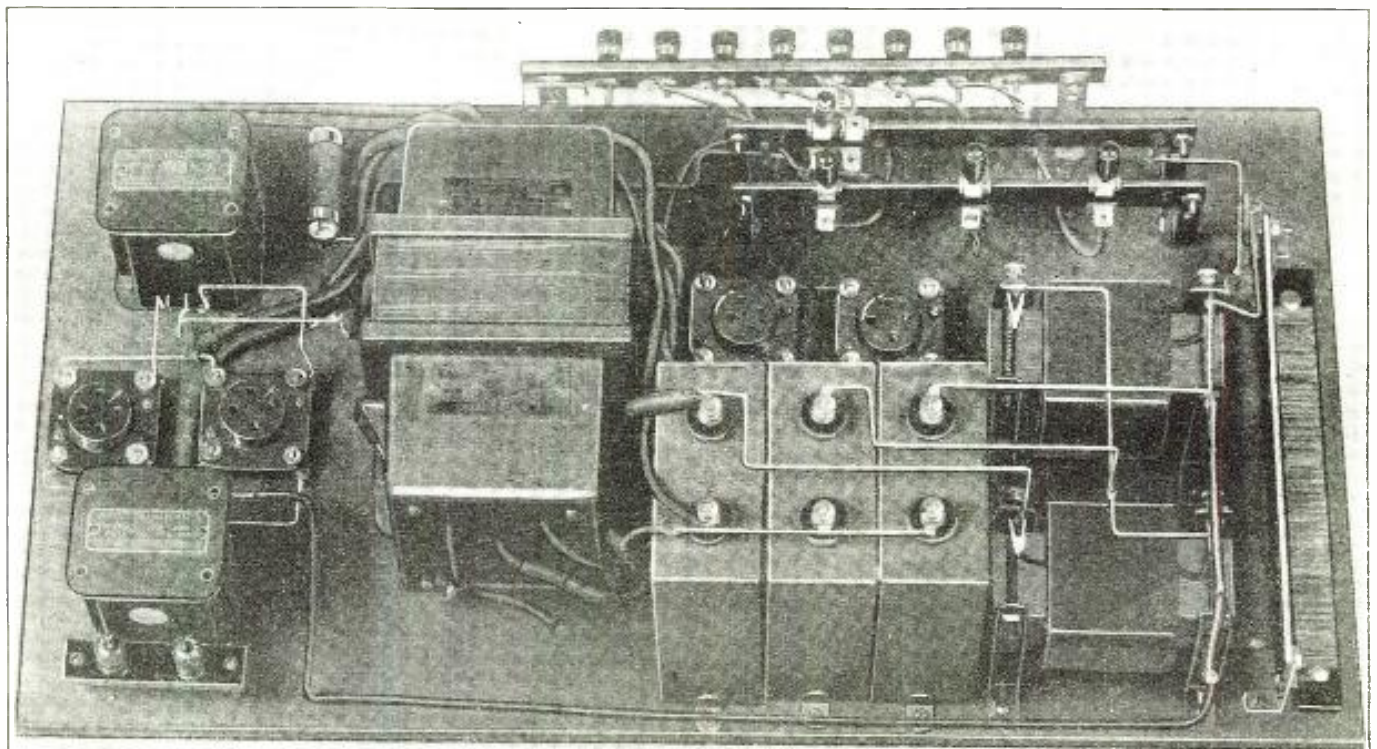

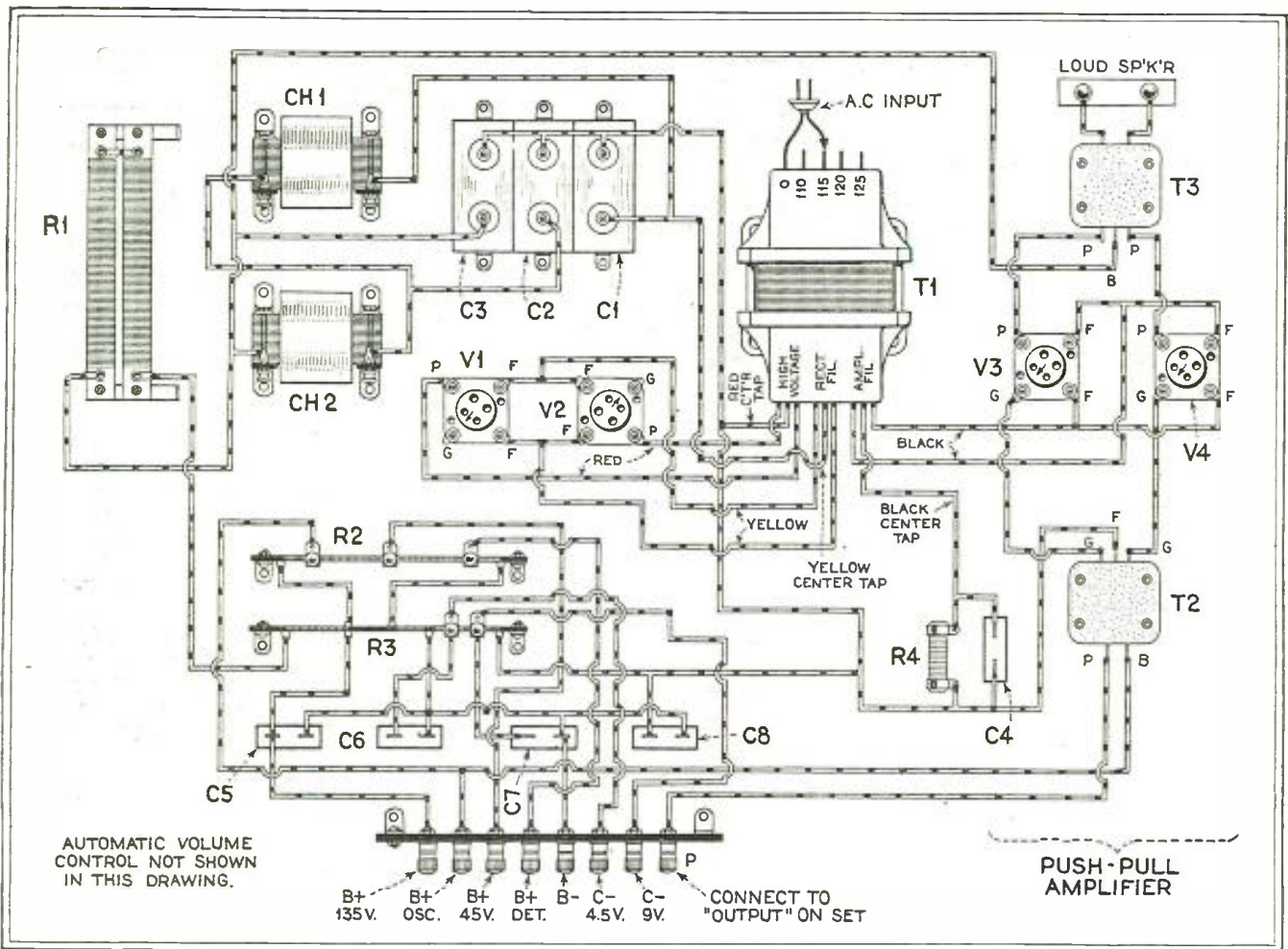

FIG. 6. THE LAYOUT OF THE PARTS IN THE POWER UNIT AND AMPLIFIER FACILITATES THE CONSTRUCTION AND WIRING OF THE UNIT. SOCKETS V1 AND V2 ARE FOR THE UN281 RECTIFIERS; V3 AND V4 ARE THE AMPLIFIER SOCKETS

First, place the parts on the board in the proper positions without fastening any down. Mark the position of each with a pencil and locate the holes for the mounting screws. Do this accurately so that all the holes may be drilled at once while nothing is on the board. Remove all the parts, and drill.

Next mount the power transformer. Do not connect anything to the primary leads of the transformer. When the transformer has been bolted down mount the two sockets for the rectifier tubes. They will be almost in the center of the board.

When this has been done, connect the filament leads from the transformer to these sockets. There will be three heavy yellow leads on the transformer. The outside two of these go to the F terminals of the two sockets. Connect the sockets in parallel with heavy leads, such as heavy bus-bar wire.

Next connect the outside red leads from the transformer to the plate terminals of the sockets, one to each. These are the high-voltage leads through which flows the alternating current to the rectifier. The two grid terminals are left blank. Avoid loose, uninsulated ends.

The next to be mounted are the three high-voltage Parvoltage condensers. They are placed to the left of the transformer, back of the sockets already mounted.

Connect the three condenser terminals farthest away from the sockets with a piece of bus-bar and then connect the

central red lead from the transformer to the same point. Then connect the central yellow lead on the transformer to the unused terminal of the condenser.

We are now ready to mount the two filter chokes. They are placed to the left of the condensers and the sockets. From the post on the first choke to which the yellow lead has been connected, run a bus-bar wire to the nearest terminal of the first choke. This choke is at the back. Insulate the wire with spaghetti. While this is not vital, it is wise.

Next, run a bus-bar wire from the unused terminal of the middle condenser to the second binding post of the first choke, and connect this lead to the first terminal of the second choke. Insulate these leads. Now run a similar (insulated) lead from the unused terminal of the third condenser to the second terminal of the second choke coil.

At this point leave the "B" battery eliminator and go to the push-pull amplifier. Mount the two sockets first. Connect the filaments in parallel and run the outside two heavy black leads from the transformer to the filament terminals.

Next mount the two push-pull audio frequency transformers, the output transformer at the back and the input in front. Mount a binding post strip, containing two posts, directly behind the rear transformer on two long single brackets. Connect up these binding posts and also the grid plate terminals on the two push-pull

(Continued on page 92)

THE reader will find it interesting to observe that practically all of the more worthwhile receivers which are being offered to them this season are available at radio dealers' in kit form. This is true of the Lacault RE-29, and naturally, where maximum satisfactory performance is to be sought it is generally recommended that no substitution of the parts listed be indulged in by the builder. In no other way can results which are on a par with those obtained by the designers be expected. The blueprints which are referred to frequently in the accompanying text are full-sized and may be obtained separately or with the official kit and for that reason are not reprinted here.

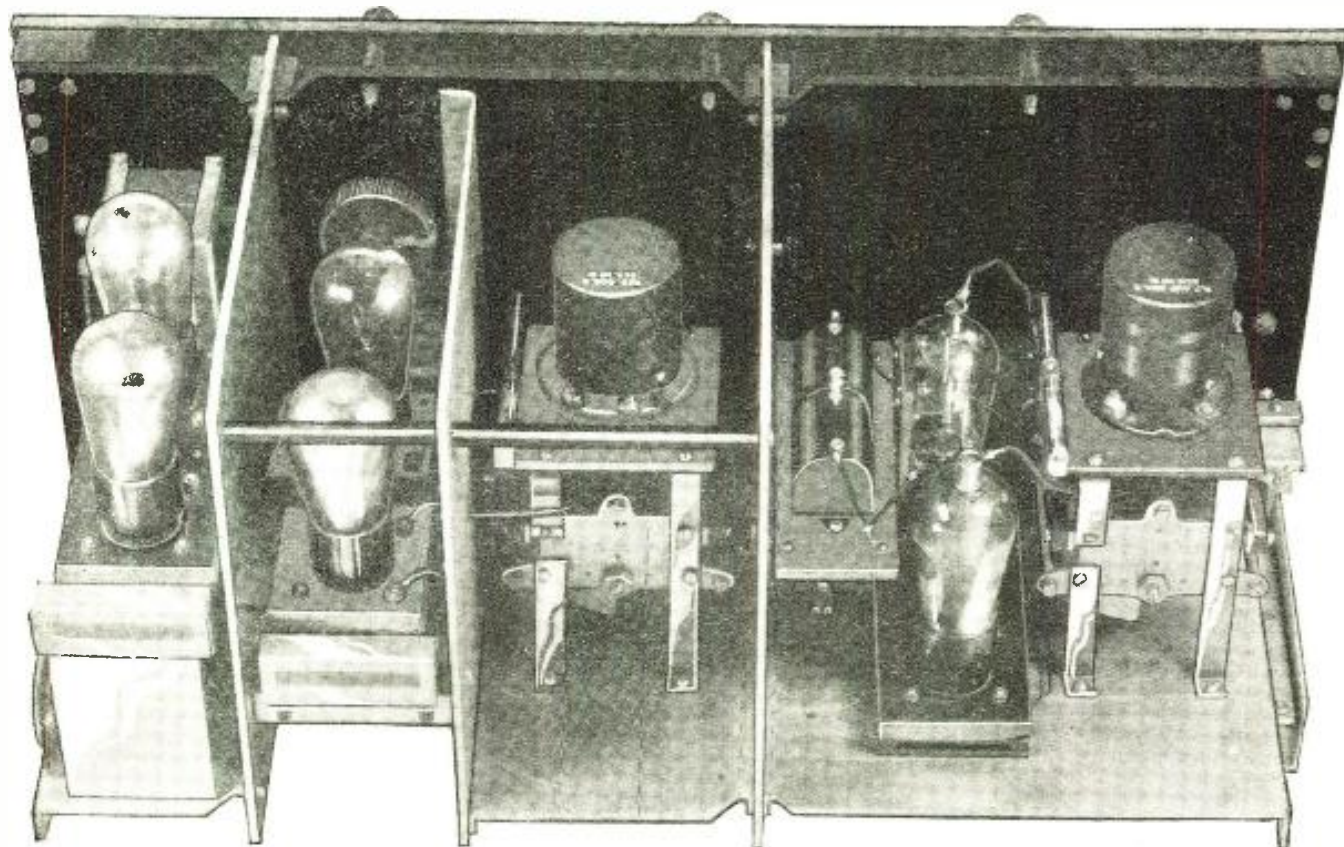

A REAR VIEW OF THE ASSEMBLED RECEIVER USED IN MR. MARSHALL'S TESTS

Some Experiments on Ultra-High Frequencies

By THOMAS A. MARSHALL

BACK in 1925, when 12 meters or thereabouts was considered the shortest wavelength on which transmission of signals could be obtained, a radio theory was advanced, perhaps as a relief to those who had ambitions to talk to Mars and other heavenly bodies, that since the waves shorter than 12 meters could not possibly be used successfully over the earth, they could be used for interplanetary communications. This supposition was offered as it appeared that these short waves would be capable of piercing our atmosphere as well as that of other planets. It was also believed that the course of the interplanetary wave on leaving the earth would be strongly influenced by the electrons coming from the sun and would be diverted directly toward the sun, where it would reach an electron density of more than 100,000 per cubic centimeter, which would cause total reflection. The wave might then be reflected toward Mars or other planets. Many prominent scientists, however, did not agree with this theory, and believed that satisfactory transmission could be obtained on these ultra-short wavelengths. They said "Time will tell."

TO the many experimenters who have been delving into the mysteries and behavior of transmission and reception on the extremely short wavelengths Mr. Marshall's observations as outlined here will be of distinct interest.

Mr. Marshall, formerly connected with the U. S. Naval Research Laboratory at Bellevue, D. C., and recently with the U. S. Battle Fleet in southern waters has, over a period of nine months made the observations which form the basis for the article presented herewith. His work in this field has undoubtedly provided him with much authoritative information and we are pleased to present to our readers his theories, together with a description of the receiver he used in his work.

From personal observations, it appears that time *has* told. The writer has just completed a long series of observations concerning actual reception at fundamental and second harmonic frequencies of signals being transmitted by a host of stations now operating on short wavelengths, the results of which seem to indicate that it is entirely practicable to utilize the band of 13 to 7.5 meters for transmission purposes on our own planet. By the use of his own type of receiver, he has received excellent signals from Washington, D. C., on wavelengths as low as 7.5 meters, at a distance of 2,000 miles.

The dotted line in Fig. 1 shows the skip distance effect as expounded by Dr. Hulbert in one of his lectures. It would indicate that a wavelength of 15 meters jumps over the earth approximately 1,400 miles and that a 10-meter wave is totally reflected. The heavy line indicates the skip distance as observed by the writer, as compared with that obtained by Dr. Hulbert in his investigations along these lines.

The data for extending Dr. Hulbert's curve were obtained by observations made over a period of nine months. There ap-

appears to be no longer any doubt that there does exist another favorable series of wavelengths below 13 meters, suitable and adaptable for long-distance signalling. From 6,600 to 23,000 kilocycles, which is the present band in use, there is a band of 16,400 kilocycles. From observations made, it appears that this band may be increased from 23,000 kilocycles to 40,000 kilocycles, which is 17,000 kilocycles in width, thus doubling the width of the high-frequency band.

Since the absorption of extremely short wavelengths is negligible in the Kennelly-Heaviside layer, and the skip distance is long, as shown in Fig. 1, strong signals should be received from stations located at great distances. The line (A) in Fig. 2 shows the possible angle of radiation from a certain type of antenna adjusted to 25 meters. The primary skip distance depends entirely on the angle of radiation and the height of the Kennelly-Heaviside layer. It is possible, by employing plane antennæ and reflectors, to concentrate the antenna radiation at an angle most advantageous for reception at a given distance. For extreme distances, it would be possible to control the radiation angle to increase the skip distance, and thus increase the signal strength from three to four times at the receiving station. The line B shows how the radiation angle may be changed so as to reach point D on the earth. Note that the 40° angle would give strong signals at C and diminish in strength toward D. Radiation angle B would skip over position C and produce strong signals at position D.

The conventional type of receiving circuit as developed in the past has been incapable of giving high amplification in the short-wave bands, due to the relatively low input impedance of the circuit and to the low L/C ratio. The low impedance is due to the relatively high grid-to-filament capacity. This may be further explained as follows: this type of circuit, due to the high inter-electrode capacity, reduces the number of grid and plate turns of inductance for a given wavelength. The high inter-electrode capacity also limits the number of turns for feedback purposes, causing the circuit to be a poor oscillator.

The receiver circuit shown diagrammatically in Fig. 3 has many advantages over the single-circuit receiver in that it is especially suitable and adaptable for reception of wavelengths down as low as 3 meters. This type of receiver functions on push-pull principles in the radio-frequency stage and detector stage, making

it possible to obtain very stable oscillations over the entire range. In fact, the receiver oscillates and performs as well at 5 meters as at 50 meters. In this circuit, the inter-electrode tube capacities are reduced: first, by use of the four-element tube which, in effect, tends to reduce the effective grid-to-plate capacity, which is effective on the input grid circuit; second, by using two split condensers having two halves which are in series across the inductance system; third, by connecting the two tubes so that each grid-to-filament capacity is across one of

providing a greater number of turns in both grid and plate circuits is the increased feedback properties which are so desirable on short wavelengths in order to obtain stable oscillations.

Another commendable feature in the push-pull radio-frequency amplifier is the perfect neutralization of feedback conditions within the tubes. This is accomplished by connecting the tubes so as to balance each other, thus providing a perfect balance regardless of the wavelength. It is not possible to accomplish a perfect balance on all bands in a single-tube cir-

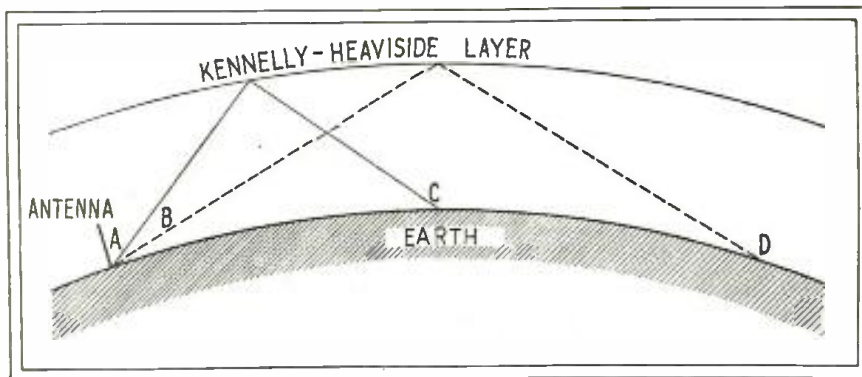

FIG. 2. ILLUSTRATING THE "SKIP-DISTANCE" EFFECT, AS EXPLAINED IN THE TEXT

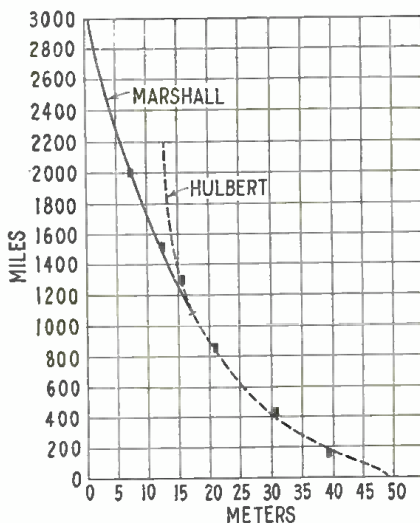

FIG. 1. A COMPARISON OF THE WAVE BANDS PREVIOUSLY ACCEPTED AS THE LOWEST PRACTICABLE FOR RADIO COMMUNICATION, WITH THOSE ON WHICH THESE EXPERIMENTS WERE CARRIED OUT

cuit. A slight feedback in a radio-frequency amplifier is desirable in order to overcome circuit resistance and increase selectivity. It will be noted that it is possible to accomplish this feature in the circuit as shown in Fig. 3. The radio-frequency stage should be balanced to a certain degree so as to reduce interaction with the detector circuit, which means no detuning effect taking place when the radio-frequency stage is tuned to resonance with the detector circuit.

The detector circuit also has another distinct advantage over the conventional single-tube circuit for voice reception, of about two to one, resulting from a change in plate current from two tubes instead of one, with a given impulse.

The push-pull circuit as shown in Fig. 3 has perfect electrical symmetry of the input circuit, which is so essential for loop reception. In a single-tube circuit, one side of the loop is connected to the grid while the other side is connected to the filament which is common to all the battery circuits, resulting in a very high

the series sections. Thus, the effective tube capacity upon the tuned circuit is halved, which in turn permits a higher L/C ratio for the short wavelengths and reduces the grid conductance, thereby increasing the amplification many fold. Due to the foregoing reasons, the circuit permits more turns of inductance for the plate and grid circuits at a given wavelength. The increased number of turns increases the input impedance, which increases the signal voltage, thus increasing the signal strength. Another feature in

PLUG-IN COILS USED BY THE AUTHOR

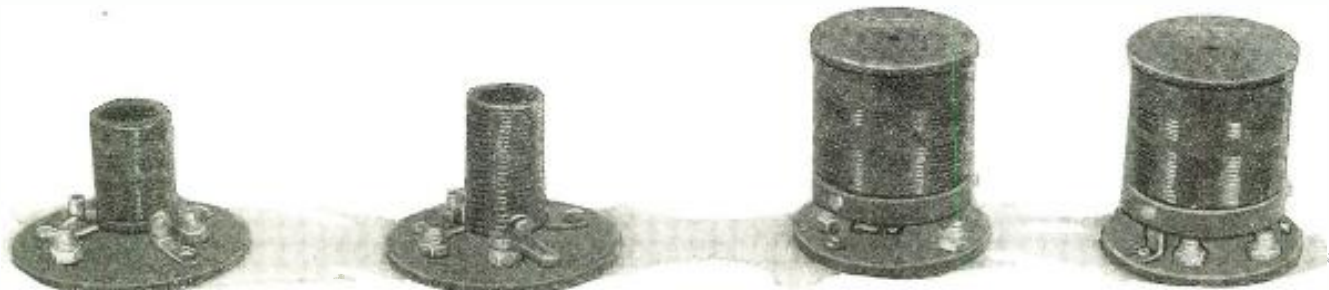

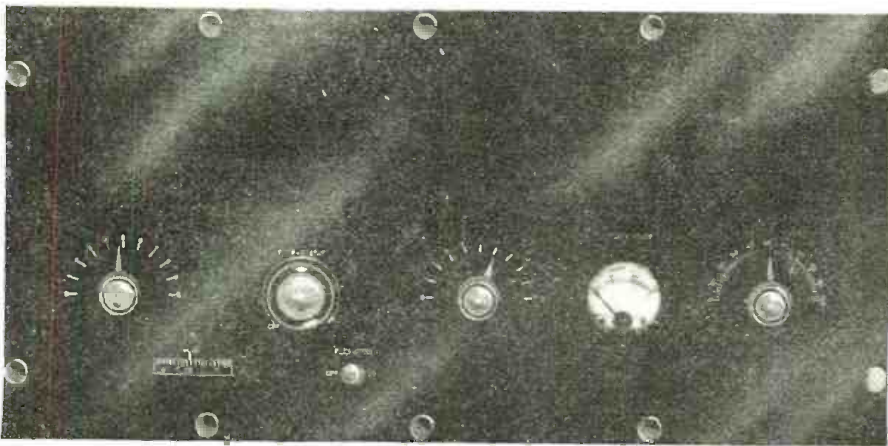

A PANEL VIEW OF THE COMPLETED RECEIVER

ground capacity. This causes dissymmetry in the electrical properties of the loop system. The unbalanced condition of such a loop system brings about a certain degree of antenna effect, causing the zone of silence or minimum signal not to be present while rotating the loop. In order to minimize interference, it is essential that the loop have zero minimum signal.

Taking up in detail a description of the circuit shown schematically in Fig. 3, L and L1 are wound on a bakelite form and have fixed relationship to one another. C and C6 are Cardwell .00025 mfd. variable condensers having the stators

split; which is accomplished by cutting the bus bar connections at the center. C1, C2, C7 and V8 are .0001 mfd. condensers.

C10 and C11 are plates 1/2 inch in diameter and are arranged so as to be variable in capacity. These condensers should be permanently secured between the tubes and have the top plates soldered to a brass screw which may be turned by using a wooden screwdriver while making final adjustments. C3 is a 1 mfd. condenser. R1 and R2 are 1 megohm grid leaks. R3 is a 190-ohm variable rheostat.

L2 and L3 are secured to the inside of the shield and are mounted horizontally about 3 1/2 inches from coils L and L1. L4 is mounted vertically and directly underneath the junction of L2 and L3. C4 and C5 are 30 mmfds. each. L5 is the tickler coil and is coupled to L6. Both coils are wound on a bakelite form with fixed relationship to one another. L2, L3, L4 and L7 are Sampson 250 millihenry radio-frequency choke coils. R4 and R5 are 1/2 megohm grid leaks. R7 is a 400-ohm potentiometer. R6 is a 100,000-ohm variable resistor. C9 is a 2 mfd. condenser. A and A1 are 5:1 ratio audio transformers.

The shields are made of 3/16-inch aluminum in order to reduce microphonic noise. The tubes and coils should be arranged symmetrically as shown in the diagram. All battery leads should extend directly through the aluminum subpanel. The audio stages should be shielded from the other circuits, as shown.

After the circuit has been placed in commission, the radio frequency stage should be detuned and the detector stage set into oscillations by varying R6, which should be set at a point where the detector circuit is just barely oscillating. R7 should be adjusted until the detector will go in and out of oscillation without "hangover" effect. This will be observed by varying R6, which controls regeneration in the detector circuit. The radio-frequency stage should be brought near

(Continued on page 82)

FIG. 3
CIRCUIT DIAGRAM, SHOWING THE
PUSH-PULL TUNER CIRCUITS AND TWO-
STAGE AUDIO CHANNEL

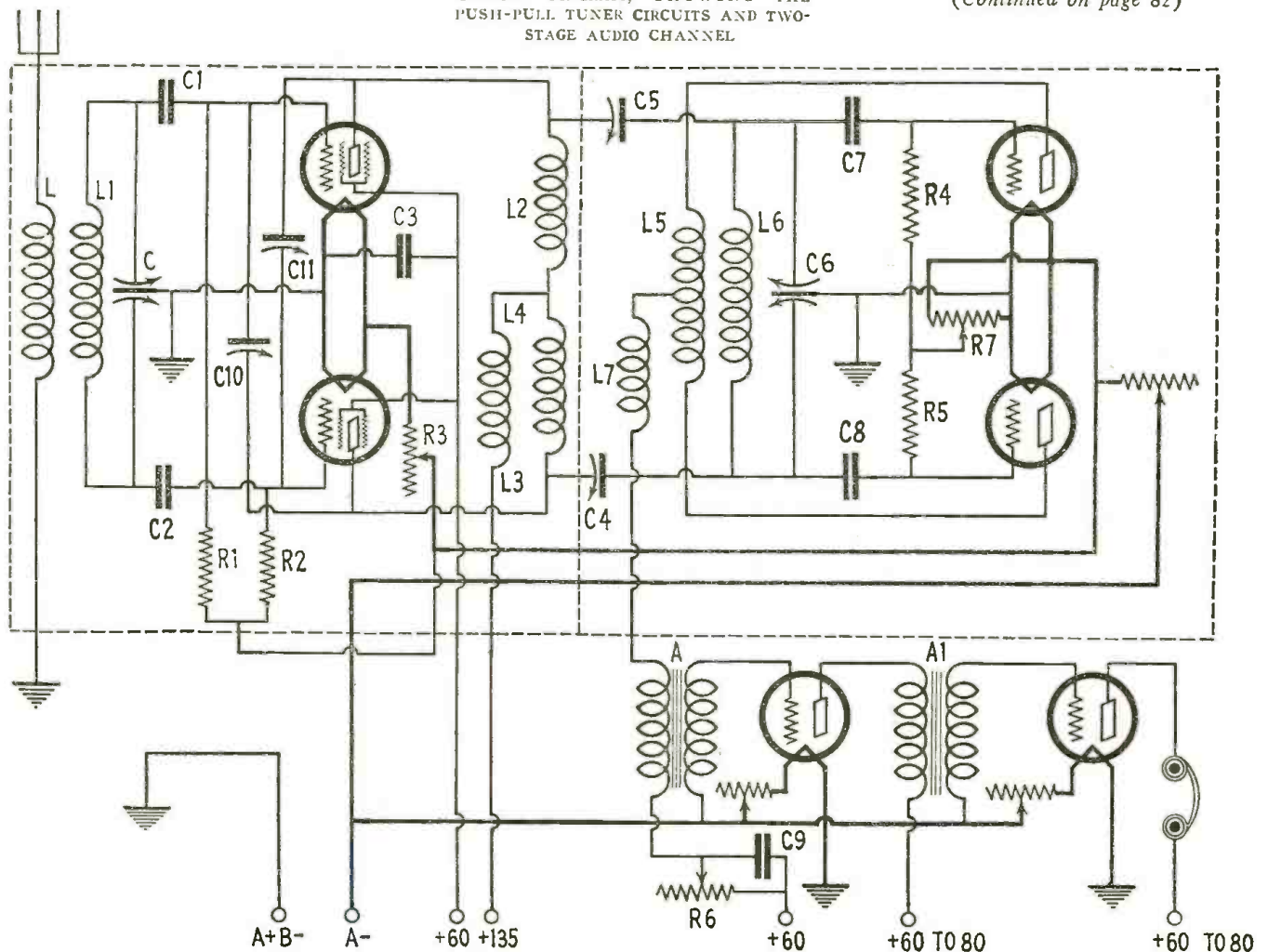

The New Silver Radio Receiver

Employing Seven Tubes, Four of Which Are A. C. Screen-Grid

By MCMURDO SILVER

PRESENT indications are that radio receiver design trends will have undergone more radical changes between the time of the June R.M.A. Trade Show and the opening of the fall season this year than in any prior year since the popularization of the neutrodyne and t.r.f. types of radio receivers.

Those familiar with broadcast receiver design are aware of the fact that for the past four or five radio seasons an overwhelmingly large proportion of all broadcast receiver production has been of the tuned radio frequency neutrodyne type, employing two or three stages of tuned r.f. amplification (three or four tuned circuits) followed by a detector and two stages of audio amplification, the second stage often of push-pull type in the more pretentious receivers of the past two seasons. Viewed in this general fashion, it is safe to say that broadcast receiver design has undergone few radical changes in these years, and is to-day recognized as having failed to keep pace with changing transmission conditions.

In 1924, the high power broadcast station transmitting programs with practically perfect fidelity throughout the musical frequency range of 50 to 5,000



THE RECEIVER, INSTALLED IN A "HIGH-BOY" CONSOLE, PROVIDES A FITTING HOUSING

cycles was almost unknown. Recently, more and more of these stations have come into operation, taxing the selectivity of the average radio receiver to an ever increasing degree. Attempts to design increasingly selective receivers along conventional lines have had the unfortunate result that, the more selective the receiver, the more are the high musical frequencies suppressed.

The difficulty of obtaining selectivity adequate for 1929 conditions without serious impairment of tone fidelity is sufficient reason in itself for the radical and widespread design changes soon to be evident. The purpose of such changes is, of course, to provide radio receivers of (1) a very high order of tone fidelity, with (2) selectivity sufficient to receive one, and only one, station at a time, (3) all electric in operation, of course, and with (4) convenience (from an installation standpoint) distinctly in advance of previous years' models. (5) at what amounts to lowered costs for the type of performance provided.

The newer design trends may be summarized as follows:

- (a) a.c. screen grid tubes as r.f. amplifiers;
- (b) use of the same type tubes as power detectors;
- (c) band selector tuning, supplementing or replacing cascade tuning;

THIS IS THE COMPLETE CIRCUIT DIAGRAM OF THE SILVER RECEIVER, IN WHICH IS INCORPORATED THE POWER SUPPLY

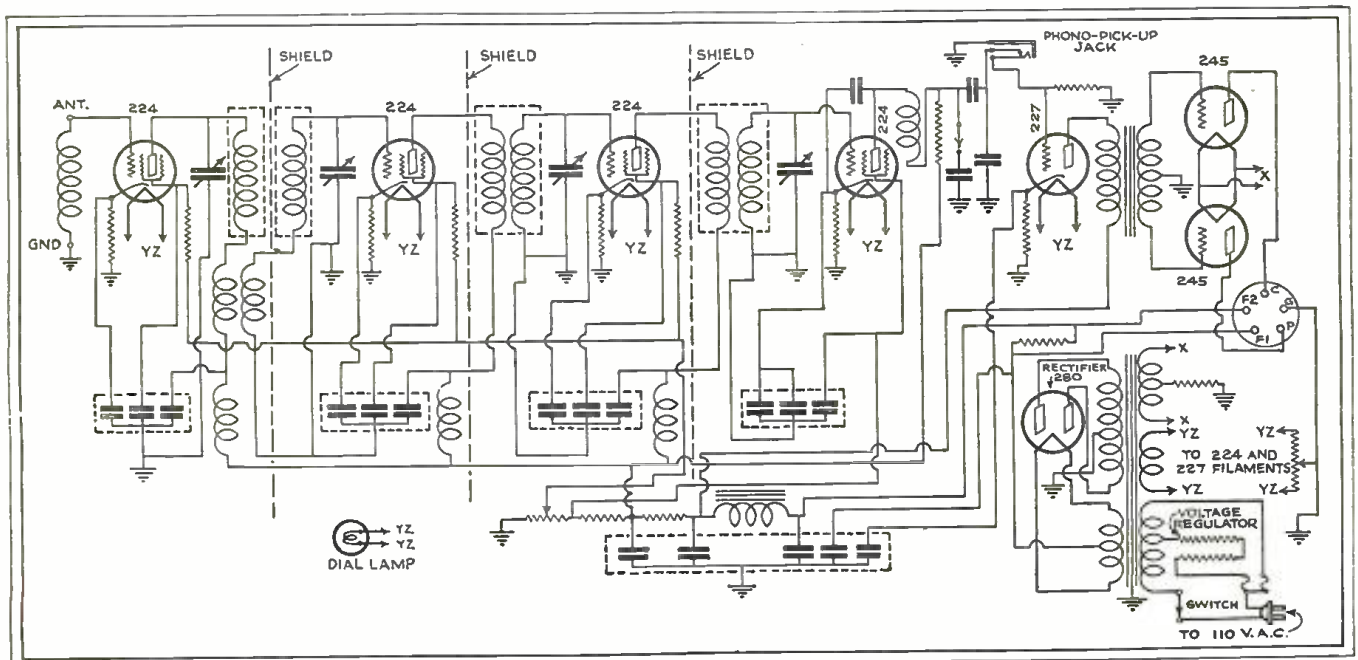

(d) elimination of the need of large antennas through increased receiver sensitivity, in order to allow for the use of self-contained signal collectors of dimensions permissible in the average apartment or small home installation;

(e) improved tone fidelity, obtained through flattened audio frequency characteristics and through preservation of high audio tones by band tuning;

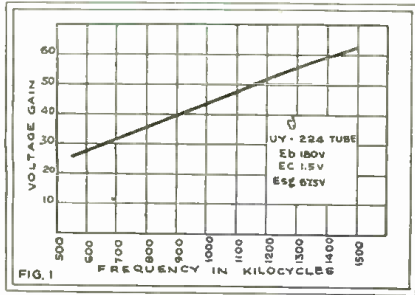

FIG. 1. A TYPICAL AMPLIFICATION CURVE FOR A SINGLE R.F. STAGE

(f) push-pull power output stages using UX-245 power tubes for adequate undistorted home volume;

(g) use of highly perfected dynamic speakers, carefully matched and baffled to respond to the full musical range of 50 to 5,000 cycles.

(h) automatic regulation of fluctuating power line voltages;

(i) reduction in selling prices on high-grade receivers, resulting from improved manufacturing processes and engineering simplifications.

One of the new receivers incorporating the features above outlined as produced by Silver-Marshall, Inc., is known as Silver Radio. Essentially the offerings of this company consist of one standard receiver chassis and loud-speaker unit which is furnished in two different models of period cabinets. As the receiver introduces many features totally new to the average radio enthusiast, the set is here described in some detail.

Silver Radio has been developed with the object of providing, in a set of low

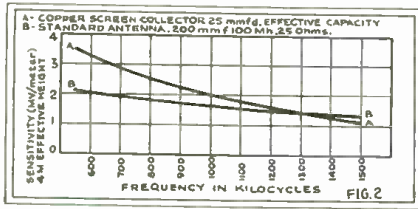

FIG. 2. THE RELATIVE EFFICIENCIES OF TWO ANTENNA SYSTEMS

cost, thoroughly simple and dependable in operation, and fully all-electric, the following specialized features:

(a) distance range limited only by prevailing atmospheric noise or static;

(b) selectivity adequate to select one, and only one, station channel at a time;

(c) reproduction of received programs with absolute tone fidelity.

The engineering features productive of these results are described in the following paragraphs.

The receiver and loud-speaker chassis,

housed in the highboy type of cabinet, are illustrated in the accompanying photographs. The receiver is seen to consist of a large, formed, die-pierced and cadmium-plated steel chassis carrying the parts of the receiver proper. At the left end of the chassis is a rectangular steel shielding case, with removable cover for access to tubes. This r.f. amplifier shield is divided into four separate compartments. In the left compartment is housed the antenna input coupler, first UY-224 a.c. screen grid r.f. tube, and one section of the four-gang tuning condenser; in the second section are housed the second r.f. amplifier and the second section of the gang condenser (these first two capacity sections are used in the band selector stage), in the third compartment from the left is housed the third screen grid r.f. amplifier with its gang condenser section, while in the fourth compartment is the screen grid detector, with its condenser section and the first audio tube.

Immediately beneath the respective sections are the inductances, condensers, and resistors diagrammed in the schematic diagram herewith. Each stage section is separately partitioned off by means of shields running the full width of chassis (shown in the schematic

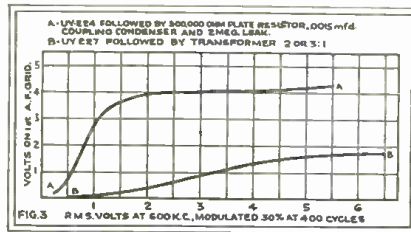

FIG. 3. THESE TWO CURVES INDICATE THE PERFORMANCE OF THE 227 AND 224 TUBES AS POWER DETECTORS

diagram as vertical dotted lines). The four-gang condenser is controlled by means of an illuminated drum dial, calibrated directly in kilocycles so that, to select stations, it is merely necessary to tune to the "telephone number" given (in kc.) in the daily newspaper for the different stations whose programs are listed. The entire r.f. end of the receiver is located in and below the large rectangular r.f. shield which covers the entire left end of the chassis. The dial is located on the exact center line.

At the right rear is a large ventilated steel case, housing an extremely large power transformer which furnishes A power—and, through the rectifier tube, B and C power—to all tubes. In front of this can, from left to right, are the two UX-245 tubes in the push-pull power stage, socket for the automatic voltage regulator, and the UX-280 rectifier tube. On the rear edge of chassis is located the phonograph pick-up jack, hum adjuster, socket for loudspeaker connecting plug, and a small panel (ordinarily covered by a metal case), upon which are mounted two pairs of fuse clips. When a fuse is placed in left clips, the voltage regulator is included in the primary circuit of power transformer and serves to hold all filament voltages constant to within 5

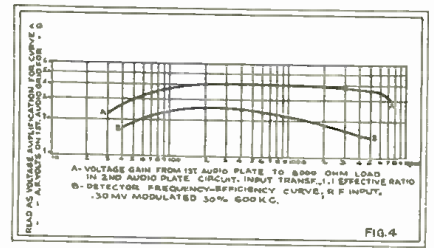

FIG. 4. CURVES A AND B, ABOVE, ARE EXPLAINED IN DETAIL IN THE TEXT

per cent throughout a line voltage range of from 90 to 130 volts.

In territories where the regulator is not required, it may be omitted by placing the fuse in the right clips. The fuse in this position closes the circuit to a primary of the power transformer designed for 110 to 120 volt, 50 to 60 cycle a.c. operation. For 25 cycles, models are made specially. The filter condenser bank, choke coils and other apparatus seen in the circuit diagram are all located beneath the metal chassis. The only external connections provided for are antenna (or self-contained screen collector), ground, loud-speaker connecting plug, and a.c. power cord, as well, of course, as jack for optional phonograph pick-up use.

Electrically, the receiver circuit is of the t.r.f. type, consisting of three stages of r.f. amplification, using UY-224 (C-324) screen grid a.c. tubes, followed by a power detector using a similar tube, and two stages of audio amplification, the first including a UY-227 tube, and the second a pair of UX-245 power tubes.

The engineering features of the receiver can be most easily understood through reference to the schematic diagram. At the extreme left are the antenna and ground binding posts. The ground connection is intended to be made to a water, steam, or gas pipe, and the antenna connection either to a small self-contained screen collector contained in the receiver cabinet, or to any other antenna that may be used.

With the normal capacity of this screen collector, the antenna choke is resonated slightly above the broadcast

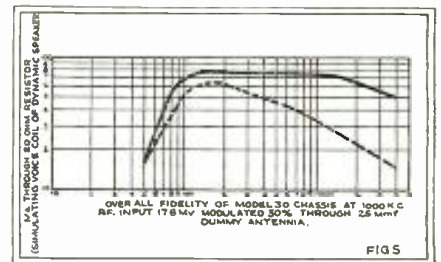

FIG. 5. CURVES SHOW THE FIDELITY OF REPRODUCTION WITH, AND WITHOUT, USE OF THE "OVERTONE SWITCH"

wave-length band to provide an input characteristic showing greatest "gain" at high wave-lengths and decreasing amplification with decreasing wave-length. This offsets an exactly opposite characteristic in the remaining r.f. amplifier stages, to provide substantially uniform gain at all waves in the range of the set. This choke feeds the first UY-224 r.f.



THE RECEIVER AND DYNAMIC SPEAKER CHASSIS, AS REMOVED FROM THE CABINET. NOTE THE COMPLETE SHIELDING OF ALL SCREEN-GRID R.F. TUBES AND CIRCUITS; ALSO THE AUTOMATIC LINE-VOLTAGE REGULATOR, FUSES, AND METHOD OF CONNECTING THE SPEAKER

AT THE RIGHT, THE SET AS HOUSED IN ITS CABINET, WITH DYNAMIC SPEAKER. THE RECEIVER IS SO SENSITIVE AS TO REQUIRE NO ANTENNA OTHER THAN A SMALL SCREEN COLLECTOR WITHIN THE CABINET

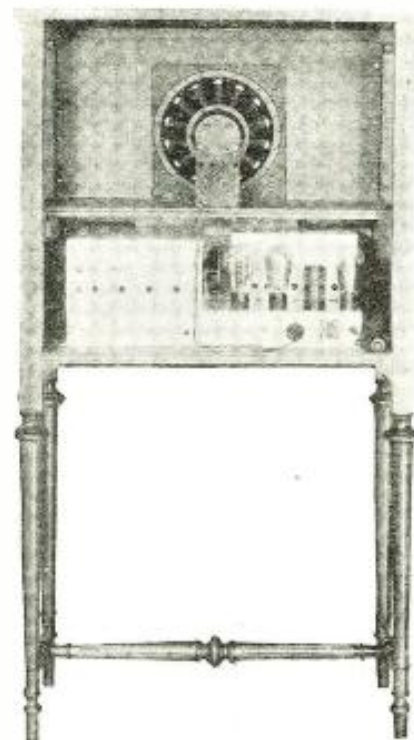

amplifier tube which, like the remaining tubes in the receiver, is provided with automatic grid bias resistor, screen grid isolation resistor and plot isolation r.f. choke. The isolation provided by these units is made effective by three .1 mfd. by-pass condensers in each stage, connected respectively from screen, lower end of r.f. plate circuit, and from cathode, to ground.

Interposed between first and second r.f. tubes is the band selector circuit, which consists essentially of two r.f. coils of identical characteristics (and identical with the secondaries of succeeding r.f. transformers), tuned by two sections of the four-gang condenser. These coils are individually shielded, and their circuits are also shielded, from each other and from stray pick-up. They are coupled to a definitely predetermined extent by means of a small bifilar coupling coil (wound with turns side by side) providing practically unity coupling. The engineer will recognize this arrangement as the so-called "critically coupled" band selector circuit, consisting of two individually tuned circuits so coupled as to provide a resonance curve with two distinct humps close together and with extremely steep sides: *i. e.*, a resonance curve substantially approaching the ideal rectangular, flat-topped conception. The band width is determined by the mutual inductance between the two tuned circuits, in this case, 1 per cent of the total inductance, which value provides a resonance curve with the flat-topped portion having a width of approximately 1 per cent of the resonant frequency. Thus, at 500 meters (600 kc.), the flat-topped portion of the selector curve is 6 kc. wide, at 300 meters (1000 kc.) it is 10 kc. broad, and at 200 meters (1500 kc.) it is 15 kc. broad. This is the most satisfactory type of adjustable band selector known today. This particular example is so designed that its r.f. gain coincides with the gain of the other two tuned r.f. stages.

The second r.f. amplifier tube, fed by the selector circuit, in turn feeds a special r.f. transformer consisting of an untuned primary and a tuned secondary. Its circuits are isolated and by-passed as are those of all the other r.f. tubes. This r.f. transformer, in turn, feeds the third r.f. tube, which, through a similar

transformer, feeds the grid circuit of the screen grid power detector.

In Fig. 1 is shown a typical amplification curve for a single r.f. stage, the figure shown applying to both the band selector stage and to the two succeeding stages (all having been designed to provide the same amplification curve shape). The amplification will be seen to vary from approximately 26 to 63 per stage throughout the broadcast band. This is about as high gain as may safely be ob-

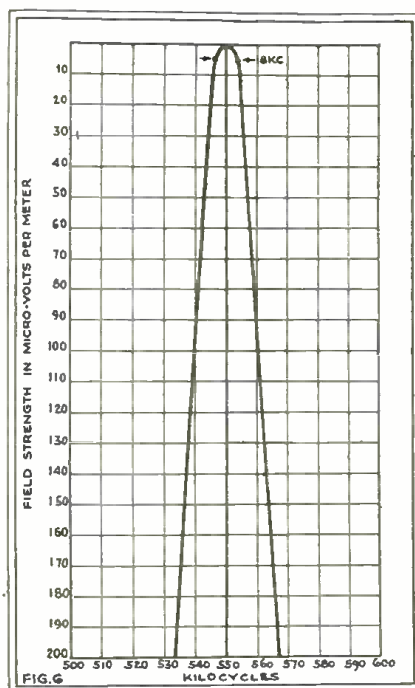

FIG. 6. SELECTIVITY OF THE RECEIVER AT 550 K.C., SHOWING THE DESIRABLE APPROACH TO A FLAT-TOP CHARACTERISTIC

tained in a multi-stage amplifier with complete stability. The amplifier is absolutely non-oscillating, each stage being so shielded that the effective feed-back couplings (except through the fortunately negligible grid-to-plate capacity of the screen grid tubes) have been eliminated.

At this point it might be well to comment upon the tendency to design r.f. amplifier stages to provide uniform amplification at all wave-lengths, in order to overcome the deficiencies of the average receiver, which amplifies more pronouncedly at short than at long waves. In this particular receiver the individual stages have not been complicated in an effort to attain this end, the antenna stage having been relied upon for such compensation. The effectiveness of this method in terms of uniform amplification at all wave-lengths is illustrated by the sensitivity curves of Fig. 2, from which the amplification ratio throughout the broadcast band will be seen to be about two to one. Volume is controlled in the r.f. amplifier by varying the screen grid potential on the three r.f. tubes by means of a tapered potentiometer which causes volume to vary in approximately equal audible units for equal increments of variation of the volume control knob.

The screen grid power detector is extremely interesting, being several times more efficient than the best detectors known heretofore. Its performance is well illustrated by the curve of Fig. 3, which shows the audio frequency signal at the grid of the first audio tube plotted against an r.f. signal, modulated 30 per cent applied at the detector grid. Two curves appear, one of UY-227 power detector, the best previously known arrangement, and the second at the screen grid power detector. The superiority of the latter is very marked, particularly considering the less-than-unity coupling provided by a resistance coupler between screen grid detector and first a.f. tube; whereas, the UY-227 detector is coupled with a transformer of 2.3:1 effective ratio.

Particular attention is called to the flattening off of the detector response curve, Fig. 3, B. This flattening has

(Continued on page 95)

An Amplifier-Power Supply for the "Beginner's Three" Receiver

By C. WALTER PALMER

IN the description of the "Beginner's Three" receiver last month, we promised to publish the constructional details of a "B" power unit and an extra audio amplifier in order to make the set suitable for loud speaker operation. The original three-tube receiver will give loud speaker volume only when powerful signals from "locals" are being received. However, when we are trying to pick up stations some distance away, it is necessary to use headphones unless extra amplification is employed.

Herewith we publish the details for making this combined "B" power unit and power amplifier. The unit has been designed in the same way as the original three-tube receiver; to be as simple as possible and to be as economical in the selection of parts necessary without sacrificing tone quality. The apparatus chosen for this set was picked out because it supplies all the conditions required in the matter of simplicity, economy and quality.

The power transformer is made with a number of low-voltage windings in order to supply current for a.c. tubes of different types as well as to supply the high voltage necessary for the "B" section. The double choke-coil unit is of the same

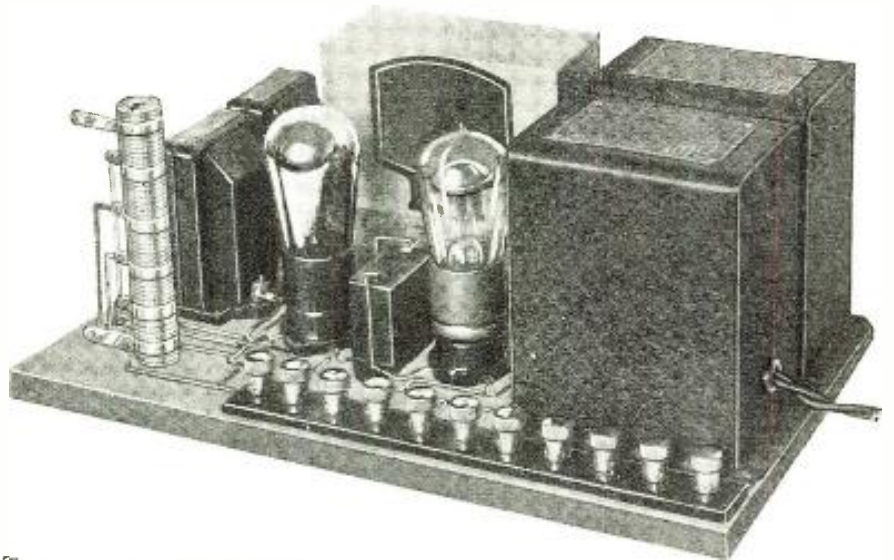

THE COMPLETED COMBINATION AMPLIFIER-POWER SUPPLY UNIT. IT SHOULD BE COMPARED WITH THE LAYOUT OF PARTS ON PAGE 64

THE CIRCUIT CONNECTIONS FOR THE AMPLIFIER-POWER SUPPLY UNIT ILLUSTRATED ABOVE ARE GIVEN HERE

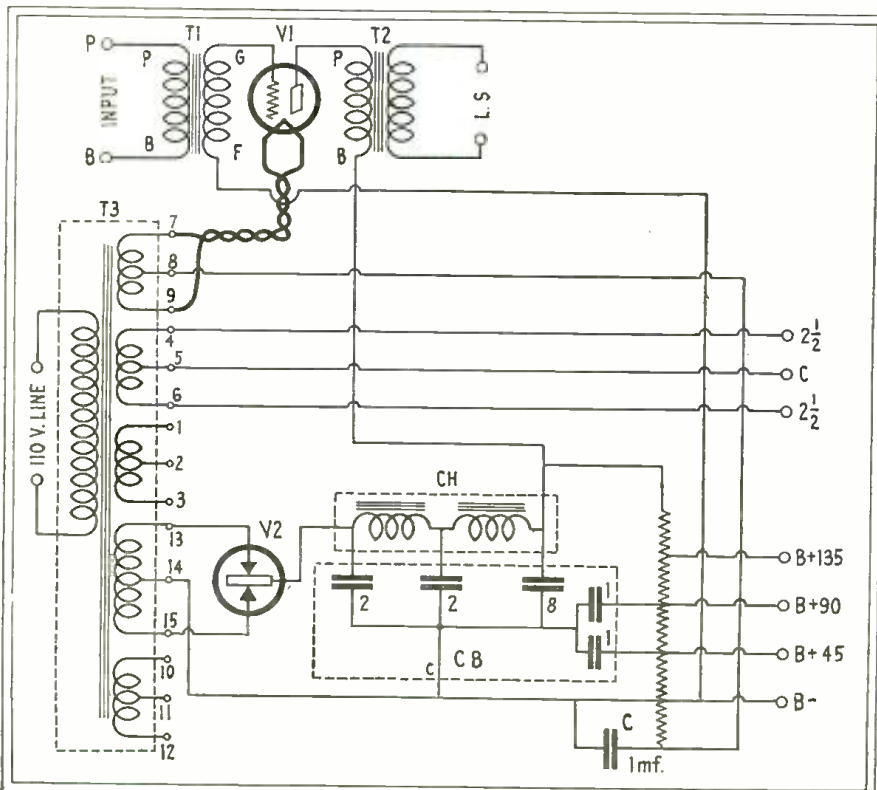

manufacture as the transformer and is designed to operate in conjunction with this power transformer. The condenser block has a sufficiently high working voltage so that no trouble will be encountered from breakdown. The voltage divider has a number of output taps which are used to supply the required "B" voltage to the three tubes of the original receiver.

While this power pack is designed particularly for use with the "Beginner's Three" it is equally applicable to any set which requires voltages up to 180 and a power amplifier of the 171 type.

We mentioned in the previous article that a storage battery could be purchased for the filament supply of the first three tubes, since this filament supply can be permanent. There are still a great number of people who prefer using batteries to "A" power units or a.c. tubes, but there are still many who feel that the convenience of the electric tubes compensates for any slight difficulty which might be encountered from hum, etc. Since our power transformer has a number of filament windings, we can use these windings for the filament supply for the three-tube receiver by making several changes in its construction. We will describe later how these changes can be made so that the '27 type tubes can be employed. When using the a.c. tubes, the "C" bias for the first audio tube can be obtained through the voltage drop in a resistor connected in the plate return. When the storage battery is used for the filament supply, it is more satisfactory to leave the "C" battery connected.

NOTE:—WOODEN BASE BOARD TO BE
14" LONG BY 7½" WIDE BY 1" THICK

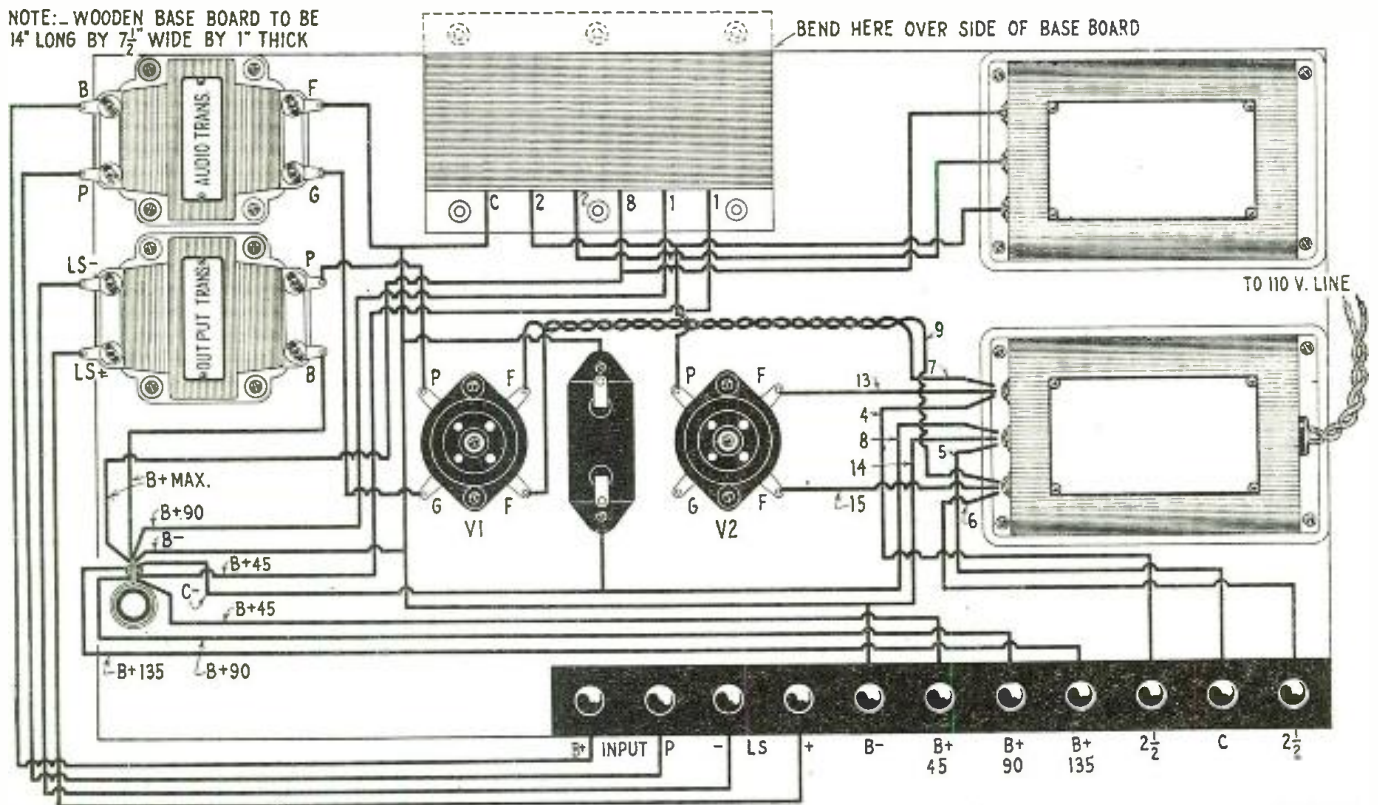

A COMPLETE PICTURE WIRING DIAGRAM
OF THE UNIT WHICH ALSO SHOWS THE
LAYOUT OF THE PARTS

The List of Parts

The apparatus required for the "B" power unit and amplifier is listed below. These parts can be changed if it is not possible to obtain them locally, but since the substitution of other parts may complicate the construction of the unit, we would suggest that the specified parts be used at all points. Transformers made by other manufacturers do not have the same filament windings or terminal specifications and of course any change here necessitates changing the layout of the parts to some extent, as well as changing the wiring.

T3—Pilot power transformer, type 398;
CH—Pilot double choke, type 395;
CB—Aerovox condenser block, type BH 420;
T2—Pilot output transformer, type 394;
R1—Electrad voltage divider;
C—Aerovox 1 mfd. by-pass condenser;
2 Pilot universal sockets, type 216;
11 X-L push-posts;
V1—Cunningham CX-371A tube;
V2—Raytheon BH rectifier tube;
1 roll of Cornish stranded Braidite;
1 strip of bakelite, 9¾ inches by 1 inch by ¼ inch;
1 baseboard, 7½ inches by 14 inches by 1 inch;
Screws, washers, etc., for mounting.

Constructing the Set

After all of the apparatus listed above has been obtained, the various parts should be laid out on the wooden baseboard. The binding-post strip is made by taking the strip of bakelite and drilling 13 holes through it. Two of the holes are placed at the extreme ends and are used for fastening the strip to the baseboard. This is done by passing wood screws through the holes and placing sev-

eral washers under the strip in order to raise it from the surface of the board. The other eleven holes which are used for mounting the binding posts should be spaced evenly over the remaining length of the bakelite strip. These binding posts are used for connecting the power unit to the set and their positions are designated in the picture diagram.

The picture diagram shows the relative positions of all of the apparatus. The size of each of the parts has been reduced slightly when compared to the size of the baseboard, so that the wiring could be shown more clearly. As will be noted, the choke coil and power transformer units are mounted at the end of the board with wood screws through their mounting holes. The condenser block is mounted next in line along the length of the board, and in order to conserve space, the mounting strip on the outside is bent down at right angles to its original position. It is then screwed into the side of the baseboard.

At the other end of the unit are the audio transformer, T1; the output transformer, T2; and the voltage divider, R1. Along the front edge of the baseboard is the binding-post strip, and in the open space between the other parts have been placed the tube sockets. The layout of the apparatus supplies the most convenient arrangement for wiring the parts and because of the positions of the tube sockets, the two tubes are protected to some extent from injury. The 1 mfd. by-pass condenser, C, is placed between the two tube sockets.

Notice that one of the filament windings on the power transformer is connected to three binding posts on the terminal strip. If a storage battery is used for the filament supply of the three tubes in the set, these three binding posts will

not be used and may be omitted if desired. These three binding posts are labeled "2½V," "C," "2½V." The terminal marked "C" is the center point of the filament winding and this terminal is connected to the negative "B" battery terminal.

To continue with the construction of the unit, after all of the parts have been screwed down in their respective positions, the various parts should be wired according to the schematic or picture diagrams on this page. The braidite wire is used for all wiring in this unit, since it is convenient to use, easy to solder and makes a very neat job. The filament wires for the power tube must be twisted in order to prevent any inductive coupling between the filament wiring and the grid or plate wires. A very annoying hum would be set up if coupling existed between these circuits. The five-volt winding which is designed to supply .8 of an ampere is used for lighting the filament of this tube. Terminals 7 and 9 on the power transformer terminal strip connect to the filaments while terminal 8 is the center point of this filament winding and is connected as shown in the diagram. The remaining windings on the power transformer consist of a 1½ volt winding, an extra 5 volt winding and the high voltage secondary. Terminals 13 and 15 are the two outer ends of this high voltage winding and they are connected to the filament terminals of the rectifier tube socket. The center terminal 14 is used as the negative terminal of the unit.

The condenser block contains 5 individual capacities. One side of each of these condensers is connected to a common terminal, which is connected to the

The Radio Forum

*A Meeting Place for Experimenter, Serviceman
and Short-Wave Enthusiast*

The Experimenter

Measuring Resistances

EVERY radio experimenter, at some time in his experience, finds it necessary to measure the values of fixed and variable resistors. A certain resistance may be required for a circuit, and although any number of variable and fixed resistors may be found in the "Junk Box," they cannot be used unless the exact resistance value is known; or unless some means is devised to find the correct point on the scale (in the case of a variable resistor). Mr. J. F. Goldman, Boston, Mass., raises the question again, in a letter addressed to this department. Mr. Goldman is building a new power-operated receiver, and intends to use resistors for the "C" bias. He has a number of variable resistors on hand, but does not know the point on the scale at which the correct resistance will be

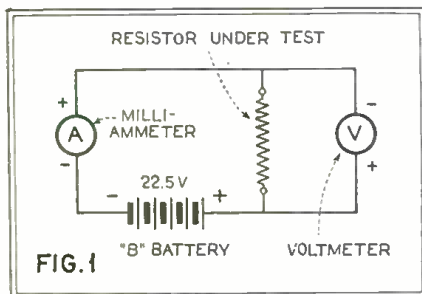

found. He inquires as to a method of determining this point.

Very few of us possess a resistance bridge, and although it is possible to make one of these units at home, it is a rather difficult task to calibrate it. Also, it would take considerable time, and for this reason it is impractical for our purpose. However, there is a simple way of measuring resistance values which uses the equipment found in almost every radio experimenter's kit. This system makes use of a voltmeter and a milliammeter in conjunction with a battery of the correct size. The voltmeter should be one of the high-resistance meters employed for testing "B" power units. The milliammeter should have a scale of about 0 to 100 milliamperes.

One of the three well-known versions of Ohm's Law states that the resistance in ohms is equal to the voltage divided by the current in amperes. If we connect our voltmeter and milliammeter to a resistor and "B" battery of about 20

volts, as shown in Fig. 1, we can use Ohm's Law to show the resistance value. Suppose we take a particular case such as required by Mr. Goldman. If the voltmeter shows that the "B" battery has a voltage of 20, and the current flowing through the milliammeter is 10 milliamperes (.01 amperes), then the resistance value is 2,000 ohms. This conclusion is reached by dividing 20 by .01. Since the current flowing through the current meter in our circuit registers thousandths of an ampere, we can change the original equation slightly and simplify the calculation. This is done by multiplying the voltage by 1,000 and dividing this figure by the current in milliamperes. In the above example, we would multiply the voltage, which is 20, by 1,000 (which equals 20,000) and then divide by 10 milliamperes, giving the same result—2,000 ohms.

Almost any value of resistance can be measured in this way by using the correct size of battery. The question may arise as to what would be done if the resistance that we are testing had such a low value that the pointer on the milliammeter moved beyond the scale. It is merely necessary, in this case, to reduce the voltage of the battery or use a smaller battery, so that the meter will remain on the scale.

In connecting the meters to the resistor and battery, as shown in Fig. 1, the connection between the milliammeter and the resistor should be left off, until we are ready to make the test. Then it should be touched lightly to the resistor, to be sure that the milliammeter is not injured because of too much current passing through it. We can also tell, from this test, if the resistor is short circuited.

Converting a D.C. Dynamic Speaker to A.C.

ANOTHER of our readers, Mr. A. Smith, of New Orleans, La., has purchased a dynamic speaker which is designed to operate from a storage battery, and after purchasing the speaker, he has received, as a gift, a new electric receiver. Naturally, he desires to use the dynamic speaker with the receiver; but the use of a battery for the field winding is impractical, for obvious reasons.

Most of the dynamic speakers which are made to operate from the A.C. lines are designed with low-voltage field wind-

ings, and are equipped with step-down transformers and dry rectifiers. The actual construction of these speakers is the same as the d.c. type except for the extra equipment required for converting the alternating current into direct current. If we add the necessary equipment to our d.c. speaker, the same results will be obtained as with the manufactured a.c. units. Fig. 2 shows the way in which the transformer and rectifier are connected to the field winding of the speaker. A trickle charger can be used quite satisfactorily if it will supply sufficient current for the field winding; or, if one of these chargers is not available, a step-down transformer having a secondary designed to supply 8 to 10 volts, and a dry rectifier of suitable size, can be connected as shown in the illustration. The size of the rectifier depends on the current required for the field winding of the speaker. Of course, this varies with different speakers, and will have to be determined for each individual case. The usual type of field winding requires a current of $\frac{1}{2}$ to $\frac{3}{4}$ of an ampere, and there are a number of dry rectifiers which will supply this current.

While we are discussing the subject of a.c. dynamic speakers, it might be well to consider one of the troubles often encountered in their use. We are referring to the objectionable hum which is sometimes heard with this type of speaker. The best way to overcome the trouble is to shunt an electrolytic condenser across the field winding in order to smooth out the fluctuations in the rectified current.

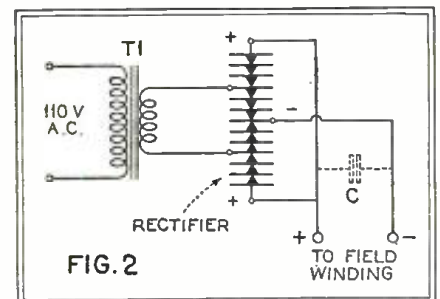

Fig. 2 shows how the condenser would be connected. Most of the "A" condensers are polarized, since they are of the electrolytic or "dry-electrolytic" types. If one of these condensers were connected incorrectly to the line, it would be injured in a very short time.

and for this reason we must be cautious. A voltmeter of the Weston, Jewell or similar types, employing a d'Arsonval movement, can be used to indicate the polarity of the rectified current, or any of the other indicating systems can be employed. The red or positive terminal of the condenser must be connected to the positive terminal of the rectifier.

The use of a transformer for supplying current to the field winding of the speaker introduces another problem. The transformer must be disconnected from the line when the set is not being used, so that it will not draw current. If we use two switches for the purpose, one for the set and one for the speaker, we will undoubtedly forget one of them at some time, and either the set or the speaker will be allowed to run for a number of hours before the mistake is discovered. In some cases, we may be able to connect the speaker to the set so that the set switch will also turn off the speaker; which can be done by connecting the primary of the step-down speaker transformer to the primary terminals of the power transformer. Since the switch is connected between transformer and line, we can easily see that this will also disconnect the transformer in the speaker from the line. If it is not possible to connect the speaker in this way (due to the construction of the set) a separate switch can be incorporated in the wire running from the set and the speaker transformer to the line, and the regular switch in the set can be disregarded.

The transformer, rectifier and condenser for the speaker can be mounted on a board or sub-panel, and in most cases it can be placed in the baffle with the speaker unit. In a few cases, of course, there will not be sufficient room in the baffle, and in this case the extra apparatus must be placed in a separate cabinet. The dry rectifiers are not all constructed in the same manner, some having the positive terminal at the extremities of the discs and others having the negative terminal at the extremities. In the first class are the Elkon and similar types, while in the second we find the Benwood-Linz. Be sure which is the proper way, as it is essential to connect the unit correctly to the speaker field winding and the filter condenser.

Amplifier for the Copper-Clad Special

ONE of the most frequently recurring questions which we have received in the past few months has been in reference to the Copper-Clad Special Short-Wave receiver which we described in our February issue. No audio amplifier was incorporated in the set, and it seems that many radio fans are not familiar with the construction of an amplifier. We are printing a diagram of a standard two-stage amplifier which may be used with almost any set. The material required for building this amplifier consists of two audio transformers, with a ratio of about 2 or 3 to 1; two amplifying tubes; two filament resistors; two tube sockets; two binding posts; a suitable panel and

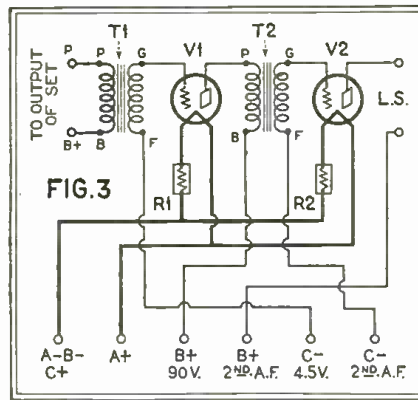

wire for connecting the various parts. The first tube, V1, should be the same type as the tubes used in the rest of the set. In other words, if 201A tubes are used for the radio frequency amplifiers or detector, a 201A or other 6-volt tube should be employed for the first amplifier. If the 199 type tube is employed in the set, the same type of tube should be employed for the first audio stage. In the second audio stage, a power tube should be used, if possible, in order to supply the best quality. If dry cells are used for the filament supply, the most practical tube for the last audio stage is the UX-120 type. If a storage battery is employed, or if a separate step-down filament transformer is used for the second stage, a power tube such as the 112A, 171A or 210 can be employed. The value of resistor R1 depends on the tube used in the first amplifier stage. Suitable filament resistors, such as Amperites or Lynch Equalizers, are available for all types of tubes, and it is necessary to insert the correct resistor into the mounting. If alternating current is used for the second audio stage, the filament circuit must be disconnected from the regular battery terminals and a twisted wire should be connected to the filament terminals of the socket. A 10 ohm center-tapped resistor should be shunted across the filament terminals, and the center point of the filament resistor should be connected to the negative B battery terminal.

The two terminals marked "P" and "B" are connected to the output terminals of the set, with "P" connected directly to the plate of the detector tube and "B" connected to "+B," detector. The other filament and plate terminals for the amplifier are indicated on the diagram. The plate and grid voltages for the last audio tube depend on the type of tube employed, and the correct values can be determined by re-

ferring to the data sheet which accompanies each of the tubes. The terminals L.S. are connected to the loudspeaker or, if the volume is not sufficiently great (such as when signals from great distances are being received) to the phones.

One point which might cause difficulty is the fact that the "-A," "-B" and "+C" terminals are all connected together in the diagram. If the "+A" and "-B" are connected together in the set, they should also be connected together in the amplifier. In other words, the common terminals for the batteries should remain exactly the same in the amplifier and set, so that a short-circuit will not occur in the filament wiring.

A Band-Pass Filter for 115 K.C.

ONE of the most interesting questions that we have received lately, is one in reference to the construction of a band-pass filter for the intermediate frequency amplifier of a superheterodyne. The advantages of a band-pass filter are definitely established, and the difficulty in obtaining or building this type of filter seems to be the only reason why they are not used more in sets. The design of a band-pass filter is not very simple but if data can be obtained for the values of inductance and capacity that are required for the various sections of the filter, the actual construction is not too difficult for the average experimenter. An article was published in the Spring Edition of the *Radio Listeners' Guide and Call Book*, with tables of the necessary values for a number of different frequencies which are used most commonly in superheterodyne practice.

In order to obtain the most satisfactory results with an intermediate frequency amplifier in which a band-pass filter is employed, the coupling transformers should be tuned rather broadly. The letter which we refer to above was sent by Mr. J. B. O'Halloran of St. Paul, Minn. Mr. O'Halloran desires to use a band between 110 and 120 kilocycles for the intermediate frequency amplifier in his superheterodyne.

We are showing the diagram of a three-section filter which is made with these requirements in mind. The coupling resistor, R1, has a value of 12,000 ohms, which matches the plate impedance of the 201A tube when a plate voltage of 45 is used. The condensers C1, C2, C3 and C4 have a value of .0001 mfd.; the condensers C5, C6 and C7 have a value of .0025 mfd., and the inductances L1, L2 and L3 have a value of 0.724 millihenries. The inductance coils can

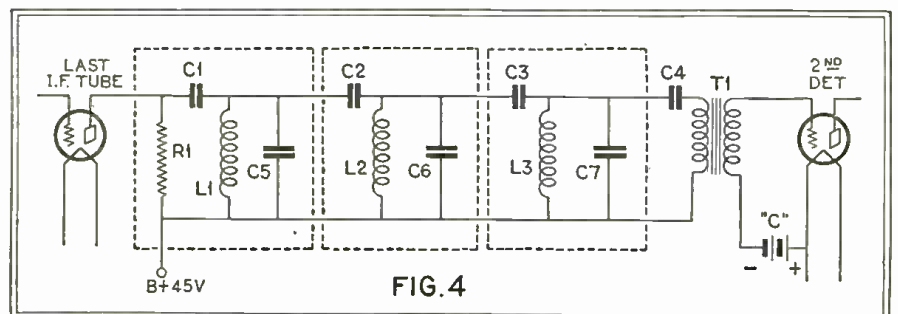

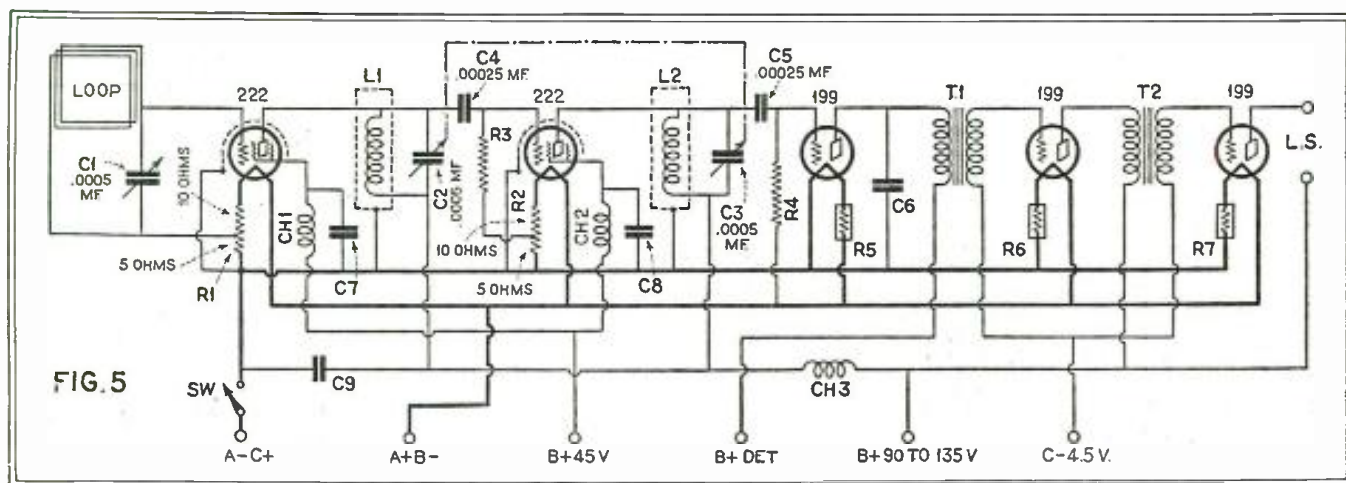

be wound on $1\frac{1}{2}$ " bakelite tubes, $2\frac{1}{2}$ " long, and each coil should contain 170 turns of No. 30 enameled wire.

Each section of the filter must be enclosed in a separate metal shield. The easiest way for us to make the shields is to take sheet copper and cut it so that one oblong piece correctly bent is used for the sides and two separate oblong pieces are used for lid and base. In other words, we are merely making a copper box, and since copper is easy to solder we will have no difficulty in making it rigid. Each of the shield compartments should be $4\frac{1}{2}$ " long, $3\frac{1}{2}$ " wide and $3\frac{1}{2}$ " high. The coils should be placed in the exact center of the shields with the various condensers and the resistor for the input arranged in convenient positions around them.

Transformer T1 in the diagram (Fig. 4) is one of the intermediate frequency transformers in the set. Plate detection should be used for the second detector, since this method of detection will handle much more current than the grid leak method.

A Portable Receiver

QUITE a number of our readers appear to be interested in the construction of a portable set to be used in a car. A set which will operate efficiently in this position must have considerable amplification because of the comparatively poor pick-up which will be obtained. In Fig. 5 we are showing a schematic diagram of a 5-tube set, using two screen-grid tubes and three UX-199 tubes. Although the apparatus in this set seems to take considerable amount of space, it can actually be arranged in a small enough cabinet which can be conveniently used in a car. Individual shields are used for the coils and tubes instead of the usual method of using complete "stage shields." This conserves space and also allows more flexibility in the construction of the set.

The coils L1 and L2 are wound on 2" tubes and contain 70 turns of No. 26 D.C.C. wire. The shields for these coils should be either box-shaped or cylindrical, and they should be $3\frac{1}{2}$ " across or in diameter. The filament resistors R1 and R2 have a value of 15 ohms with a tap at 5 ohms. This tap provides the C

bias for each of the tubes. Resistor R3 is a 2 megohm resistor which completes the grid circuit of the screen grid tube. Resistor R4 is also a 2 megohm resistor and is used as the grid leak. Resistors R5, R6 and R7 are filament ballast resistors designed for use with the 199 type tubes. Condensers C1, C2 and C3 are variable condensers; C2 and C3 may be ganged together. C4 and C5 are coupling condensers while C6, C7, C8 and C9 are by-pass condensers. C6 has a value of .002 mfd. and the other three by-pass condensers have a value of 1 mfd. The transformers T1 and T2 are ordinary audio frequency transformers with a ratio of 2 or 3 to 1. The choke coils CH1, CH2 and CH3 are radio frequency chokes with an inductance of 80 or 85 millihenries.

In laying out the parts for the set, care must be taken to prevent any feedbacks occurring between the various stages. In order to do this, the grid and plate leads should be kept as short as possible and if practical, they should be enclosed in copper tubing with the tubing grounded to the negative filament. The loop aerial is one of the ordinary types and a suitable one may be made at home if desired. A wooden frame, 18" square and wound with 15 turns of No. 18 or 20 wire around the frame with a spacing of $\frac{1}{4}$ " between the turns will be suitable.

After we have assembled the set, the next thing to do is to connect the batteries. The filament supply consists of a group of dry cells with three cells in series for each section. If two of these sections are made and the positive and negative terminals of these sections are connected together, the battery will last much longer than if a single section were employed. In connecting the three cells in series, the positive terminal of the first cell should be connected to the negative terminal of the second; the positive of the second should be connected to the negative of the third and the remaining positive and negative terminals should be connected to the filament circuit of the receiver. If possible, a "B" supply of 135 volts should be used, although satisfactory results can be obtained with 90 volts on the plates of the screen grid tubes.

The construction of the set for use in

an automobile brings another point to mind. If the set is to be used while the car is in operation, trouble might be encountered with interference from the ignition system. The most practical way to overcome this interference is to place resistors or choke coils in series with the leads from the spark gaps. If resistors are employed, they should have a value of 20,000 ohms and should be of the carbon type. If choke coils are used, they should be wound with heavy wire. A suitable choke may be wound by winding 8 to 10 turns of No. 16 D.C.C. wire on a tube $1\frac{1}{2}$ " in diameter. This choke coil is merely placed between the spark plug and the wire from the distributor. The choke coil should be shielded in a metal can to prevent inductive reaction between choke and the receiver.

The portable set which we have described above is only portable from the standpoint of being transported in a car or other suitable conveyance. The batteries and apparatus in the set would make it too bulky and heavy to be carried by hand, and it could not be made lighter without reducing its efficiency.

By-Passing the "C" Bias Resistor

ANOTHER of our readers, Mr. Julius Berger of New York City, questions the uses of a by-pass condenser in shunt with the "C" biasing resistor in an audio amplifier. Part of Mr. Berger's letter reads as follows: "I can understand the need for by-passing r.f. circuits when resistance is introduced in tuned circuits because of the tendency to broaden tuning, but why are these condensers necessary in audio circuits. The latter circuits are not tuned. Also, why the large capacity condensers, often 4 mfd. for the last tube."

The need for this by-pass condenser is easily understood when we realize that the "C" biasing resistor is connected in series with the plate supply, and all audio frequency currents in the primary circuits of each of the transformers in the set must pass through this resistor. Naturally it offers an appreciable opposition to the flow of audio frequency currents and the result of not using the condenser is a marked reduction in the volume as well as a loss in quality. By connecting a larger condenser of 1 mfd. or more across

the resistor, the direct currents of the plate supply pass through the resistor which supplies the required "C" bias, while the audio frequency currents flow through the by-pass condenser.

Another reason why the "C" biasing resistor must be by-passed is because this resistor is common to all of the plate circuits of the amplifier tubes and provides a common coupling circuit between each of the stages. This coupling between stages introduces distortion as well as making the amplifier unstable.

In reference to the use of a large capacity for coupling the last tube to the speaker, it is often found that a condenser of 1 or 2 mfd. will give the same quality as a larger condenser, but in order to pass the greatest amount of current to the speaker, it is advisable to use a larger condenser. For this reason, capacities up to about 8 mfd. are sometimes found in the loud speaker coupling device. It must be remembered that all of the audio frequency currents which actuate the speaker must

pass through this condenser, and the lower the impedance of this condenser the lower will be the loss in volume which occurs in this circuit.

The subject of by-pass condensers and their uses is one that has been lacking in radio publications and books in the past. Most radio experimenters believe that by-pass condensers are a luxury but those who have tried the correct use of these condensers soon find that they are quite necessary to the correct operation of the set.

The Serviceman

Tube Data for A.C. Sets

MOST service men who have repaired power-operated receivers are familiar with the difficulties that are encountered with some of the a.c. tubes. Mr. J. A. Ess, who is a service man in Hopkins, Minn., has analyzed the troubles encountered with these tubes, and although his statements are rather "strong" in the matter of certain types of a.c. tubes, his suggestions are quite interesting, and we feel sure that they will solve some of the queer problems that are encountered with the operation of these tubes:

"Most service men have encountered servicing problems with a.c. sets, in which the '27 type tubes would not stand up. The reasons for these tubes failing to operate over a considerable length of time are rather numerous, but they are usually brought down to several main points, such as fluctuations of line voltage, and excessive filament temperature. Fluctuations of the line voltage usually cause more trouble when only one of the '27 type tubes is used in the set, since there is only one filament shunted across the wiring. In some cases, the breaking of the filament may be due to the differences in the consistency of material used in the insulation sleeves surrounding the filament. It seems that the expansion and contraction of turning the set on and off breaks the filament eventually. This trouble may be noted in some cases by the periodical interruption of reception or by testing the tube in a regular tube or set tester.

"This variation of tube breakdown is a rather interesting one, since the tube seems to act as a thermostat and when the set is turned on, reception will be normal immediately after the set gets 'hot' and then gradually fades to nothing, in the period of time varying between 30 seconds and a minute. Then reception builds up again, as if the switch had been turned on again. The reason for this phenomenon, of course, is due to the filament heater expanding as it becomes hot. If the filament wire is broken, this expansion of the insulating material and cathode separate the two sections of the filament until the cathode begins to cool. At this time, the two parts of the filament are brought together again and reception starts for a short time until the

heating again separates the sections of the filament.

"Then there is the type of tube which has a 'bright spot' or a very bright filament. This is usually due to the filament being short-circuited inside of the insulating sleeve so that only part of the filament is heated. Naturally this shortening of the filament length causes it to get very hot and the life of the tube is usually short. Some makes of tubes show this more readily than others, and in some cases it is not possible to note the difference until the filament has finally 'burnt out.'

"Another affliction to which these tubes are subject is the soft, rasping sound varying in intensity (very similar to the noise caused by the arcing across sections of a high-voltage supply but much lower in intensity) and is due to a break in the filament similar to that mentioned above.

(By the way, this was a brand new '27, installed that same day to replace another defective tube of the same type.)

"Of course, the latter case was an extreme one and it required considerable length of time to coordinate the noise with the slight flickering of the filament. Service men will only receive calls for this last-mentioned cause, from critical music-loving fans who are very particular how their sets reproduce. Ninety fans out of one hundred would not notice this, since most of them use too much volume to detect the noise and others do not care, since they expect a certain amount of noise from their sets. Even service men very seldom detect it unless their attention is called to the condition by their customers.

"I could go on for hours relating experiences with filament fracture in its different stages, and the way in which it shows up in different sounds issuing from the loud speaker. One solution to the problem is to install a new tube of the same type, but trouble is usually encountered again after a short time, and I have found a solution to the problems which is very gratifying. This consists of replacing the '27 tube with one of the 'Kellogg' or similar types. Since these tubes have a four-prong base, some alterations have to be made in order to use them.

"I secured an old type '27 tube and removed the glass, leaving only the base. In the side of the base about 1/4" from the bottom, I drilled a 3/16" hole and fastened a twisted cable to the two filament prongs after passing it through the hole. This cable provided the means of lighting the filament of the 'Kellogg' tube, as the filament terminals of this tube are at the top. Then I fastened a four-prong socket to the five-prong tube base, as shown in the illustration, by passing a machine screw through the middle of the tube base. Finally, I fastened the grid, plate and cathode terminals on the tube socket to the corresponding terminals on the five-prong base, by soldering short wires between them.

"It is only necessary to plug the four-prong tube into the socket, connect the two wires to the filament terminals of the top of the tube, and place this complete unit in the five-prong socket provided for the detector in the set. As

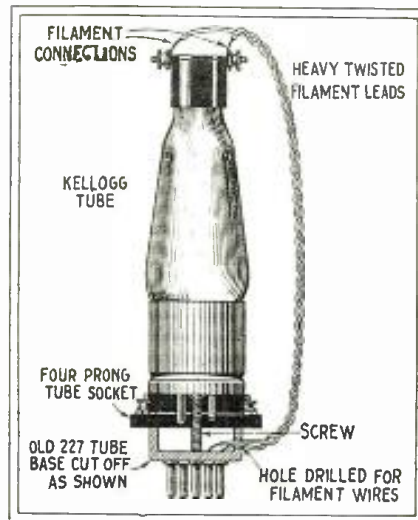

FIG. 1

In some cases, the noise is only heard when the volume is turned very low and meter readings will not show up the extremely small arcing of the sections of the filament. On one occasion, I sat fully forty minutes watching the filament of a '27 type tube after giving every conceivable test. After this period of concentration, I was finally rewarded by noting a tiny flicker of the filament of the '27 corresponding with the intermittent rasping noise issuing from the loud speaker.

the filament rating of the new tube is three volts, and the voltage supplied to the '27 tube is only $2\frac{1}{2}$ volts, there is a $\frac{1}{2}$ volt safety margin which prevents the new tube from being injured. The tube under these conditions takes slightly longer to heat up, but of course this is an insignificant point when compared to tube injury.

"In some cases, this plug-in arrangement cannot be used, since the set is not sufficiently large and the top of the cabinet will not close. In this case, the base of the Kellogg tube must be removed and the connections made directly to a five-prong tube base. The proceedings are the same in this case, except that the grid, plate and cathode terminals are connected directly to the wires running from the tube instead of to the four-prong socket.

"Because of the long life of these tubes when used with the lower filament voltage. I have been able to increase my business considerably from the boosting I received from the customers using these tubes, and I feel well paid for the time and trouble spent in preparing them. Up to date, every tube has stood the test where others failed."

Mr. Ess's experiences are rather unusual, since the five-prong tube usually stands up very well in a.c. sets. Of course, where the voltage fluctuations are bad, these tubes have a comparatively short life unless a voltage regulator is employed. In this case, the use of the a.c. tube with a higher filament voltage characteristic will probably supply a solution to the problem. We also believe that Mr. Ess's explanation for the failure of these tubes, due to the fracture of the filament, is a rather logical one, and we feel sure that other service men have encountered the same problems.

Testing Screen-Grid Tubes

ANOTHER serviceman reader of our magazine has been up against the problem of testing the screen-grid tubes with a standard tester. Under the conditions, it was not possible to obtain a special tester and some system had to be used to give an indication as to just how

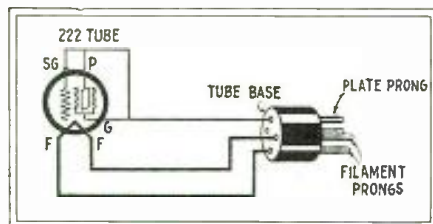

FIG. 2

well the tubes were operating. The solution to the problem was found by connecting the grid, screen grid and plate together, and connecting them to the plate prong on a tube base. The filament terminals were connected in the usual manner to the filament prongs on the tube base and this tube base was in turn plugged into the regular set tester. It was found that with 50 volts on the plate and the required 3.3 volts on the filament, the plate current on a good tube

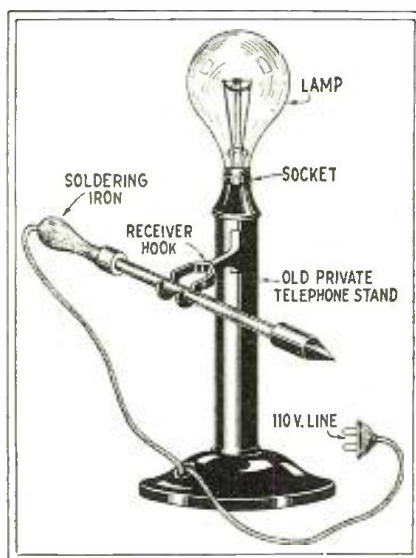

FIG. 3

should be over 12 milliamperes when measured on the plate milliammeter. This method of testing the screen-grid tubes was submitted by Mr. C. L. Sheehan, of Fall River, Mass.

A Soldering Iron Support

MR. HUBERT C. MARTIN, a serviceman in Marion, North Carolina, has found that when most electric soldering irons are used constantly over long periods of time, the resistance unit in the soldering iron becomes overheated, and in order to overcome the difficulties, he conceived the idea of using an old telephone stand with a lamp for reducing the current passing through the iron. The transmitter was removed from the stand and a lamp socket was mounted in its place by means of a $\frac{1}{4}$ " extension and nut. The latter two parts are made for table lamps and similar devices. The receiver hook was notched, as shown in the illustration, to provide a support for the soldering iron and the switch inside of the stand was connected so that the lamp was in series with the soldering iron when the hook was down. The switch then short-circuited the lamp when the receiver hook was up.

If the soldering iron is kept on the receiver hook as shown in the accompanying illustration, it cannot overheat, as the lamp is connected in series with it. The temperature of the iron is controlled by the size of the lamp, and it is usually found that the 100-watt size is correct. Besides making a satisfactory protection for the soldering iron, this stand provides a convenient holder for the soldering iron where it is accessible but still "out of the way."

Some Servicing Experiences

QUITE a number of dealers have found that they were not able to make the retail business a profitable one, and it seems that many of them have come to the conclusion that radio and profits do not go together. Of course, the location and the line of apparatus have a great deal to do with the situation, but in many

cases it is the service end of retailing which causes the downfall. Mr. B. F. Webster of Webster's Music and Radio Shop, in Canton, Ohio, wrote to us after having some experiences in this matter, and his suggestions may be of assistance to other dealers and service men. He has used the system for a number of months, and it has shown a very clear profit.

After discovering that the servicing end of his business was causing a large loss, Mr. Webster decided to stop giving free service in the usual way, for a period of time after a set was sold. In place of this service, three free service calls were allowed with every set and a service charge was made for all additional calls. Instead of speaking of service when selling the receiver, he emphasized the quality of the set, the quality of available programs and the three free service calls which he allowed. The difference between the old service and the new is in the fact that Mr. Webster stopped using free service as an incentive to buy and substituted quality of the set as his sales argument.

The paid servicing was continued and the system included the use of a book which was fastened near the telephone. When the servicing call was received, the name, address and type of set were marked down in the book, and the serviceman would take his calls directly from this book. This saved time and unless the service men were very busy, they would be able to answer the calls more quickly. A special form was also made up and kept on file after the servicing was complete. Among the other points noted on this form were the date, the type and number of the set, the make and number of tubes and a report of the condition of the set before and after inspection. An extra form was used when it was necessary to remove the set from the customer's home and this form also served the purpose of a receipt. After the set was returned in good condition, the form was signed and this supplied a record of all of the conditions.

One of the main points in the form was the price of the set (if it was bought from Mr. Webster's store) and the number of servicing calls and fee charged after the three free calls were used. It was found that the free calls were used up very quickly and the fees charged for later calls soon made the servicing end of the business a real profit maker. Other radio dealers who are encountering the same problem might consider these points, and although they may be revised to suit local conditions, they are undoubtedly sound from a financial standpoint. The printed forms are a particularly good point, since they show immediately the profit of the sale including the cost of the service.

Electrolytic Condensers

MR. D. A. Brown, of Marion, Ohio, sends in some interesting data on the construction and repair of electrolytic condensers of the types used for dynamic speakers and "A" power units. His suggestions are as follows:

"A very simple way to eliminate A.C. (Continued on page 78)

The Trade Broadcasts:

New Equipment and Manufacturing Trends

A New Screen-Grid Receiver

ATWATER KENT is one of the first manufacturers to put a ready-to-use screen-grid radio receiver on the market.

Many new features are claimed for the new models, chief of which are perfection of tone, reproduction and elimination of hum or extraneous noises. It is said that the utilization of the screen-grid tube has produced an instrument which is practically silent, except for the desired sig-

nals if an outdoor wire is inconvenient."

The new receiver marks a departure from previous Atwater Kent models in another important particular. It has an illuminated station dial instead of the full-visioned disk characteristic of former models, as shown in Fig. 1. Announcement is also made concerning screen-grid radios in cabinets. The new set is offered as a table model with separate speaker, but it also may be pur-

type, known as the EC-35-KN3 and the EC-35-KFB. On both models as on all models of this type, the capacity is varied by means of a screw, which runs through a phosphor bronze spring plate and which controls the distance between this plate and a piece of brass mounted on a bakelite slab. A piece of specially treated mica acts as the dielectric medium.

The EC-35-KN3, shown in Fig. 2, contains any number of equalizers mounted on a bakelite strip. The adjusting screw is "dead," since it is insulated from the spring plate with a "bakelized" canvas washer. This prevents any variation of capacity when the adjustor is taken away.

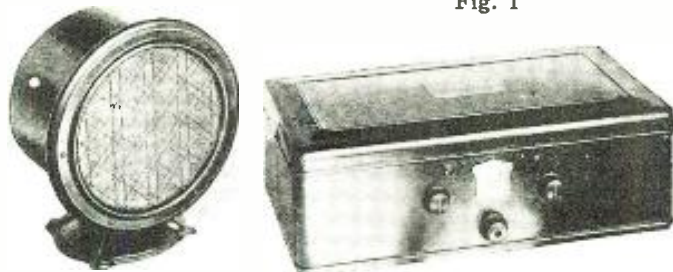

Fig. 1

nals which come into it from the antenna. It is so quiet that its makers have deemed it necessary to equip it with a pilot light, so that the operator of the receiver may know at all times whether the power is turned on or off.

The new radio has been produced after a long period of experimentation and testing in the Atwater Kent laboratories. Its producer feels that in its perfection and its highly sensitive and precise character it represents the culmination of his twenty-seven years of experience as a manufacturer of electrical equipment.

A statement issued by the company says, among other things:

The new screen-grid radio has "enormous power, needle-point selectivity, longer reach and magic tone. It takes more out of the air and brings more into your home. It is vastly more powerful. Yet all of this new energy is completely under control—as obedient to the fingers of a child as to those of a radio engineer.

"All unwarranted noises are filtered out. The only sound heard is the music and voices from the broadcasting studio. The electro-dynamic tone is so pure that the listener feels he might reach out and touch the artist. For stations fairly near by very little power is utilized. The reserve is tapped by turning the 'local-distance' switch, just as a driver presses down the accelerator to make his car go faster. Stations way off across the map which perhaps have been only names come in clearly. Every station—every program is clear. They are not elbowed out by others, because the new screen-grid radio has needle-point selectivity. Furthermore, only a short indoor antenna is

chased in cabinets. To house the new set a large number of America's finest furniture makers have designed cabinets exclusively for it, ranging from simple to elaborate and available at all Atwater Kent dealers.

Hammarlund Condensers

THREE new models of the popular EC type equalizing and MC type midget condensers have been brought out for manufacturers by the Hammarlund Manufacturing Company, New York



Fig. 2

City. for the past 18 years manufacturers of apparatus which has gained worldwide recognition because of its exact and sturdy manufacture.

There are two models of the equalizing

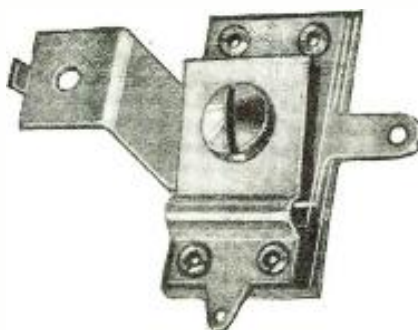

Fig. 3

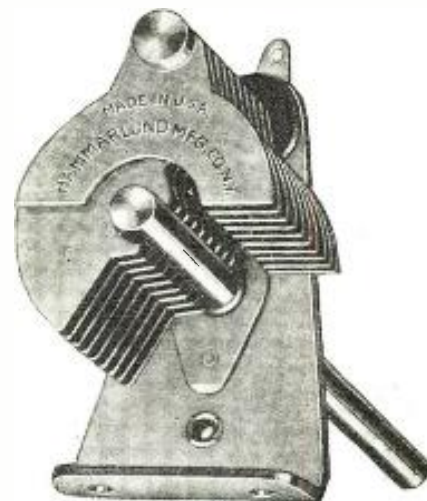

Fig. 4

It can be used for both neutralizing and equalizing and is made in any capacity, e. g., from less than 2 mmfd. to more than 35 mmfd., or less than 20 mmfd. to more than 100 mmfd.

The EC-35-KFB, shown in Fig. 3, has a special bracket which enables it to be inserted into a slot in the subpanel, thus aiding its support and simplifying the wiring. It is also made in the same capacities as the EC-35-KN3 and can be used for feedback control, equalizing or as a grid condenser in short-wave receivers. It has a "live" screw; a wooden adjustor is used to prevent capacity variation.

The midget condenser, MC-19-G shown in Fig. 4, is principally designed for antenna tuning with a special base mounting and a long brass shaft for operation from the panel, its length being made to suit. These midgets are made in capacities from 16 mmfd. minimum to 100 mmfd. maximum. The plates are cut in straight line capacity style, being made of brass and soldered to a brass shaft. Bakelite insulation is used. Lock washers are placed underneath all screws. The mounting plate is made of chemically treated steel.

Raytheon Rectifiers

THE Raytheon Manufacturing Company of Cambridge, Massachusetts, is the manufacturer of two new high voltage rectifier tubes, one of which is illustrated in Fig. 5.

The type S tube, designed for use in transmitting circuits, employing trans-



Fig. 5

mitter tubes of the 852, 860, 861 and 204A types, will supply voltages from 2000 to 3000 volts at currents up to 300 milliamperes, when used with proper filter units.

The type SX tube, when used with suitable filters, is designed to supply voltages from 1500 to 2000 volts at currents up to 250 milliamperes.

It is especially adapted for use in circuits employing the 210, 852, 860, 211 or 203A transmitting tubes.

A New Stewart-Warner Series

THE Stewart-Warner Corporation, of Chicago, Illinois, has introduced a new line of receiving sets which will be known as the Series 900. These sets are mounted in a number of different cabinets to suit the purse and blend suitably with furniture already in use in the home. They include several consoles as well as a table model receiver. A number of new features have been added to the design of former sets made by this company, and include the use of a "balanced bridge" circuit which is said to completely eliminate oscillation disturbances without the use of suppressors or lessor controls. It is claimed that the use of this balanced method permits reception from greater distances, and also allows quality reception on distant stations. The balancing method is not affected by tube capacity and for this reason no trouble is encountered when new tubes are placed in the set. One other feature of the receiver is the use of two of the new UX245 power tubes in the last audio stage which is a push-pull amplifier, thus supplying a high order of tone quality.

The radio frequency coils are all individually shielded in sheet copper cans in order to prevent any interaction from taking place between them. Additional features of the receiver are the use of extra large power transformers; an improved filter system for the "B" power unit and dynamic speaker; an automatic voltage control which takes care of line voltage variations; an electric phonograph jack which allows a magnetic pick-up to be connected to the amplifier and a plug-in arrangement for television reception. This last point is unique in manufactured sets and of course its use is dependent upon the development of television in the near future.

In adjustment at the factory the tuning coils are balanced by crystal controlled oscillators and the tuning condensers are constructed with special care to prevent trouble in the matter of unbalanced circuits. In developing this new line of

receivers, the manufacturers also designed a new unique precision instrument for testing the operation and efficiency of sets. This test instrument provides an accurate test of the balance and efficiency of each section of the receiver individually.

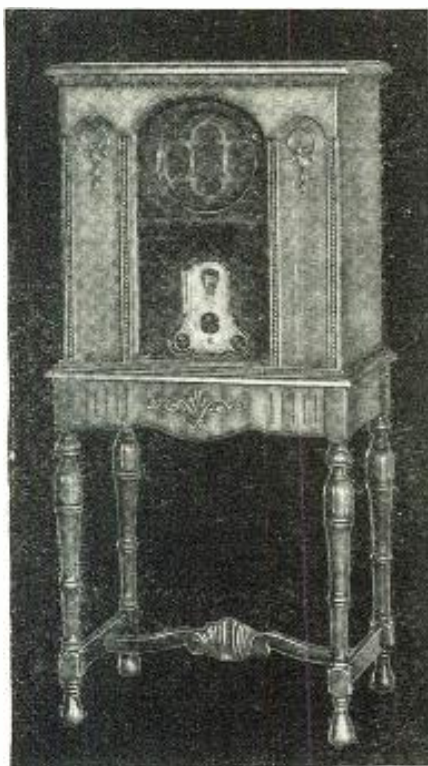

Fig. 6

The accompanying photograph, Fig. 6, shows the Sheraton Period console housing the new receiver and an electrodynamic speaker. Sliding doors cover the speaker and panel when the set is not in use.

A New Phonograph Pick-Up

AN improved model of the magnetic phonograph pick-up unit manufactured by the Best Manufacturing Company, of Irvington, N. J., has been announced. This phonograph pick-up has



Fig. 7

been improved both electrically and artistically and now comes complete with a volume control and a tube adapter. The accompanying photograph, Fig. 7, shows the three parts of this unit. The pick-up with its supporting arm and swivel are all finished in a gold crackle effect.

The volume control is of the resistor type and the tube adapter is a simple disc which fits over the prongs of a vacuum tube. The supporting arm is

swiveled horizontally but does not swivel vertically. The pick-up unit itself is supported on this arm and since it is light in construction, the wear on the record is reduced to a minimum. The swivel base is equipped with holes so that it can be mounted permanently in the phonograph cabinet.

The Simplex Public Address System

THE development of high quality amplifiers in radio receivers has produced a demand for amplifying which can be used for amplifying voice and music in large auditoriums such as public schools, hotels, theatres, factories, public buildings and outdoor resorts. Realizing the demand for amplifiers of this type, the Simplex Radio Corporation of Sandusky, Ohio, has introduced a combination power



Fig. 8

amplifier and power supply with an electric phonograph turntable, microphone and an 8-tube single-dial receiving set, all of which, with the exception of the microphone, are placed in a console cabinet, as shown in Fig. 8. The phonograph arrangement may incorporate either a single or double turntable, as desired, since in some cases it is necessary to have a continuous rendition of music. Of course, it is not possible to do this with a single turntable and pick-up. The microphone used with this arrangement is the same type as those employed in broadcast stations, and is mounted on an ornamental pedestal which may be raised and lowered to suit.

By simply throwing a switch on the front panel, the operator may change from radio to phonograph or to the use of the audio channel, with the microphone as a speech amplifier. The entire equipment is electrically operated and requires practically no attention. The current consumption is equivalent to a single 100-watt lamp.

Loud speakers especially designed for use with this installation are also manufactured by Simplex.

The double turntable unit is designed particularly for use in theatres, while single turntable units may be used where continuous rendition is not required.

Some New Polymet Apparatus

FOUR new devices which are being introduced by the Polymet Mfg. Corp. of New York City are shown on this page in Fig. 9 A, B, C and D. The first shown at "A" is a volume control of the resistor type made with a metal shell and a resistance element composed of a special compound. The metal shell of the resistor is 1½ inches in diameter. This type of resistor is made in various values, all higher than 5,000

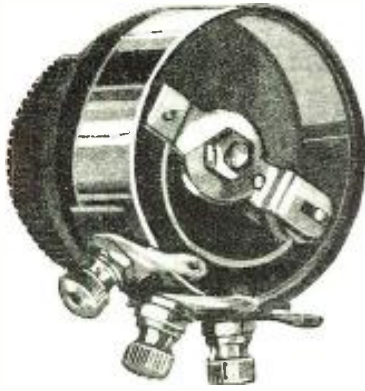

Fig. 9A

ohms. The second type of resistor, shown in "B," is of the wire-wound type having a bakelite shell. An unusual type of contact arm provides a firm contact to the wire without excessive wear to the latter. This type of Polymet volume control is recommended when a resistance value of less than 5,000 ohms is required.

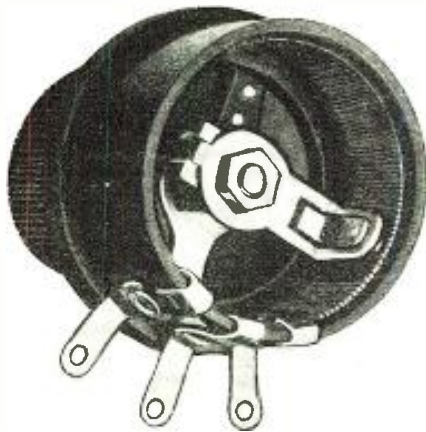

Fig. 9B

The third new device manufactured by this company is a small moulded fixed condenser with mica insulation between the condenser plates. The condenser is equipped with two mounting holes through the bakelite body which permits the condenser to be mounted on a metal panel. The bakelite case is extremely small, being ¼ inch by 1½ inches by 21/32 inches. Capacities up to .006 mfd. may be obtained.

Polymet also introduces a new adjustable condenser which is particularly suited



Fig. 9C



Fig. 9D

to aligning gang condensers or the neutralizing of receivers, etc. The capacity range varies from practically zero capacity up to .0003 mfd., the capacity variation being obtained by means of a screw mounted outside of the plates. The condenser is well made with mica insulation and the plates and mica are nested in a moulded bakelite base. The folded-over edges of the top plate provide a uniform capacity and extreme rigidity. This new semi-variable condenser is shown at "D."

National's New Color Dial

AN entirely new idea in the construction of dials has been introduced by the National Company, of Malden, Massachusetts. This dial is not only modern in appearance but is ultra-modern in its mode of operation. The drawing of this dial shows how the "rainbow" effects are obtained. When the set is turned on, the ground glass front of the dial lights up and a single scale number appears. As the dial is turned, figures continue to fade in and out of view; standing out clearly for a brief second and then fading out. This is also accompanied by a rapid play of vari-colored lights for a background. The effect is a very pleasing one and lends an entirely new touch to general appearance of a receiver. The escutcheon plate of the dial is shown below.

Referring again to the sketch, Fig. 11, it will be seen that a drum or wheel containing a translucent screen of various colors revolves around the electric light bulb. The numbers on the projection drum are cast up to the ground glass in conjunction with the color from the color wheel. The combination of the two

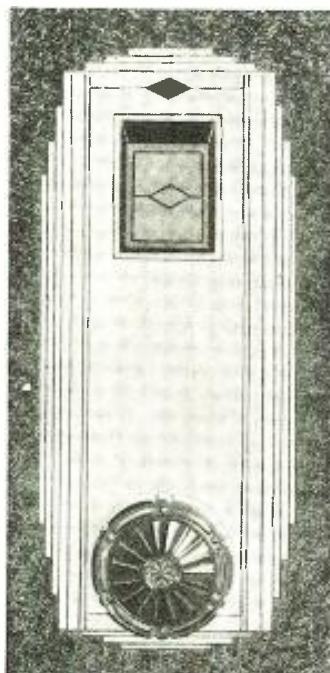

Fig. 10

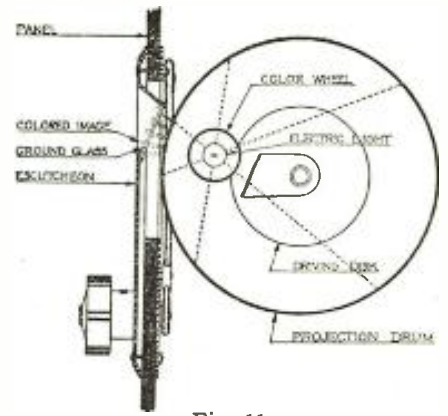

Fig. 11

effects, besides being new, is extremely practical and this dial will undoubtedly figure in the designs of receivers for the coming season. Figure 10 shows the appearance of this new dial.

A Bosch Radio Phonograph Combination

AT a recent private showing at the Hotel Astor, New York, the American Bosch Magneto Corporation, of Springfield, Massachusetts, introduced their new Model 30 radio-phonograph combination. This new combination unit is contained in an unusual cabinet which



Fig. 12

allows easy access to both the phonograph and radio without marring the appearance of the complete set. The phonograph turntable and pick-up are placed at the top of the cabinet, with the set directly below, as shown in Fig. 12. The speaker unit is placed at the bottom and is of the dynamic type.

The electric pick-up unit for the phonograph is the new Bosch recreator. A

clever switching arrangement in connection with the radio station selector enables one to shift from radio to phonograph with a slight turn of the station selector knob. The phonograph is automatically connected to the amplifier and speaker when the station selector is turned below zero. Two compartments on either side of the speaker provide storage space for phonograph records.

The cabinet which houses this set and phonograph is 45½ inches high, 36 inches wide and 19¼ inches deep. It is made to appeal particularly to the discriminating buyer who desires a receiver of pleasing appearance. Sliding doors, which are becoming so popular in the newer manufactured sets, are used to cover the upper part of the console which encloses the phonograph and set; swinging doors are used to cover speaker.

The electric motor, which operates the turntable, is made by the General Electric Company, and is of the brushless induction type. Because of the absence of moving contacts in this motor which might otherwise cause the production of static noises, no trouble is encountered from "interference" of this sort which might be picked up by the receiver. An automatic stop is provided which turns off the motor after the record has been played. The set used in this new console assembly is the Bosch Model 29 receiver, which employs five 226 type tubes, one 227, two 281 and one 210.

Pilgrim's Progress in Radio

A RECENT publicity release from the Arcturus Radio Corporation includes a graph showing the development of the use of power tubes. The gradual upward trend from the use of the 201A to the 250 and back to the 245 is shown in Fig. 13 and is called "Pilgrim's Progress in Power." By referring to the graph, it can be seen that the power required for the normal volume required by a broadcast listener lies between 1 and 2 watts of undistorted power. It can also be seen that the ordinary set using a single tube of the 171 type cannot supply this undistorted output and that either two 171's or a larger power tube must be used.

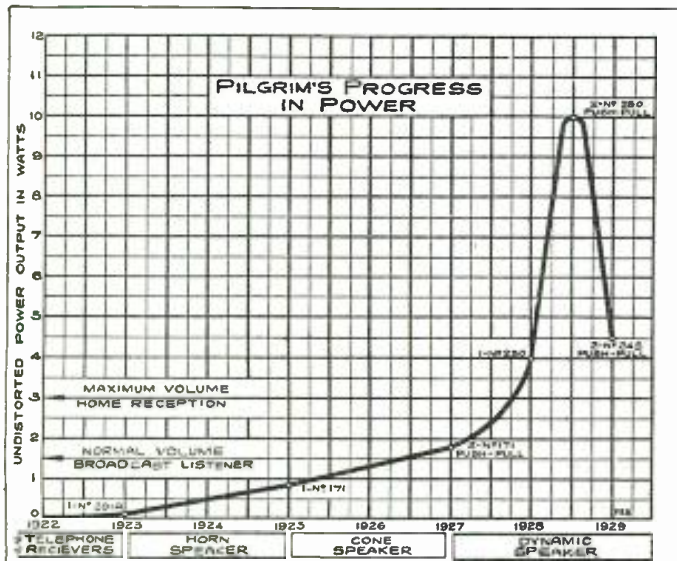

Fig. 13

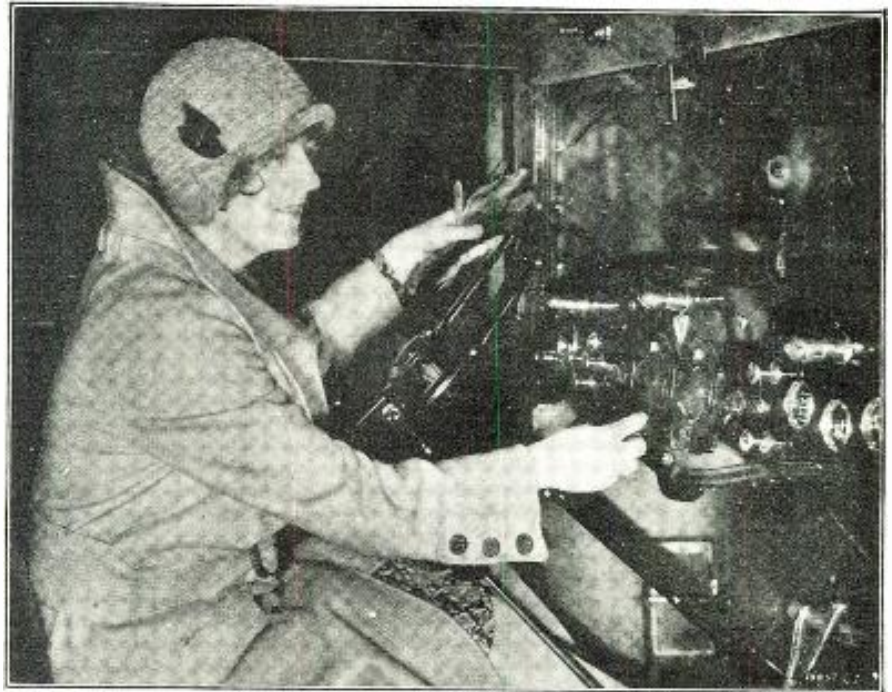

Fig. 14

It is interesting to note the date of development of the various power amplifiers, beginning with the use of a single 201A in 1923, developing into a single 171 in 1925, and gradually progressing to two 250 tubes in push-pull between 1928 and 1929. The latest step, as shown, is in the use of two type 245 tubes in push-pull—which seems to provide the ideal conditions. With such a combination more undistorted power output is obtained, and at a lower plate voltage than when using a single 250 tube. By referring again to the diagram, it is seen that the undistorted output of two 245 tubes when used in a push-pull arrangement is much higher than the maximum volume required for home reception, thus providing, economically, a reserve of power.

This new tube supplies an undistorted output of 1.7 watts when supplied with a plate potential of 250 volts. In an

efficient push-pull circuit, the engineers of Arcturus claim that with two of their 145 tubes an undistorted power output of 4.8 watts will be delivered to a good dynamic speaker.

THE POWER OUTPUT REQUIRED BY VARIOUS TYPES OF LOUD SPEAKERS TOGETHER WITH AVAILABLE POWER TUBES IS CLEARLY INDICATED IN THE ACCOMPANYING CHART

Automobile-Radio Combination

THE difficulties standing in the way of operation of a radio in a running automobile have been surmounted, according to a statement made by the Automobile-Radio Corporation of 37-7 Queens Boulevard, Long Island City, N. Y. This auto-radio receiver has been developed as a result of four years of research work and given a thorough test for months on a number of different cars in all parts of the country.

The set consists of a six-tube, six-volt radio receiver, completely enclosed and properly shielded by a copper box installed behind the dash with the radio dials placed in the center of the instrument board. Standard tubes are used, mounted in cushioned-base sockets which so effectively absorb the vibration that the tubes are as long-lived as in a home set. The tubes used are three 201A type in the radio-frequency sockets, one 200A in the detector socket, one 201A in the first audio frequency socket and a 112A in the last audio stage. The set uses a tuned radio-frequency circuit, with three stages of tuned radio-frequency amplification, a detector and two stages of transformer-coupled audio amplification.

In order to maintain a balance in the dashboard appearance, the usual dash instruments are rearranged and mounted in a grained bakelite panel. The aerial for closed cars is a copper netting concealed in the top of the car, entirely out of sight. For open cars, the aerial is made of heavy flexible copper cable woven criss-cross into a heavy canvas top of the car.

A loud speaker is mounted inconspicuously over the windshield on closed cars and under the instrument board in open models. A connection on the dash permits an external loud speaker to be plugged in and used at a distance from the car. The tubes of the set are operated from the regular storage battery of

the car and the plate supply is obtained from batteries placed in a metal box under the floor, where they are readily accessible.

It is claimed that ignition noises are entirely eliminated by an ingenious sound filter system. Reception is very nearly at a par with home reception at all speeds. There are no external wires visible. The radio set is an integral part of the car, out of sight except for the two dials, but available for immediate use. The photograph at Fig. 14 shows the appearance of the revised dashboard.

A Broadcast Station Microphone

ALTHOUGH most radio enthusiasts are not directly concerned with broadcast type of microphone, there is sufficient demand for these units in public address installation to interest a number of manufacturers. The Gotham Engineering and Sales Company, of New York City, has introduced a new microphone of the two-button type containing a stretched du-

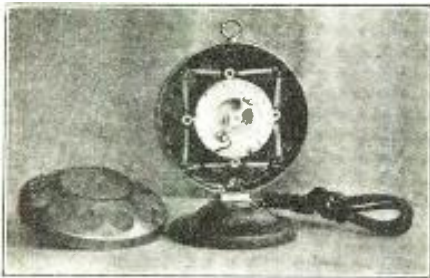

Fig. 15

ralumin diaphragm. Gold contact surfaces are used on the diaphragm and the complete microphone has been designed to produce a very flat frequency response curve. Microphone "hiss" is reduced to a minimum by special design features. These microphones are available either with the deskstand as shown in Fig. 16, or they may be obtained unmounted.

The Sterling All-Purpose Tester

A NEW set and tube tester which is intended for the testing of sets using D.C. or A.C. tubes as well as the new screen-grid tubes, is announced by the Sterling Manufacturing Company, Cleveland, Ohio.

This instrument tests all types of tubes, including the screen-grid and rectifier tubes, and is also equipped with an a.c. voltmeter for measuring the line voltage. A socket connector with a number of adapters permits the checking of current and voltage conditions at each socket or stage in the radio set. Six meters are employed so that the reading of each meter will be kept as simple as possible. Only two of the meters are equipped with double scale readings and these are very clearly marked in order to avoid confusion. The meters are connected

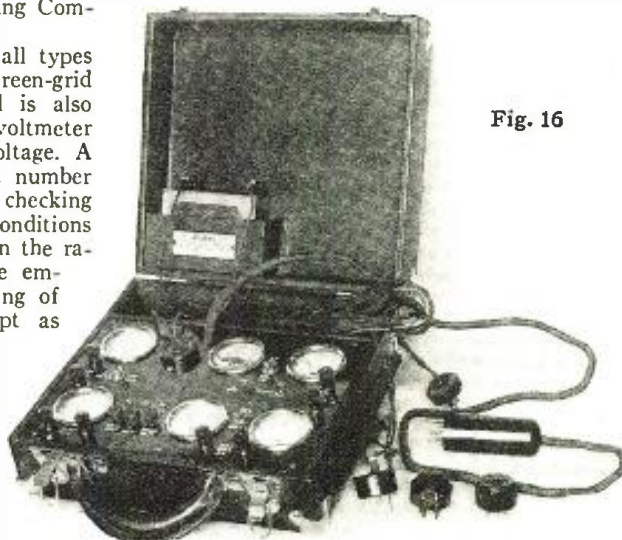

Fig. 16

to binding posts and may be used as separate measuring instruments. The meter scales are as follows: 0-50 volts A.C. for line voltage tests; 0-3, 0-15 volts A.C. for filament voltage tests; 0-10 volts D.C. for direct current receivers; 0-500 volts for plate voltage; 0-125 volts for plate, grid and screen grid voltage tests. The remaining meter is a double reading milliammeter with two scales, 0-10 and 0-100. Small toggle switches change the meters from one circuit to another and three small push-buttons permit the testing of "C" bias, screen grid voltage and a grid test for checking tubes. The complete instrument is very light and is mounted in a black leather grain carrying case, 10 3/4 inches by 9 7/8 inches by 4 1/2 inches. It weighs less than 8 pounds. An illustration of this tester is shown in Fig. 13.

Electrad Resistances

ANNOUNCEMENT is made by Electrad, Inc., of New York City of two new developments to be added to their already complete line of variable and fixed resistances.

The first, illustrated in Fig. 17 A, B and C, shows a new type of variable resistance for the control of volume in a radio receiver. The general constructional features are clearly indicated. On a metal plate shown in C, is baked a coating of enamel upon which in turn is fused, in the form of a broken circle, a film of graphite paint which comprises the resistance element. The ends of the

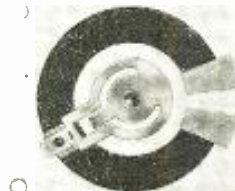

Fig. 17C

broken circle are terminated at silver contacts which make connection with the spring contacts located in the metal shell covering, shown in B.

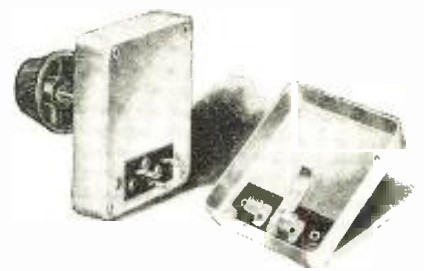

Fig. 17A and B

Pure silver, low resistance contact fingers of a new floating design are mounted on the end of the movable arm which is controlled from the outside by a knob attached to the shaft.

By the use of the all-steel construction of this new volume control there is claimed for it a greater and more rapid heat dissipation than with former types which employed the paper-coated resistance elements or the wire-wound types. Further, it is claimed that this type of variable resistance is mechanically and electrically perfect, having smooth action, long life and positive permanent adjustment of resistance within its range. This resistance unit has been designed to safely dissipate five watts at any position of the contact arm, with one-tenth or more of the resistance element in the circuit.

The second new Electrad product is the covered fixed resistance shown in Fig. 18. For use in the voltage divider section of a "B" power supply circuit or in any other part of a power circuit where there is need for a resistance unit of high order of perfection, this unit is of especial use to professional set-builders, experimenters and manufacturers because of the many advantageous qualities it possesses.

A nickel chromium alloy wire having a low temperature coefficient of resistance



Fig. 18

and low thermal expansion is wound on a tube of high value of insulation. Taps are taken off at various points along the length of the wound resistance by means of flat monel metal wire bands to which are attached large-sized slotted soldering lugs to facilitate soldering connecting wires thereto. The entire tube and resistance winding is covered with a coating of elastic black insulating varnish baked on at a temperature of 400 degrees F. Thus the units are hermetically sealed.

They are available in sizes ranging from 7 1/2 watts to 100 watts and of numerous values of resistance.

The New National Products

National Company, Inc., of Malden, Massachusetts, has added two new products to their already long line of precision equipment. The first, shown in Fig. 19, is an aluminum clip for connecting a wire to the cap of a screen-grid tube. The photograph shows clearly the use of the National grid-grip, as it is called, which maintains constant contact with the screen-grid cap of the tube by virtue of the tension exerted by the coiled section of the grip.

Fig. 19



The second product is the three-stage resistance-coupled voltage amplifier designed especially for use in speech and other audio amplifiers which employ a photoelectric pick-up. This three-stage amplifier outputs to single or push-pull power amplifier.

Note in the illustration that mounting

eyes are provided at the corners of the unit so that it may be suspended by springs or other means to prevent undue vibration. As shown, the resistance units are inserted in clips mounted on the under side of the unit, while in its interior is located the socket wiring and grid coupling condensers.

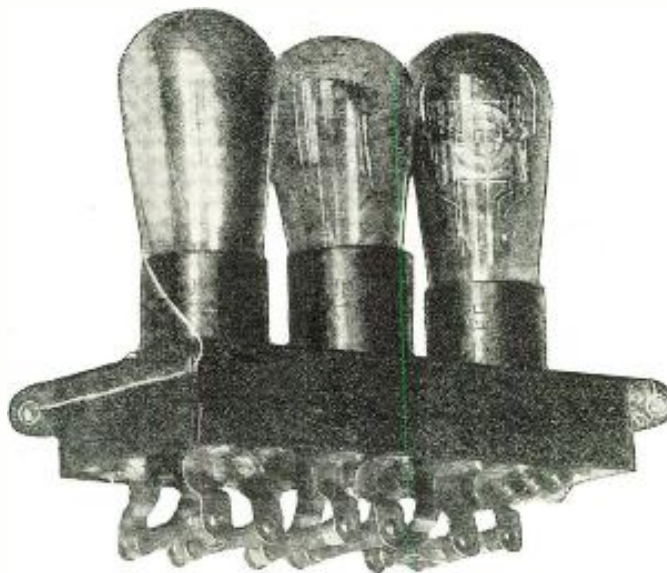

The Monophone—A One-Way Telephone For Program Service

BY GEORGE O. SQUIER

Abstract of a Paper Presented Before the National Academy of Sciences, Washington, D. C., April 23, 1929

WHAT we now call broadcasting by space-radio has already reached the "saturation point" in its assigned band of frequencies. The new fields for the use of this young art which now appear regularly, clearly show that there is little chance of overtaking them with adequate channels for years to come.

The Monophone, therefore, proposes to put the telephone wires, now leading into millions of homes, to work sixteen hours a day in providing multiple program service. It must and does accomplish this without interfering with the regular point to point telephone service, or changing its present equipment in any way.

To indicate the electrical efficiency of this form of wired-radio, as compared with present space-radio, it may be stated that fifty watts of energy has been found adequate to saturate satisfactorily approximately 500 cable-pairs. A small and compact 5-watt transmitting unit for Army Signal Corps uses and for demonstration purposes throughout the country has been constructed. These units are capable of supplying somewhere in the neighborhood of 200 receiving sets.

The latest form of receiving set designed and constructed by the Kellogg Switchboard & Supply Company of Chicago comprises 3 tubes under a special circuit arrangement of their own design. The first tube is the new a.c. shield-grid

tube, with a power detector next, and 1 audio; this one audio tube has an undistorted power output of approximately 1½ watts, sufficient to operate a dynamic speaker. This makes a very compact set, one capable of giving good volume and very fine quality. There is no tuning required and the selection of one of the three programs available is made by simply throwing a switch or pressing a button. Volume control is provided. "Static" is eliminated, also the phenomena of "fading." There are no heterodyne effects, seasonal changes nor day-and-night variations which are inherent in space-radio. Television and sound moving pictures in the home, which are still in the laboratory, will find technical advantages in this particular form of wired-radio circuit.

Radio for Education

The United States Bureau of Education reports that at the present time there are twenty-five million children in American schools, and we are spending two billion dollars a year to support them. There are four million pupils in public high schools alone and over six hundred of these schools have more than 1,000 pupils each. This important element of our population is still waiting to be served by radio in a new way, never before possible.

The best minds from our state univer-

sities and colleges and the departments at Washington must be added to the teaching staff of our high schools through the development and perfection of chain broadcasting as a national educational function. This will result in elimination of waste in the present duplication of teaching staff, and reduce rather than increase the annual educational budget by dispensing with the inefficient teacher and raising the standard of the smaller staff then required.

In music we have our only universal language and its inspirational and cultural value during the formative years of youth in actually lifting our whole lives to a higher level can be now utilized as never possible before.

This outstanding national service cannot be financed through public advertising to increase the sale of commodities, but must be paid for directly by the people, as it should be.

The needs for new channels of communication require that ultimately both the telephone wires and the power wires into the home should be utilized in competition or co-operation.

The Super-University of the United States, for both youth and adults, can become, in the era ahead, the greatest educational and cultural institution in all history. Radio is the new agency by which alone this is possible.

CARLOAD CAPACITY with Test Tube Accuracy

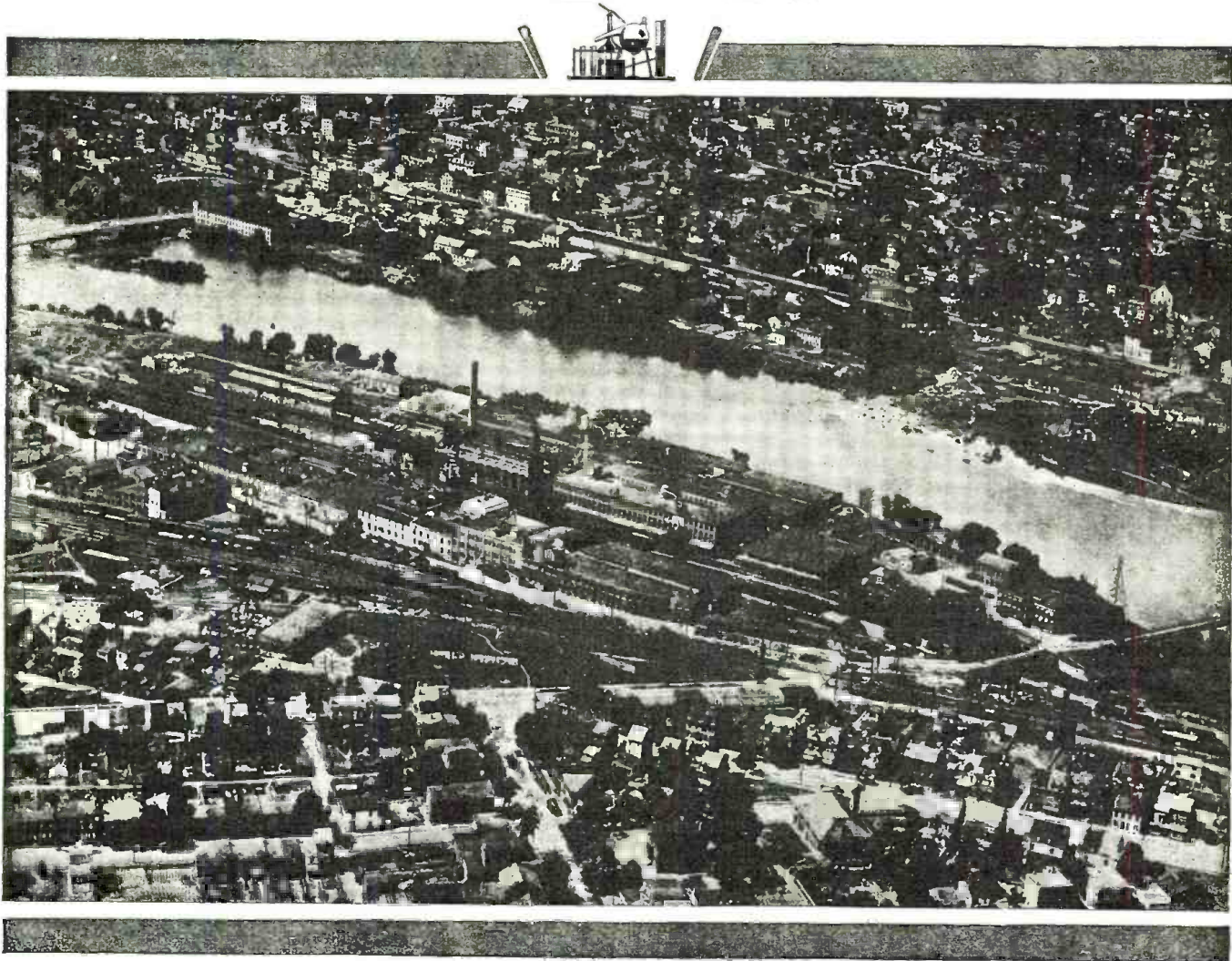

The Celoron Company's Plant at Bridgeport, Pa.

Celoron Products include:
Celoron Molding Powders; Impregnated Fabric and Paper for Molding; Synthetic Resins, Varnishes and Cements; Laminated Celoron sheets, rods and tubes for radio, electrical and industrial purposes; Celoron Silent Gears.

That is what the Celoron system of laboratory controlled production assures your business.

A better molding powder—it will improve the quality and salability of your molded products.

On time and right—it will help you to speed up production and to eliminate delays.

Always the same, throughout one batch, a carload, or an entire year's production

requirements—it requires no costly "experimenting" in the press room. It ensures uniform quality, fewer rejections, and allows a standardization of production methods most conducive to lowered manufacturing costs.

You can depend on Celoron. Why don't you?

THE CELORON COMPANY
Bridgeport, Pennsylvania
In Canada: 350 Eastern Avenue, Toronto



CELORON MOLDING PRODUCTS

PASSED by the NATIONAL BOARD of FIRE UNDERWRITERS



Good Buys in "B" Battery Power
100-Volt Edison Element, Non-Destructive, Rechargeable "B" Battery with charger. Shipped dry, with solution, \$12. 140-Volt with charger, \$17. 180-Volt Power Unit with Trickle Charger, \$24. **SEND NO MONEY—PAY EXPRESSMAN.**
Write for our Free Literature

SEE JAY BATTERY CO
915 BROOK AVE NEW YORK



Surveying at Home
Thousands needed for subordinate positions on survey parties by Federal, State and City government. Learn this interesting work by home study in 6 months. Complete tuition fee \$25. Pay only \$10 on enrolling.

The Civil Engineering Inst., World Bldg., Park Row, N.Y.C.

Send for WESTERN RADIO
New 1929 Catalog

LATEST and FINEST nationally known A.C. sets, consoles, cabinets, speakers and accessories at LOWEST PRICES. Catalog sent FREE on request.

WESTERN RADIO MFG. CO.
128 W. Lake Street, Dept. RN-7, Chicago

Whatever Your Resistance
Needs May be
Rely on ELECTRAD
Write Dept. RN-7 for data
175 Varick St., New York, N.Y.

ELECTRAD

7 TUBE SUPERPHONIC RADIO \$16.95
An amazing value that can't be beat! Latest 7 tube tuned radio frequency circuit. Send for complete descriptive circular.

RADIO EQUIPMENT CO.
4611 N. Clark St., Dept. 12-G, Chicago

SCIENCE and INVENTION
JULY ISSUE
Now On All Newstands

**Watch for August Issue:
Some of the Leading Articles**

"Financial Independence"
How to obtain it.
By John J. Raskob

"The Invisible Incendiary"
Scientific Fiction

"Time, Space and Relativity"
By Dr. Donald H. Menzel

How to Build a Simple Man-Carrying Glider
By George Gerber

Gravitation Electrically Controlled
By Thomas Townsend Brown
—The man who did it.

Building Your Own Outboard Motorboat
By William F. Crosby

25c
THE COPY

EXPERIMENTER PUBLICATIONS, INC.
381 Fourth Ave. New York, N. Y.
On sale on all newsstands, or write direct

Radio Forum

(Continued from page 70)

small antenna, but the volume of the broadcast program will also be decreased.

Another disturbing element present at times in most sets when receiving a distant station is *fading*. The phenomenon of fading is being thoroughly investigated by many engineers at this time, and considerable data has been obtained regarding its behavior. By the use of a powerful receiver, capable of receiving the desired program when the signal is at its minimum intensity, it is possible to incorporate a device whereby the sound level may be automatically controlled, thus eliminating the variation caused by fading. Several methods have been used to accomplish this end. Probably the simplest and most satisfactory method is to control the bias voltage on the radio-frequency amplifier by means of an extra tube connected so that any change in its plate current results in a change of bias for the r.f. amplifier stages. This method is being used on several receivers now being manufactured and is proving quite satisfactory. (The reader should note that in this issue of RADIO NEWS, in the article by R. E. Lacault, such a volume control system is described in detail.—*Editor.*)

Among the man-made causes of interference are:

- Electric flashing signs
- Household devices
- Street cars
- House-lighting systems
- Violet and X-ray machines
- High-voltage lines
- Farm-lighting systems
- Broadcast stations
- Regenerative receivers

ELECTRIC FLASHING SIGNS—Intermittent contact in the light circuits of electric signs usually cause a disagreeable click to be heard in the receiver. Of course, the offending sign may be detected by watching the different electric signs close by and noticing when the interference begins. Once the sign has been located, the interference can usually be stopped by connecting a one-microfarad by-pass condenser around the flashing mechanism. However, if the sign is run by a motor it will be necessary to connect two by-pass condensers in series across the motor, and ground the midpoint. See Fig. 5.

HOUSEHOLD DEVICES—Household devices such as electric fans, hair dryers, small motors, etc., will cause a rough buzzing noise to be heard in the set. These devices, however, seldom produce interference unless they are located close to the receiver. Treat this type of interference as you would any other motor.

STREET CARS—Electric street cars present a problem for which no really satisfactory solution has been found. This type of interference may be detected by a peculiar rather high-pitched humming noise that gradually increases and decreases as the car approaches and then passes by the location of the receiver. About the only way to decrease this type of disturbance is to erect the antenna at right angles to the trolley wire and as far away from it as possible. Efforts are being made to alleviate this condition by keeping the rail bonding in good shape and giving more attention to the car motors.

HOUSE LIGHTING SYSTEM—As a test for interference from this source, the supply switch should be opened for a moment. If the interference disappears with the opening of the supply switch, it is very evident the source of interference is in the lighting system. All lights and electrical apparatus should then be checked for defects. Sometimes a loose lamp in its socket will cause considerable disturbance.

VIOLET RAY AND X-RAY MACHINES—These machines cause a form of interference that cannot be stopped as long as the machines are in operation, unless the owners of such machines are induced to install suitable filters, a number of which are now available. However, these machines are seldom used except during the daytime, so this disturbance is very seldom serious in nature.

BATTERY CHARGERS—Battery chargers of the vibrating type will often cause interference if they are close by. This can be identified as a continuous rough buzzing sound caused by the sparking at the contacts at the make and break of the circuit. A one microfarad condenser connected across the contacts will usually correct this type of disturbance. A few cases have been found where the arrangement shown in Fig. 5 was required to completely eliminate the noise.

HIGH VOLTAGE LINES—High voltage lines may cause a continuous humming noise in the set. It may not always be possible to eliminate this disturbance entirely, but it can be greatly reduced by placing the antenna at right angles to the wires and as far away from them as possible.

MOTORS AND GENERATORS—Motors and generators operating in the vicinity of the set cause a humming noise when the brushes are improperly adjusted or become dirty. Most cases may be corrected when treated as shown in Fig. 5; however, an obstinate case will sometimes require a choke coil in the line as shown in Fig. 4.

FARM LIGHTING PLANTS—Farm lighting systems emit a characteristic click, corresponding to the ignition spark, which identifies this type of interference immediately. This can usually be eliminated by connecting two, two microfarad condensers in series across the D.C. line with the midpoint grounded to the frame. See Fig. 5. A few cases may require a choke in series with the line as shown in Fig. 4.

BROADCASTING STATIONS—Broadcasting stations operating on the same or nearly the same wavelength will cause a heterodyne whistling noise caused by the beating together of the two stations' carriers. This is a fault of the transmitting stations and cannot be corrected at the receiving end. Cases such as this will be found more on the lower wavelengths. Complete elimination of heterodyne whistles is a goal that is being earnestly striven for by the Federal Radio Commission which is working on this problem in collaboration with many prominent engineers.

REGENERATIVE RECEIVERS—A regenerative receiver located nearby will cause bird-like whistles of varying tones and intensities as the offending set is tuned. This is caused by a receiver being so adjusted as to radiate a small amount of power out into the ether.

This type of interference is gradually diminishing as people learn to sensibly operate their sets or as non-radiating sets are put in their places.

The above covers the most important sources of interference commonly found that originate outside of the radio set. However, as more and more new electrical devices appear on the market the above list will need a few additions, but from the above it is hoped that the embryo service man may grasp the fundamentals that cause radio interference, thus enabling him to handle new situations as occasion demands.

Disturbances within the set may be due to any of the following causes: Defective or microphonic tubes, dirty tube contacts, loose or corroded connections, defective batteries, defective speaker, noisy power transformer.

The tubes should be replaced one at a time with tested tubes to determine whether the tubes are defective. Oxidized tube contacts as well as the spring contacts on the sockets are the source of much trouble. These should be cleaned with a piece of fine sandpaper.

A loose antenna or ground connection will give rise to disagreeable crackling noises when shaken by the wind.

Loose or corroded connections are a source of bad clicking noises. Any copper wire which is exposed to the atmosphere oxidizes and this may cause poor contact, therefore make sure that the antenna and ground leads are soldered. Sometimes the soldered connections are not perfectly made; due to insufficient heating the solder will not flow over the wire although the rosin will hold the joint. This is called a "rosin joint" and produces a defective contact.

Defective batteries or defective battery connections are often the source of unnecessary noise. A defective "B" or "C" battery may cause a squeal or clicking interference. When the voltage drops to about 20 per cent of the normal rated value the block should be discarded. The voltage may be satisfactory when measured without load but due to a high resistance cell in the battery it will be useless as far as good reception is concerned. A defective "A" battery evidences itself with a flickering of the tubes or when they are not burning with full brilliancy.

A loudspeaker with a defective winding will also cause disagreeable noises. In the cone type speakers the armature may be hitting the pole pieces when music is being received. This will result in a buzzing sound and may be remedied by re-aligning the armature and tightening the screws that hold it in place.

Electrically operated sets of the a.c. variety will often pick up any disturbances on the line, especially if the power transformer has no electrostatic shield. Manufacturers are using electrostatic shields more and more, so this type of disturbance will decrease as the art progresses. However, a simple method that quite satisfactorily eliminates quite a lot of the line disturbances is to connect two one-half microfarad by-pass condensers in series across the line and ground the midpoint. Of course the condensers must be rated high enough to withstand the a.c. voltage being used. This has proven very satisfactory in many cases.

(Continued on page 80)



They Could Hardly Believe Their Own Ears...When I Switched to Ground Wave Reception!

"It's no use trying to listen in tonight," said Bill as I took his hat. "Jane and I tried to get reception during dinner but all we got was static. It's usually this way—just the night they broadcast Paul White-man's band or some other good program it's spoiled by howls and fading."

"Perhaps my set will do a little better," I suggested. I had a surprise in store for him!

He looked doubtful as I turned on the set switch. I had left my old aerial antenna attached on purpose and soon the room was filled with an ear-splitting excuse for music. Manipulation of the dials only served to make it worse. Occasionally it faded out altogether. Then the howls would start up again until my wife finally shouted, "Turn that thing off—it's terrible."

Satisfied, I laughed and disconnecting the old aerial and ground wires I then attached the lead-in wires of my new underground antenna, which I had installed just before dinner. "Now listen!" I commanded.

THE THRILLING TEST

As though by magic, the sweet high notes of violins and the stirring sobbing of saxophones brought Bill to his feet! Jane looked dumb-founded. The static was so greatly reduced that we hardly noticed it! We were getting one of the year's best programs with scarcely any trouble on a wild, stormy night.

"You see," I explained later to Bill. "I buried my new underground aerial about two feet below the ground, where wind and storms can't affect it so easily. They call this thing "Subwave-Aerial" and it's insulated some way to keep out interference and noise. It's combined with a scientific ground, so I'm sure now that I have the correct ground connection. All this isn't costing me any more than my old aerial antenna. And I'll never need to touch it again. It's guaranteed for 25 years."

Hardly necessary to say that Bill went home with the name and address of the Sub-wave-Aerial manufacturers in his pocket.



Now YOU Can Test Subwave-Aerial FREE

SUBWAVE-AERIAL Gets DX Installed 50 Feet From 60,000-Volt Power Line

"On January 27, 1929, drove out near the Sanitary District power plant—stopped about 50 feet distant from 60,000-volt transmission line—dug a small hole, into which we dropped the Subwave-Aerial, attaching the lead-in wires first to a 5-tube Freshman, then to a single-dial Atwater Kent Model 35.

"We got St. Paul, Minn., and Toronto, Can., loud and clear—not the slightest interference from the 60,000-volt power line 50 feet away. It was impossible to get reception with an overhead aerial under the same conditions." Yours truly,

F. Bennett Smith,
Harry R. Jackson.

The above story illustrates the results for which the designers of Subwave-Aerial struggled for months. At last, enthusiastic reports such as this from Radio Experts reproduced here, proved that they had succeeded. Now you have a chance to prove the merits of this great new radio development for yourself. Make the thrilling test—it's fun! And if you are not more than pleased, the test won't cost you a cent. Be sure to send at once for all the interesting details on the development of Subwave-Aerial. Use the coupon NOW!

UNDERGROUND AERIAL PRODUCTS,
Suite 618, St. Clair Bldg.,
Dept. 827-K.W.
St. Clair & Erie Sts.,
Chicago, Ill.

UNDERGROUND AERIAL PRODUCTS,
Suite 618, St. Clair Bldg.,
Dept. 827-K.W.,
St. Clair & Erie Sts.,
Chicago, Ill.

Rush illustrated literature on the new Subwave-Aerial and details of your Free Test Offer.

Name.....
Address.....
City.....State.....

\$5.50 buys this famous cabinet!

The Iveyline

Sizes range from 7 x 18 x 10 to 7 x 30 x 12. Mahogany finish, \$5.50 to \$8.75. Solid Walnut, \$6.50 to \$10.25. F.O.B. Hickory. Twelve-hour service. Write for Catalog.

Southern Toy Company
Manufacturer
Hickory, N. C.

SET BUILDERS
Get this Book

LATEST RADIO GUIDE FREE

Barawik, the first and oldest radio specialty house, offers you unusual service this year. Bigger stocks, quicker shipments, lower prices. Deal with an old established, reliable house. Get honest goods, honest service, honest prices. Barawik service makes you more money. Send now for big new Catalog showing lowest wholesale prices.

BARAWIK CO. 27-B Canal Sta., CHICAGO, U. S. A.
Mail This Coupon Now for Free Radio Guide

Name.....
Address.....

Insure your copy reaching you each month. Subscribe to Radio News—\$2.50 a year. Experimenter Publications, Inc., 381 Fourth Ave., N. Y. C.

PHONO Radio Consoles



STYLE R-53

For Radio or Phono-Radio Combination. A beautiful Walnut Cabinet with sliding doors of matched Butt Walnut. Ample space for Receiver, Speaker, and Phonograph equipment.

A descriptive bulletin of new 1929 styles sent free on request.

EXCELLO PRODUCTS CORPORATION
4832 West 16th St., Cicero, Illinois

Exide

RADIO BATTERIES

Manufactured by
THE ELECTRIC STORAGE BATTERY CO.
Philadelphia



Carborundum Detector

Improve your reception with the
Reg. U. S. Pat. Off.
Now It's Adjustable—used by noted circuit designers
THE CARBORUNDUM COMPANY
Dept. D-1 Niagara Falls, N. Y.

RADIO BARGAINS!

Used 5 tube sets, \$14.90. Guaranteed. A. C. Dynamic Speakers, \$14.75. B Eliminators, \$4.90. requires minor adjustments. Transformers, 75c. Condensers, 50c. Rheostats, 25c. Potentiometers, 35c. Vogue loop antennas, 95c. Crosley Cone Units, \$2.00. Fidelity Horn Units, \$1.90. Crystal Sets, \$1.75. 1 Tube Sets, \$1.75. Used 4 Tube Sets, \$3.90. Send money order with order. Complete list upon request. CHAS. HOODWIN CO., 4240 Lincoln Ave., Dept. 716, Chicago.

Dealers in Bankrupt Radio Stocks

AEROVOX Makers of high quality resistors and condensers that are Built Better — to endure. Write for The Research Worker. A free monthly publication. AEROVOX WIRELESS CORPORATION 66 Washington Street Brooklyn, N. Y.

Write for our latest Catalog "B-9," showing big savings in everything for Radio

ALLIED RADIO CORPORATION
711 W. Lake Street Chicago, Ill.

(Continued from page 79)

In the case of abnormal hum it is probable that the a.c. supply cord is directly under or in back of the receiver. If moving the lead does not alleviate this condition, the plug at the power outlet might be reversed with some improvement.

Many of the vacuum tubes used in present-day radio receivers are microphonic. This is specially true of detector tubes. Any slight jar or vibration will cause a disagreeable ringing noise in the speaker which can usually be stopped by clasping the hand over the noisy tube. Sometimes one tube is more microphonic than another and it is possible to eliminate the trouble by merely changing the offending tube to another socket. Of course a properly cushioned socket will often provide a remedy. Setting the receiver on a sponge rubber mat will also minimize the microphonic action of the tubes. If this does not eliminate the dis-

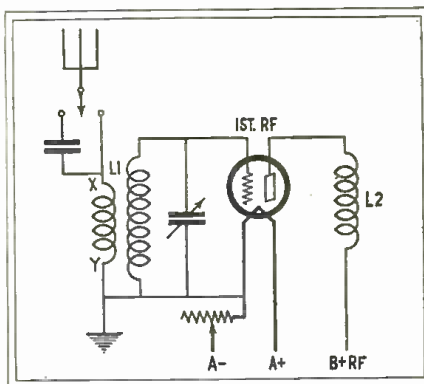

FIG. 6.

turbance it may be necessary to put the tube in an "anti-howl shield." This is simply a pear-shaped cover made of heavy rubber and fits snugly over the tube, thus damping out its vibratory action.

Remodelling an Old Set

ONE of the readers of RADIO NEWS has noticed that we have published information relative to remodeling old sets and has sent in the following information. This reader is Mr. Charles L. Brown, of Hallsville, Texas.

"I have made a few changes on a model NR45 Freed-Eisemann that improved the selectivity, R.F. gain and ease of tuning. This set uses the neutrodyne circuit with two stages of radio-frequency amplification, a detector, two audio amplifiers, the last stage having two tubes in parallel.

"The changes made are as follows: I removed the filament connections from one of the last audio tubes and connected the filament of this socket on the R.F. rheostat, which is the volume control on the set. Next, I disconnected the primary leads of the aerial coil, from aerial and ground posts, discarding the .00025 mfd. condenser. The plate of the tube socket was connected to one end of this coil and the other end was connected to 'B+ R.F.' I placed a choke coil between the grid of this tube and the '—A' and grounded the '—A.' The grid of the tube was connected directly to the aerial.

"These changes provide an additional untuned R.F. stage, causing the three dials

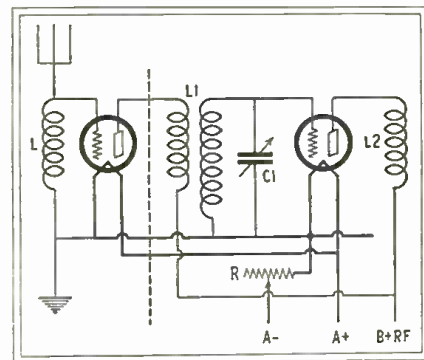

FIG. 7.

to 'keep in line' over the complete band. It also makes the first dial much sharper in tuning than before and increases the volume to some extent. The only extra part needed is the radio-frequency choke coil, which can be wound at home if desired. A suitable coil can be made by winding 350 turns of No. 26 wire on a tube 1" in diameter. The wire may be wound jumble fashion in order to conserve space.

"The accompanying diagrams, Figs. 6 and 7, show the changes. The two points 'X' and 'Y' in the first diagram are disconnected from the aerial and ground, and 'X' is connected to the plate of the new R.F. tube; 'Y' is connected in turn to 'B+ R.F.' The grid circuit of the new radio-frequency tube is connected to the choke coil which was described above, and the aerial and ground are connected to each side of this choke. The dotted line shows the addition of the extra amplifier tubes. Due to the construction of the set, the last tube sockets are only a few inches from the radio-frequency socket, and this permits the use of very short leads."

Interesting Booklets

MANY manufacturers of radio apparatus publish, from time to time, booklets which are of particular interest to dealers and service men. Many of these books are distributed free of charge and a dealer may obtain a number of them for his customers if he desires to do so. Among the interesting pamphlets for the service man which have been issued within the past few months are those listed below.

Cunningham Tube Socket Book—E. T. Cunningham, Inc., 370 7th Ave., New York City, N. Y.

Meters for Radio—Burton-Rogers Company, 26 Brighton Ave., Boston, Mass.

Transformer and Impedance Data—Samson Electric Company, 227 Washington Street, Canton, Mass.

Plate Supply Systems—American Transformer Co., 178 Emmet St., Newark, N. J.

Using Chokes—Samson Electric Company, 227 Washington Street, Canton, Mass.

A.C. Tube Operation—Thordarson Elec. Mfg. Co., Chicago, Ill.

The Custom Set Builder—Clark & Tilson, Inc., 122 Chambers St., New York City, N. Y.

The Use of Electrical Meters—Weston Electric Instrument Company, Newark, N. J.

Power Unit Problems—Electrad, Inc., 175 Varick Street, New York City, N. Y.

Distortion and What Causes It—Allen Bradley Company, 286 Greenfield Ave., Milwaukee, Wis.

What Set Shall I Build?—Herbert H. Frost, Inc., 160 N. LaSalle St., Chicago, Ill.

These booklets have been prepared by the various manufacturers in order to supply technical information of interest to those using their apparatus. They create an interest both in the construction and operation of sets and make the parts sold by these companies more widely known. They contain much valuable information for people technically inclined. Besides these pamphlets there are a number of periodical folders which are distributed by some manufacturing concerns. Among these periodicals are the Radio Builder, published by Silver-Marshall, Inc., 846 W. Jackson Blvd., Chicago, Ill.; The General Radio Experimenter, published by General Radio Company, Cambridge, Mass.; The Aerovox Research Worker, published by the Aerovox Wireless Corp., 70 Washington Street, Brooklyn, N. Y.; Raytheon Technical Bulletin, published by Raytheon Mfg. Company, Cambridge, Mass., and several others. We believe that these pamphlets and bulletins would be of interest to every radio dealer and service man, and, as mentioned above, they can be forwarded directly to your customers.

The Velvetone-29 (Continued from page 17)

the secondary being connected to the power tube or tubes, as the case may be.

When the set is completely assembled and wired, all that it is necessary to do is to line up the condensers for maximum reception at the lower end of the dial by means of the trimmers to compensate for differences in capacity due to the wiring. Connect the set to a short antenna, say twenty feet long, and tune in some weak station on the low wavelengths. Should the set tend to oscillate, change the screen-grid tubes around, as the a.c. screen-grid tubes which are at present available are not as uniform in their characteristics as the more widely used 201A. If there is only a slight tendency to oscillate, this may be eliminated by slightly decreasing the volume control. The lined-up condensers should then be slightly adjusted so that the weak station comes in the loudest or nearly so, and the receiver should then tune sharply all over the dial and have a tremendous amount of gain.

It is believed that the many radio fans who desire to build a set which combines distance and quality will be much pleased with the performance of this receiver.

LIST OF PARTS

The National MB-29 Kit comprises the following:

- 1 National chassis with five tube sockets
 - 4 National R.F. choke coils
 - 3 1.0 mfd. by-pass condensers
 - R1 1800-ohm resistor
 - R2 100-ohm resistor
 - R3 60-ohm resistor
 - R4 50000-ohm variable resistor, special taper
 - R5 20000-ohm resistor
 - 4 National special r.f. transformers complete with self-contained by-pass condensers and r.f. choke coils
 - 4 National type M variable condensers with zero adjustments
 - 1 National type F drum dial
 - 1 .001 mfd. mica by-pass condenser
 - 2 binding posts with insulating washers
- Wire, hardware, etcetera.

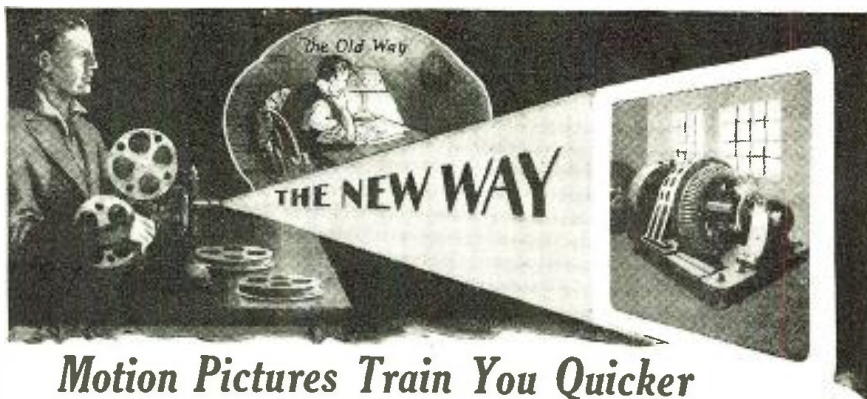

Motion Pictures Train You Quicker For a Big-Pay Job in ELECTRICITY



This motion picture method of home training is the very latest development. To compare it with the old style, book way is like comparing the 150-mile-an-hour aeroplane with the old Pony Express.

Now—it's easy to get a better job with bigger pay. Everybody agrees that ELECTRICITY is today's biggest field of Opportunity. And here is an amazing way to sure success in ELECTRICITY.

Now you learn from MOTION PICTURES right in your own home. You get a \$75.00 DeVry motion picture machine with details. Our big Free book tells you just how we train You for a better job. You'll be surprised at the startling facts. Mail coupon NOW.

Thousands of trained men needed. \$60.00 to \$150.00 a week is common. You take no risk. We guarantee in writing to give you the training necessary to get a better job or you need not pay a cent.

**Write Now for
Big Free Book**

It costs you nothing to get full details. Our big Free book tells you just how we train You for a better job. You'll be surprised at the startling facts. Mail coupon NOW.

**The NATIONAL SCHOOL of
VISUAL EDUCATION**

"The Film Way to Bigger Pay"

Take the Film Way to Bigger Pay

THE NATIONAL SCHOOL OF VISUAL EDUCATION
537 S. Dearborn St. Chicago, U.S.A. Dept. 7-N
Send book "The Film Way to Bigger Pay" with facts about this new, easier way to master electricity.
Name _____ Age _____
St. or R.F.D. _____
City _____ State _____
Mail This Coupon

Any A. C. Socket Power Set can be used on D. C. supplies—
if an "ESCO" Motor Generator or Dynamotor is used

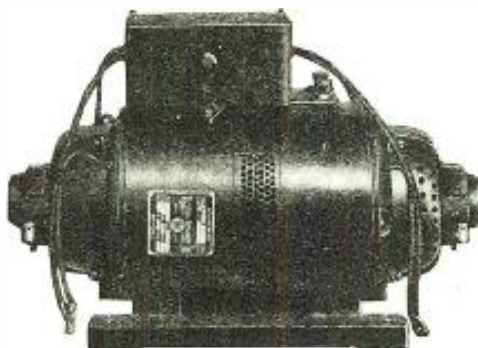

Motor Generator with Filter
For Radio Receivers

Machines for operating 60-cycle A. C. Radio Receivers, Loud Speakers and Phonographs from Direct Current Lighting Sockets Without Objectionable Noises of any Kind.

The dynamotors and motor generators are suitable for radio receivers and for combination instruments containing phonographs and receivers. Filters are usually required. The dynamotors and motor generators with filters give as good or better results than are obtained from ordinary 60-cycle lighting sockets. They are furnished completely assembled and connected and are very easily installed.

These machines are furnished with wool-packed bearings which require very little attention, and are very quiet running.

Write for Bulletin No. 243-C.

ELECTRIC SPECIALTY COMPANY

211 South Street

Stamford, Conn., U. S. A.

TRADE "ESCO" MARK

Manufacturers of Motors, Generators, Motor - Generators,
Dynamotors and Rotary Converters for Radio and other purposes



CODE LEARNED EASILY AT HOME

Has Helped Thousands to Better Positions in RADIO AND TELEGRAPHY
Automatic Transmitter will teach you the Wireless or Morse Codes, easily, quickly and cheaply for your present or future opportunity in a pleasant profession. U. S. Army, Navy, radio schools and scientific institutions throughout the world use the OMNIGRAPH. A great interest-developing hobby. List your friends in every corner of the world. Interesting. Catalog, 5c.
OMNIGRAPH MFG. CO., 810 E. 39th Street, Dept. M3, Brooklyn, N. Y.

NEW NORDEN-HAUCK MODELS

**ARE
NOW READY**
Super Electrophonic
Shielded Super-10
Super Dynamic Speakers
Power Packs
Short-Wave Apparatus
Etc.

Write Today for New Literature

NORDEN-HAUCK, INC.
Engineers
Marine Building
Philadelphia, Pa.

X-L VARIO-DENSER

Increase Efficiency and Power of Receiver

X-L Products give accurate values and dependable service. Endorsed by radio engineers, designers and set builders and standard in all best known circuits.



Model "G" Vario-denser

Model "G" with grid clips made in three variable capacity ranges. Price each, \$1.50.

Model "N" has variable capacity, adjustable from 1.8 to 20 micro-micro farads. Price each, \$1.00. Bakelite insulated X-L Push Post, the most perfect binding post made. Plain or all standard markings. Price each, 15 cents.

Manufacturers of the X-L Link, the 100% Voltage Control and many-purpose Light Socket Adapter.



X-L Push Post

Write for descriptive literature and free book of circuit diagrams.

XL Radio Laboratories
Dept. A, 1224 Belmont Ave., Chicago, Ill.

**MASON, FENWICK & LAWRENCE
PATENT LAWYERS**
600 F. St., N. W., Washington, D. C.
Estb. over sixty years. Send sketches.
Electrical, Aeronautical and Chemical Inventions carefully handled. Practice before the U. S. Courts and the Patent Office. Prompt and careful service. Write us.
TRADE MARKS REGISTERED

FREE Wholesale Radio Catalog
SEND FOR IT TODAY
Send for our new illustrated catalog of nationally known AC sets, kits, parts, accessories, consoles, etc. All lines at Lowest Wholesale Prices. Write for your FREE copy today.
SHURE BROS. CO.
Dept. 311 335 W. Madison St. CHICAGO, ILL.

Some Experiments on Ultra-High Frequencies

(Continued from page 59)

resonance, and C10 and C11 adjusted until this stage may be tuned through resonance with the detector circuit without stopping the latter from oscillating. A maximum capacity of 30 micromicrofarads should be used in condensers C4 and C5 since condensers of great capacity will offer too much capacity coupling and will cause interaction between the two stages. After the two circuits are finally adjusted, it should be possible to place the detector on maximum regeneration point and then tune the radio-frequency stage through resonance without detuning or stopping the detector circuit from oscillating. The detector circuit should be calibrated and a careful curve drawn for each coil system. It will be found that the circuit will retain the calibration values indefinitely. Stations will come in at dial settings previously logged, thus avoiding "hunting" as experienced in other circuits. Variation of R6 does not affect the tuning. On the 6, 7 and 8-meter bands, it may be necessary to increase the detector voltage to approximately 60 volts in order to have full control of regeneration over the whole scale of each coil system.

It will be possible to receive certain stations on their second harmonic values. This, of course, cannot be possible where the skip distance takes place. WLL operates on 17,000 kilocycles and may be heard during daytime on 35,800 kilocycles. During daytime, the writer has received signals from the following:

Frequency	Station	Location
24,740	WQA	New York
26,350	NAT	New Orleans
26,400	RZ	Unknown
26,450	LSD	Buenos Aires
26,500	HJO	Colombia
26,540	FY	Syria
27,440	KLL	San Francisco
27,560	WGT	Porto Rico
27,740	WIV	New York
27,744	NKF	Washington
27,930	English Beam Station	Station
28,000	NKF	Washington
28,400	NKF	Washington
30,000	NKF	Washington
30,860	KEW	San Francisco
31,000	NKF	Washington
32,000	WTY	New York (Rough note. Not a true harmonic.)
32,120	NAA	Washington
32,300	NKF	Washington
32,700	NKF	Washington
34,000	NKF	Washington
35,000	WQC	New York
35,800	WLL	New York
35,910	NKF	Washington
36,040	KQJ	San Francisco
37,800	WDS	New York
38,500	NKF	Washington
40,000	NKF	Washington (Not heard on all schedules.)

NKF was received on fundamental frequencies, as given, while reception of other stations listed was accomplished on the second harmonic value of the main transmitting frequency. Tests from NKF were conducted at a distance of 2,000 miles, which gave good signal strength at 38,500 kilocycles, which shows that the skip distance played an important part for reception of the last-mentioned frequency.

An important feature was observed in reception of these stations—the steadiness of the signals. In fact, very little fading was ever observed.

The writer concludes by stating that the new receiver described in this article makes possible reception of frequencies from 23,000 to 40,000 kilocycles, which provides 1,700 available channels, each 10 kilocycles in width.

COIL DATA FOR THE PUSH-PULL RECEIVER

Coil No.	Band in Meters	Turns Antenna	Turns Grid	Turns Grid Det.	Turns Tickler	Dia.
1	80	6	21	21	6	2
2	40	4	13	13	6	2
3	36	4	7 3/4	7 3/4	4	2
4	20	3	5	5	4	2
5	15	2	3 3/4	3	3 3/8	2
6	12	2	4	4	4	1
7	10	2	3	3	4	1
8	8	2	2	2	4	1
9	6	2	2	2	4	3/4

GRID AND ANTENNA COILS FROM NO. 1 TO NO. 5, INCLUSIVE, ARE WOUND 18 TURNS TO THE INCH WITH NO. 22 ENAMEL-COVERED WIRE. TICKLER COILS ARE WOUND 4 TURNS TO 1/8 INCH WITH NO. 27 ENAMEL-COVERED WIRE. COILS NO. 6 TO NO. 9, INCLUSIVE, USE NO. 22 DOUBLE SILK-COVERED WIRE FOR ALL COILS. WIND THE TICKLER COIL CLOSE TO THE GRID COIL. FOR COILS NO. 8 AND NO. 9 SPACE THE TICKLER COIL FOR EACH ONE SO THAT THE DESIRED FREQUENCY RANGE IS OBTAINED.

"Hello Little America—New York Calling"

(Continued from page 28)

hear the Byrd operator say. 'Meinholtz, the Times wants you to hang up your telephone receiver so that they can call you on the telephone.' Needless to say, this long-distance request to place a local telephone call will stand a record for all time, for it would be a trifle too expensive for the public to be careless enough to leave their telephone receiver off the hook and be checked up on it by a long-

distance operator 12,000 miles distant. "Radio has advanced rapidly. Just twenty years ago on April 6 Admiral Peary stood at the North Pole, yet it was several months later, while the world was acclaiming Cook that he made his way to the most northern telegraph office at Battle Harbor, Labrador, and sent his never to be forgotten message to the New York Times, 'I have the pole.'"

Portable Short Wave Transmitter

(Continued from page 36)

In a permanent location it is inconvenient to talk into a hand microphone. A "studio" pickup which will transmit sounds that originate anywhere in the room is already in the possession of most experimenters. It is nothing more or less than a cone speaker, and its terminals are connected to the input of the speech amplifier. This arrangement makes the loudspeaker work backwards, or convert sound energy into electrical energy.

The speech amplifier is merely a two stage audio amplifier using fairly good transformers and almost any sort of tubes. It may be the audio part of the Portable Multiwave Receiver. As shown in the diagram. Fig. 4, the speech amplifier output goes through an ordinary transformer to the grids of the modulator tubes.

The modulator tubes are preferably the same type as the oscillator. One modulator tube works quite well. Two in parallel work very well indeed. Four would be still better, but a rather unnecessary and expensive refinement. The reason for more than one modulator tube

and five and fifty miles with a UX-210, much greater distances are often covered. When the outfit was first set up at West Point, fifty miles north of New York City, a 210 was used with a 300 volt storage battery for plate supply. The location—in mountainous country—was none too good, and the late spring weather was thoroughly bad. In addition, the set was a rugged portable rather than a low-loss wonder resting mainly on air. In spite of these things we worked stations in Brooklyn, N. Y. (50 miles); Oneta, N. Y. (120 miles); Pottstown, Pa. (120 miles); Auburn, N. Y. (200 miles); and Greenburg, Pa. (300 miles). Heising phone was audible at a couple of hundred

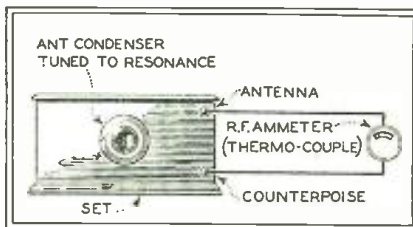

CIRCUIT USED IN OBTAINING THE OSCILLATOR OUTPUT TABLE SHOWN AT THE BEGINNING OF THIS ARTICLE



THE ANTENNA ERECTED AND READY FOR USE

is apparent when we recall how Heising modulation works. As far as audio frequency is concerned, the total current supplied to both oscillator and modulator is held quite constant by the choke, L6. The modulator, in accordance with the audio frequency voltages impressed on its grid, draws more or less current—acts as a variable resistance across the oscillator plate-filament. For complete modulation this variable resistance should equal the fixed resistance of the oscillator plate-filament. At normal grid bias, four modulator tubes in parallel draw about the same plate current as one oscillator.

Results

While this transmitter is conservatively rated at two and twenty miles with a 171

miles, but no verbatim phone reception was logged beyond Newburgh, ten miles away.

Then a 171 replaced the 210 for a few days' test, and the plate voltage was cut down to 100. The input was 2.7 watts, and the estimated output 1 watt. With this rather Lilliputian power we worked Newburgh easily enough; Riverside, N. J. (120 miles); Watertown, Mass. (175 miles); and actually disturbed the daylight ether at Lima, Ohio, 500 miles out—not bad for the 80 meter band. The 1 watt phone was heard weakly a hundred miles distant, but was not checked word for word beyond a receiver in Highland Falls, two miles away. In order to see how far the phone comedy would go, we put a UX-201A in the socket and cut the B battery to 40 volts. Highland Falls still got most of our conversation.

Its laboratory tests finished, the portable was at last ready for field and highway, lake and river. It was installed on the package rest behind the seat of a coupe, and fed by the car battery and a 90 volt B battery. We then drove to an open place in the hills three-quarters of a mile from the receiving operator, and put up the umbrella antenna. Every word went through without difficulty, even when we started the car and drove slowly along the road.

The next test was on the Hudson River. The transmitter, an A battery, a 90 volt B battery and the umbrella antenna were crowded into a small rowboat. On most seagoing craft the radio installations are inadequate, but this one may be truly said to have been overradioed. Our phone signals were continuously understandable at West Point up to two miles, when both the strength and good nature of the rowers gave out. At the same time, Newburgh, at eight miles, copied our code and heard the phone.

As a final test of portability, the set

Dial Headquarters Announce

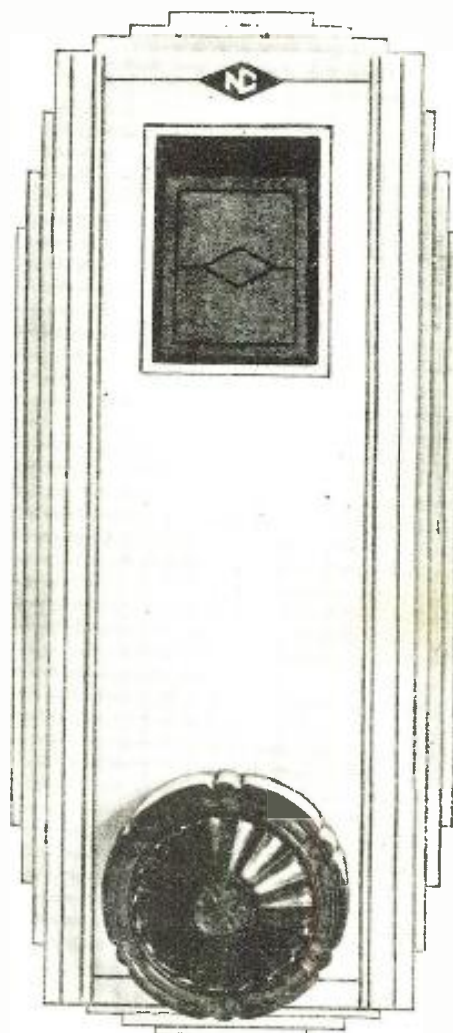

These new dials bristle with modern and ingenious features for your convenience and pleasure. Dial illuminator throws brightly colored image of scale on ground glass screen in dial opening, so that scale reads same from every position. The color changes automatically for different parts of the scale. Has beautiful modern escutcheon, brush silver finish. Model G operates disk scale, Model H is drum type—both using proved National Mechanisms.

Ask your Dealer to show you

NATIONAL VELVET VERNIER DIALS

Types G & H

or write us for Bulletin RN-133

NATIONAL CO., INC., MALDEN, MASS.

PROTECT your RADIO

USE THE

CORWICO

VULCAN

LIGHTNING ARRESTER

\$1



\$100 GUARANTEE

The Corwico Vulcan Lightning Arrester not only protects your radio set against lightning, but also dissipates accumulated static charges.

Any radio protected by a Corwico Vulcan Lightning Arrester that is damaged by lightning will be repaired by us up to a cost of \$100.

Why take chances with storms and lightning when you can have guaranteed protection for \$1.00.

Corwico Vulcan Lightning Arresters are sold by all dealers or directly upon receipt of price.

CORNISH WIRE COMPANY
30 Church Street New York City

MAKERS OF
CORWICO BRAIDITE HOOK UP WIRE

FIND HIDDEN GOLD

AMAZING NEW DISCOVERY. The genuine Spanish "GOLD DIGGER" Compass accurately locates hidden or buried Gold and Silver ONLY! coins, jewelry, treasure, etc. at unknown depths. Simple to operate. **SEND NO MONEY.** Buy Postman special installment price delivered. \$2.72 for Standard Type or \$3.21 for Double Strength Type for Professional Treasure Hunters and Prospectors. No additional postage, charges or duties. Thousands of satisfied users. Beware of imitations. Order immediately. **IT MAY MEAN YOUR FORTUNE.**

Interesting Proposition to Agents

G. B. BLAND, "APARTADO 1426," MEXICO CITY, MEXICO

We Will Pay

\$100 PER HOUR

to our agents for their spare time

You, too, can receive this big pay by soliciting subscriptions for our ten popular magazines. No trouble to sell. Beginners given help to get started.

Send for full information right now. Address

AGENCY DEPT.

Experimenter Publications, Inc.
381 Fourth Ave., New York, N. Y.

(provided this time with a 135 volt B battery) was placed in the car along with the receiver and driven seventy odd miles to Garden City. We expected on arrival to find all the nuts loose and half the tubes broken, but no such thing happened; both the transmitter and the receiver worked perfectly at the end of the trip. We did some satisfactory two-way code and phone work up to two miles with 2GY, Radio Broadcast's station, and with 2VM at Mitchel Field. Then we drove south to Long Beach, and set up close by the restless Atlantic. At about ten miles we worked perfect communication for an hour with 2GY, using code at first and then, to our surprise, phone.

So much for the story of the 80 meter portable transmitter—a long story, perhaps, but not without a certain amount of meat. The set will not raise Australia in the small hours, nor will it pump every last microwatt of energy into the antenna. But after banging around in a boat or car it will do its modest two and twenty without complaining. And that, after all, is what a portable is for.

Twenty-Four Hours With a Short-Wave Receiver

(Continued from page 41)

food and finally it came in. Never did a cup of steaming hot coffee look any better. And those rolls, surely an angel had made them. We were soon warmed up, refreshed and ready to go on.

The morning proved rather uneventful. We got plenty of stations, but the pile of stuff we had been receiving for the last twenty hours had proved the things we wanted to know. And we were ready to pile into the car, hurry home and tumble into our bunks. Which we did.

Results? We found that a pretty good coverage can be made of this old globe with a good short-wave receiver. A little coil changing is a great help. And we were grateful for the ability of this National set to break the monotony at times with some broadcasting music. The receiver was a joy to handle. Twenty-four hours working at pretty constant tuning will usually show up any weaknesses that are going to prove irritating on a job. The simple single dial control, smooth regeneration and plenty of kick so that too fine a regenerative point need not be reached, all helped in making the test a much easier affair than similar things we have tried with the old type receivers.

We found the job gave us real quality, so that the listening was not merely confined to logging and then going on. And finally, it proved that food and hot drinks are very important radio accessories, particularly when a long stretch of listening is planned, and that in some extreme cases, an application of whipped cream is necessary to get results.

A Correction

In the description of the *New York Times* short-wave receiver, which appeared in the May issue, an error occurred in the specifications for the shields. These shields are the Hammarlund box shields, type HQS, and not the HQS-1, as specified. This will cause some difficulty in the construction of the set unless the correct shields are used.

A Tube and Set Tester for a Lean Purse

(Continued from page 48)

The list is submitted as a guide for those wishing to service all kinds of sets.

- 1 adaptor, UX to UV-201.
- 1 adaptor, UX to UV-199.
- 1 adaptor, UV-199 to UX.
- 1 adaptor, UY to UX, extra terminal for test cord on K.
- 1 adaptor, UY to UX, extra terminal for test cord on K and H—.
- 1 D.C. ammeter, 0-5 amps.
- 1 book, loose-leaf, tube chart, notes and circuit diagrams.
- 8 clips, spring connector.
- 1 cord, 4", pin-tip both ends.
- 2 cords, 8", pin-tip both ends.
- 2 cords, 8", pin-tip and spade tip.
- 2 cords, 8", spade-tip both ends.
- 2 cords, 60", pin-tip and spade-tip.
- 1 cord, 60", spade-tip both ends.
- 2 files, 5", flat, 1 handle
- 1 flashlight, Ray-O-vac, 1½ volt.
- 1 knife (electrician's).
- 1 pencil.
- 4 pin-tips (screws and thumbnuts).
- 1 pliers (long-nose and side-cut).
- 1 pliers (square-nose and side-cut).
- 1 plug (light socket service tap).
- 1 plug ('phone).
- 2 plugs, G. & P. tube prongs with lugs attached.
- 2 plugs, fil. tube prongs with lugs attached.
- 1 single head 'phone, 2200 ohms, with 18" cord and pin-tips.
- 1 rheostat. Pilot resistograd, 0-3 megs., with lugs for attaching to tester panel.
- 4 sandpaper sheets. 3½ x 6".
- 1 screwdriver, ⅛" x 1½".
- 1 screwdriver, ¼" x 4".
- 1 screwdriver, ⅛" x 4".
- 1 roll friction tape.
- 1 A.C. voltmeter, 7½ volt (UX tube-base plug-in).
- 1 A.C. voltmeter, 150 volt (service tap plug-in).
- 50 feet wire, No. 24 D.S.C.
- 4 wrenches, flat, assorted (in leather case).
- 1 Spintite socket wrench.
- 1 cloth pad to protect wiring.
- 2 grid leaks (spares).

Following is list of parts necessary for construction of test set, including accessories, and price of each as catalogued by a prominent radio supply house:

- 1 box, old Radiola III, or home made
- 1 handle for box, about 3" long .10
- 2 butt hinges, ½" x 1"..... .10
- 4 rubberhead nails, from Radiola III, or buy at..... .10
- 1 panel, rubber, to fit box..... .57
- 1 voltmeter, Jewell Pat. No. 135, 0-8-200 D.C., without pushbutton..... 5.40
- 1 potentiometer, Carter MW-6-M, 6000 ohms, for R.... .73
- 1 dial, 2", rheostat..... .21
- 1 switch, SPST, midget knife— for X..... .09
- 1 switch, SPDT, midget knife— for LO-HI..... .15

(Continued on page 87)

Wenstrom's Multiwave Receiver

(Continued from page 39)

below the panel top. Some bus bar is used to steady the coil socket, and the series fixed condenser is held by bus bar just behind it. The shorting switch S. of the midget knife type, is screwed directly into this condenser. At the top center of the panel are the antenna and ground binding posts. The dials are mounted on the front of the panel, and the right one, controlling the tuning condenser, is a vernier.

In the center section and 8½ inches below the panel top is mounted the gang socket. Few if any radio stores carry it in stock. It is the "Frost No. 616 3-gang shock absorber socket for UV-199 tubes," and can be obtained from Herbert H. Frost, Inc., Elkhart, Indiana. In the middle of the center section is the voltmeter, to the right is the rheostat, and to the left the potentiometer. The grid leak is behind the extreme left of the panel, and the grid condenser is held by bus bar just above the tube socket. The radio frequency choke is held by bus bar just under the socket. The three phone jacks are placed one at each end of the gang socket and one just under its center.

The two audio transformers occupy most of the bottom section. Old style Amertrans were chosen for their high gain, small size and light weight and also because they happen to be on hand. Others of good make may naturally be substituted. Between the transformers is the filament switch: and below it is the external A battery jack, to which fahnestock clips for the internal A battery are soldered. All the other internal binding posts (fahnestock clips) are bolted to the bottom edge of the panel, and the two outside ones are also external posts. Behind the panel outside the transformers are the plate and grid by-pass condensers for the power tube, and its grid biasing resistance is held by bus bar below the left transformer. All wiring should be done in definite steps: first the filament circuits, then the various grid and plate circuits in order.

The carrying box is built of ½ inch white pine, nailed together with brads, reinforced with brass corners, and fitted with a suitcase handle. The lumber is cut as follows: 1 piece 12" x 14" (back), 2 pieces 6" x 13" (sides), 2 pieces 6½" x 12" (top and bottom), one piece 12" x 13" (front). The front is fastened to the rest of the box by snap catches, and when in place completely covers the panel. The back of the panel is held 1⅜" behind the inside of the front cover by two thin wooden stops at the bottom, and at the top by wing nuts on two bolts set in iron angles. The two B batteries are at the back bottom corners of the box, and the two A batteries are against the center of the back. All batteries are held in place by brass angles. Two plug-in coils are clipped into the back top corners. The entire carrying box is finished with walnut varnish stain. The phones could be crammed between the panel and the front cover, but few users will care to give them or the panel this sort of punishment.

Operation

When the set is completed, it should be thoroughly tested in the workshop

before any outside work is attempted. The operation and calibration of this receiver is practically the same as that of any standard regenerative circuit. First of all, connect the internal A battery for a test of the filament circuit and controls. Then connect the internal B battery and test each coil for even oscillation throughout its range. At this stage a few signals should be heard on the 40 meter coil without antenna or ground. Next plug in the external A battery and again test the filament controls. Finally, with antenna and ground connected, test each coil for actual reception and calibrate it.

To test the power tube connections, remove the two jumpers, change the 199 in the last socket to a 120, and plug a small cone speaker into the last jack. Then connect the external B-C battery and tune in a strong signal, which should be reproduced with good quality at comfortable room volume. When any trouble develops the jack system comes in handy, for one can immediately localize the fault in detector, first stage or second stage circuits. There follows a complete list of parts used in the set. Other parts, electrically and mechanically similar, may be used, but their dimensions should be carefully checked against the available space.

LIST OF PARTS

- C1—Cardwell old type 350 mmfd. variable condenser;
- C2—Sangamo 250 mmfd. fixed condenser;
- C3—Cardwell old type 500 mmfd. variable condenser;
- C4—Sangamo 150 mmfd. fixed condenser;
- C5—Sangamo .5 mfd. by-pass condenser;
- C6—Sangamo 1 mfd. by-pass condenser;
- L1, L2 and L3—see coil table;
- L4—Silver-Marshall r.f. choke, type 275;
- R1—Tobe tipon grid leak, 6 meg. (label removed);
- R2—Carter midget potentiometer, 400 ohm;
- R3—DeJur rheostat, 30 ohm;
- R4—Ward Leonard vitrohms resistance, small size, 3,500 ohm;
- 1—Frost 3 gang socket (see text);
- 1—Silver-Marshall coil socket, type 515;
- 1—Hoyt midget voltmeter, type 541, 0-4 volts;
- 1—General Radio dial, type 302, 2¾" vernier;
- 1—General Radio dial, type 310, 2¾" plain;
- 2—Amertran transformers, type AF-6, 5-1;
- 1—Jack, open circuit;
- 2—Jack, double circuit;
- 1—Jack, filament lighting;
- 1—Filament switch, small push type;
- 4—Eby binding posts, large;
- 7—Fahnestock clips;
- 1—Grid leak mounting;
- 1—Bakelite panel, ¼" x 11" x 13" (see text);
- 1—Carrying box, complete with batteries (see text).

Portable Results

Recently some rather interesting tests were made with this receiver near West Point, 50 miles north of New York City. They extended over two or three eve-

Learn Electricity by Actual Work



Student Testing and Repairing Motor

In the Great Shops of Coyne

Complete Training in 12 Weeks Get into the BIG PAY FIELD. The whole world of Electricity is open to you as a COYNE-trained man. 12 weeks from now you can be a trained Electrician no matter what you are doing today. Make this the most profitable and enjoyable summer of your life. Come to Chicago on beautiful Lake Michigan, the Electrical Center of the world. I'll allow your Railroad Fare from any place in the United States! Clip Coupon Now for Full particulars and for Big Free Book.

Learn to Earn \$60 a Week and Up Coyne training is practical, money-making training — not correspondence. You work on the greatest outlay of Electrical Machinery in any school in the country, everything from Doorbells to Power Plants — everything to make you a thoroughly-trained BIG-PAY EXPERT.

No Advanced Education or Experience You don't need advanced education and it makes no difference what kind of work you are doing now. I'll make you a trained man through the COYNE LEARN-BY-DOING METHOD! I have done it for thousands — I will do it for you!

Aviation Electricity — Radio — Auto Electricity Courses and Railroad Fare Included — If You Enroll Now

I'll allow your Railroad Fare to Chicago, from any place in the United States if you act quick! And right now I am including absolutely free of extra charge, my complete Aviation, Electrical, Radio and Auto, Truck and Tractor Electricity courses. CLIP COUPON NOW!

We Are Specialists

We do not attempt to teach you several trades. We specialize in Electricity and nothing else. Have been teaching Electricity by actual work for 30 years.

Earn While You Learn

My Employment Department helps you get a job to earn a good part of your expenses and assists you to a good job on graduation.

Send Coupon NOW! Don't delay a minute — get my big Free Book and full particulars of my special offer.

COYNE ELECTRICAL SCHOOL
500 So. Paulina Street Dept. B9-27 Chicago

Mail For Free Book

Mr. H. C. LEWIS, Pres. Dept. B9-27
COYNE ELECTRICAL SCHOOL
500 S. Paulina Street, Chicago, Ill.

Dear H. C.: I sure want one of those Big handsome 12x15 books, with actual Photograph Reproductions. Send it quick. I'll be looking for it in the next mail. I want the facts without placing me under any obligation.

Name.....

Address.....

City..... State.....



ORDER NOW AND SAVE MONEY

Here are the popular magazines that live Americans are all reading and talking about. They are offered to you at these special summer bargain prices in order to keep our clerical force busy during our slow season. Take advantage of this situation and benefit through these generous savings by ordering subscriptions for these favorite magazines now.

OFFER NO. 1		
SCIENCE AND INVENTION with PLAIN TALK	}	
Single copy value\$7.20		
Both for only \$5.00	You save \$2.20	
OFFER NO. 2		
SCIENCE AND INVENTION with RADIO NEWS	}	
Single copy value\$6.00		
Both for only \$4.00	You save \$2.00	
OFFER NO. 3		
SCIENCE AND INVENTION with AMAZING STORIES	}	
Single copy value\$6.00		
Both for only \$4.00	You save \$2.00	
OFFER NO. 4		
SCIENCE AND INVENTION with COMPLETE NOVEL	}	
Single copy value\$6.00		
Both for only \$4.00	You save \$2.00	
OFFER NO. 5		
SCIENCE AND INVENTION with DETECTIVE NOVEL	}	
Single copy value\$6.00		
Both for only \$4.00	You save \$2.00	

OFFER NO. 6		
SCIENCE AND INVENTION with SCREEN BOOK	}	
Single copy value\$6.00		
Both for only \$4.00	You save \$2.00	
OFFER NO. 7		
PLAIN TALK with RADIO NEWS	}	
Single copy value\$7.20		
Both for only \$5.00	You save \$2.20	
OFFER NO. 8		
PLAIN TALK with SCREEN BOOK	}	
Single copy value\$7.20		
Both for only \$5.00	You save \$2.20	
OFFER NO. 9		
PLAIN TALK with COMPLETE NOVEL	}	
Single copy value\$7.20		
Both for only \$5.00	You save \$2.20	
OFFER NO. 10		
PLAIN TALK with DETECTIVE NOVEL	}	
Single copy value\$7.20		
Both for only \$5.00	You save \$2.20	

CLIP HERE AND MAIL PROMPTLY

THE low prices for these attractive magazine combinations will be withdrawn without notice, so protect yourself on these big savings and send your subscription order at once on the convenient order form opposite.

EXPERIMENTER PUBLICATIONS, INC.
381 Fourth Ave., New York City, N. Y.

Gentlemen: Please enter my order at the special summer bargain prices offered and enclosed find \$..... for the following magazine subscriptions. (Order by number as listed.)

Send Offers Nos.

To

Address

City State

Send Offers Nos.

To

Address

City State

Subscriptions will be accepted for United States and possessions only

RN 7-29

nings. There was no attempt to drag in extreme distance or to invoke the powers of the listener's imagination; we wanted simply to find out what the set would do under average conditions. As some signals had been heard accidentally in the laboratory while testing the set without antenna or ground, on the first test the two inch coil in the set was the only pickup. The set was placed on the high concrete wall of an athletic stadium up in the hills. On the broadcast coil, WEAF was tuned in intelligibly by zero beat. With the 80 meter coil in place KDKA came in quite distinctly on 62 meters, and amateur code came through from Connecticut and Pennsylvania. Then the 40 meter coil was plugged in, and brought in amateur code from New Jersey, Pennsylvania, New Hampshire, Virginia, North Carolina, Ohio and Indiana.

The set was next driven in a car to a location close to the first one, beside a reservoir in the hills. The car was the counterpoise, and the single wire antenna was strung out on a slight upward incline to a nearby wall. On the broadcast coil WEAF, WJZ and WOR of the New York area, as well as WGY of Schenectady and WOKO of Beacon, came through with faint loudspeaker volume. KDKA of Pittsburgh, WGIP of Hartford, WCAM of Camden and WCAP of Asbury Park were also heard, along with WNYC, WMCA, WGBS, WPCH and WABC of the New York area. On the 80 meter coil KDKA was up to fair loudspeaker volume; code amateur signals came in from Massachusetts, Delaware, Pennsylvania, Michigan, and Prince Edward Island, Canada; amateur phones in Pennsylvania and Long Island were clearly understood. The 40 meter coil was somewhat of a surprise. Amateur code signals came in from all over the United States: from Quebec, Ontario and British Columbia; from Mexico and Ger-

many; and from Cameroons and Liberia in Africa and a Portuguese ship. But this is not spectacular when we remember the carrying power of short waves, and particularly the carrying power of code.

The next test was made with the wave coil antenna to see what could be done with the car in motion. Of course there was some ignition noise, but on the broadcast coil it was not loud enough to obscure speech. On the 80 meter coil it was worse, so that only loud signals came through; and on the 40 meter coil it was very hard to hear anything but ignition noise. On the broadcast coil we tuned in WGL, a thousand watt station 50 miles away. Then the car was started, and at 20 miles per hour WGL still came through with a clearly understood weather report. After a few minutes of this, the local weather turned to distinctly overcast in the form of a tree limb which knocked the antenna off the car, but we put it back on and continued the test long enough to show that there is nothing difficult about broadcast reception in a moving car. Some interesting shadow effects can be visualized by noting the signal changes in hilly country.

The final test was made in a rowboat on the Hudson for a half hour in the late afternoon. The umbrella antenna was used, along with a small copper plate in the water for ground. WEAF, which in this vicinity might be called "Old Faithful," again came through with weak loudspeaker volume. WOR, WJZ, WABC and WNYC of the New York area came in clearly, as did WGY at Schenectady and WICP at Bridgeport. The short wave coils were not used in this test, but on the small antenna they would undoubtedly have done better than the broadcast coil.

These tests seem quite pleasing where we remember the simplicity of the set. Simple though it is, a more reliable and versatile receiver would be hard to find.

A Tube and Set Tester for a Lean Purse

(Continued from page 84)

1 switch, DPDT, midget knife— for A-V.....	\$.24	1 adapter, UV-199 to UX.....	\$.44
7 jacks, pin-tip.....	.42	1 tube base, UX-199, for plug AD.....
4 sockets, Pilot subpanel type, UX—for VT and adapters.....	.48	1 tube base, UV-201, for UX to UV adapter.....
1 socket, Pilot subpanel type, UY—for adapter.....	.12	1 tube base, UV-199, for UX to UV-199 adapter.....
4 binding posts, old nickelplate style, from Radiola III or buy.....	.20	1 tube base, UX-201, for UY to UX adapter.....
1 strap, short-circuiting, from Radiola III or home-made		1 tube base, UY-227, for UX to UY adapter.....
1 cable, 5 ft., 5 wire, from Ra- diola III or buy at.....	.50	1 rheostat, Pilot resistograd, for Ext. R.....	.59
25 feet wide, tinned hook-up, Braidite.....	.18	2 radio brackets, flat, for lugs to resistograd.....	.16
125 feet wire, silk-covered loop an- tenna wire for cords.....	.85	1 voltmeter, 7½ volt, a.c., UX plug-in base.....	1.47
10 plugs, pin-tip, Carter Imp plug.....	.90	Assorted screws, nuts and washers.....	.25
10 terminals, spade-tip, or improv- ise from soldering lugs....	.02	Note-book, loose-leaf, 3½" x 6".....	.25
8 clips, spring connector. Pee Wee.....	.20		
		Total cost.....	\$14.72

"Here at last is THE BOOK that we of the Radio profession have needed for a long time. It is the best and most complete handbook ever published," says J. H. Bloomenthal, Chief Radio Operator, U. S. S. B. Steamship "East Side."

THE RADIO MANUAL

A Complete Course in
Radio Operation
In a Single Volume

A Handbook
for
Students
Amateurs
Operators
Inspectors



For the first time an entire course of training in one book — the most complete and up-to-date work on radio. Developed simply and clearly from the elementary stage right through all phases of principles, practice, and apparatus so that a beginner with no knowledge of electricity may get all he needs either for amateur operation or to qualify for a government license as operator or inspector.

Prepared by Official
Examining Officer

The author, G. E. Sterling, is Radio Inspector and Examining Officer, Radio Division, U. S. Dept. of Commerce. The book has been edited in detail by Robert S. Kruse, for five years Technical Editor of QST, the Magazine of the Radio Relay League. Many other experts assisted them.

16 Chapters Cover: Elementary Electric-ity and Magnetism; Motors and Generators; Storage Batteries and Charging Circuits; The Vacuum Tube; Circuits Employed in Vacuum Tube Transmitters; Modulating Systems; Wavemeters; Piezo-Electric Oscillators; Wave Traps; Marine Vacuum Tube Transmitters; Radio Broadcasting Equipment; Arc Transmitters; Spark Transmitters; Commercial Radio Receivers; Radio Beacons and Direction Finders; Radio Laws and Regulations; Handling and Abstracting Traffic.

New Information never before available such as a complete description of the Western Electric 5-Kilowatt Broadcasting Transmitter; description and circuit diagram of Western Electric Superheterodyne Radio Receiving Outfit type 6004-C; Navy Standard 2-Kilowatt Spark Transmitter; etc.; etc. Every detail up to the minute.

Free Examination

"The Radio Manual" has just been published. Nearly 700 pages. Profusely illustrated. Bound in Flexible Fabrikoid. The coupon brings the volume for free examination. If you do not agree that it is the best Radio book you have seen, return it and owe nothing. If you keep it, send the price of \$6.00 within ten days.

Order on This Coupon

D. Van Nostrand Co., Inc.,
8 Warren St., New York

Send me THE RADIO MANUAL for examina-
tion. Within ten days after receipt I will either
return the volume or send you \$6.00, the price
in full. (Radio News 7-29)

Name

St. & No.

City and State

SHORT WAVES

without the expense of a new set!

The Submariner

WILL CONVERT YOUR RADIO SET INTO AN EFFICIENT SHORT-WAVE RECEIVER

Simply remove a tube from the set and place it in the "Submariner," then insert plug from "Submariner" in the socket from which tube was taken, attach aerial and ground to clips of "Submariner." Write for our money-back guarantee. Enthusiastic owners have written us from all parts of the world. Stations 8,000 miles away have been received. Vernier dial 32 to 1 ratio. Users are getting foreign stations the year around. There is very little static and short waves carry a much greater distance.

FOUR MODELS

20 to 65 meters for battery tubes, \$15.00. For all electric, \$17.50. Interchangeable coil model, 10 to 160 meters, \$22.50, for A.C. or D.C. receiver. No. 4 coil, 160 to 340 meters, \$2.00 additional. In ordering, be sure and state name of set and the number on each tube. Ask your dealer for one. If he does not carry them, he will get one for you.

If you are unable to get one locally, it will be sent postpaid upon receipt of money order or certified check. Sent C.O.D. only if \$1.00 accompanies order. This is to insure carrying charges. Price in Canada and some other foreign countries, 60c. additional. Cannot be sent C.O.D. outside U. S. **ORDER TO-DAY.**

J.-M.-P. MANUFACTURING CO., Inc.
3413 Fond du Lac Ave. Milwaukee, Wis., U. S. A.



Our Fifty-Dollar Prize-Winning Short-Wave Receiver

(Continued from page 25)

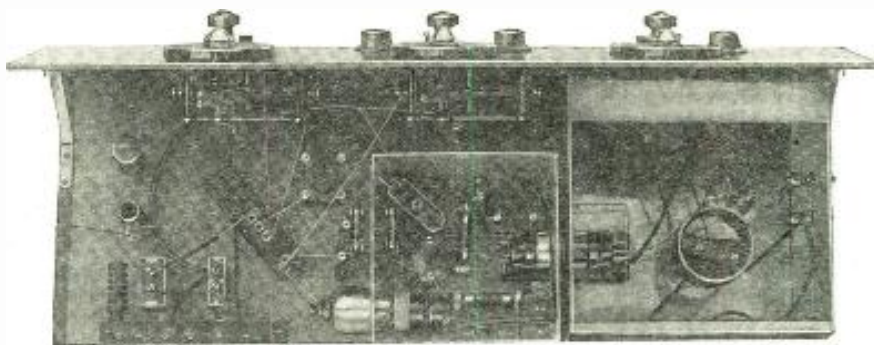

A BASEBOARD VIEW OF THE PRIZE WINNING SHORT-WAVE RECEIVER

the constructor can look forward to the possession of a receiver of outstanding merit and one which should fill him with pride.

LIST OF PARTS REQUIRED

- 2 aluminum or copper boxes of suitable size;
- 1 panel at least 25" long;
- 1 baseboard of length of panel by about 10" deep;
- 3 vernier dials (National, Karas, etc.);
- 1 set "Aero" International small diameter coils;
- 2 or 3 General Radio unwound formers;
- 1 General Radio coil base with jacks;
- 6 General Radio banana plugs;
- 1 "Aero" RF choke coil or home-made;
- 3 Benjamin floating UX sockets;

- 1 battery switch;
- 1 detector rheostat, 15 ohms;
- 2 "Amperites" No. 622.
- C1—Hammarlund Junior condenser, 65 mmfds.;
- C2, C4, C5—R.E.L., Karas, Cardwell or Pilot condenser, .00015 mfd., .00015 mfd., .00025 mfd.;
- C3—Hammarlund Junior condenser, 85 mmfds.;
- R1—Lynch or Durham 10,000 ohm resistance and mounting;
- R2—Lynch or Durham resistor, 7 megs.;
- R3—Lynch or Durham resistor, 10 megs.;
- R4—Sangamo fixed condenser, .0001 mfd. with clips;
- Flechthim or other .5 mfd. by-pass condensers;
- Quantity of busbar, screws, solder, etc.

ELECTRIFY YOUR RADIO FOR ONLY \$6.85



Why discard your present good set when you can electrify it for only \$6.85, and banish the annoyance and expense of buying new "B" batteries?



OVER 100,000 TOWNSEND "B" POWER UNITS IN USE
Hooked up in a few minutes. Use same tubes—no changes. You'll be amazed at the improvement in reception and distance getting. Send name and address today for full details, proof and Free Trial Offer.

TOWNSEND LABORATORIES,
725 Townsend St., Chicago, Ill.
Please send me full information on the Townsend "B" Power and Free Trial Offer.

Name
Address
City State

CONTROLS THE TRAFFIC THRU YOUR TUBES

Like the corner cop directing traffic, AMPERITE controls tube voltage. Self-adjusting, dependable, accurate. A type for every tube—A.C. or D.C. \$1.10 with mounting (in U. S. A.) at all dealers.

Radiall Company,
507 FRANKLIN ST., NEW YORK
FREE "Amperite Blue Book" of modern circuits and valuable construction data. Write Dept. RN7.

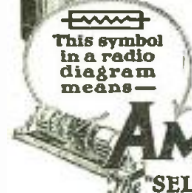

AMPERITE
REG. U. S. PAT. OFF.
The "SELF-ADJUSTING" Rheostat

"Balanced Unit" Radio for Faithful Reproduction

BRINGING with it the same controversial flavor as the old question as to whether the hen or the egg came first, is the argument as to whether today's fine radio programs are the result of good broadcasting or improved receivers or both.

One has only to compare the receiving sets sold but a few years back with a 1929 balanced unit set to get the startling contrast between the distortion and crudity of the old and the fidelity and precision with which the new set reproduces. Look at the scenery through a window-pane made of common glass and then look through a pane of the finest plate-glass and the contrast will be every bit as great to the eyes, as old and new radio sets are to the ears.

The first step on the long road from the crudity of early receiving sets to the perfection of the 1929 Balanced Unit Radio was made when radio engineers and the owners of radios realized that the perfection of Paul Whiteman's jazz or the beauty of a fine symphony orchestra was utterly dependent on the set through which it was received, that the most masterly music heard through an imperfect set became nothing but the blattings and groanings of the most amateur music making.

And now in the latest refinement of the radio engineer, the Balanced Unit Radio, we see radio receiving sets comparable to fine violins as a medium for

transmitting beautiful sound. Everybody knows that a fine program played by a Heifetz or a Kreisler on a famous Stradivarius would be very different if these great artists played on a crude instrument. But most people do not realize that the slightest maladjustment, even to a fraction of an inch of the many delicate parts of a violin can so alter and kill the tone of even a priceless violin that it becomes almost unrecognizable.

Radio engineers have proved that there is only one way to secure, without distortion, the programs put on the air by broadcasting stations, and that way is to build a receiving set where all the units in it are perfectly balanced and synchronized.

Distortion is bound to occur where induction coils, transformers, chokes and condensers are assembled into a set with little or no regard to their individual characteristics.

Every unit in a set has a certain individuality of its own and if this fact is not of paramount importance to the builders of a radio set the product will perform somewhat like a chorus in which each member is singing in a different key.

Radio sets in which the units are carefully balanced by means of delicate and complicated tests provide a straight path from the antenna through the set to the ear. Unbalanced units put hurdles and obstacles in the way and distortion and poor quality are the result.

SET BUILDERS Get this Book



Barawik, the first and oldest radio specialty house, offers you unusual service this year. Bigger stocks, quicker shipments, lower prices. Deal with an old established, reliable house. Get honest goods, honest service, honest prices. Barawik service makes you more money. Send now for big new Catalog showing lowest wholesale prices.

BARAWIK CO. 27-A Canal Sta., CHICAGO, U. S. A.

Mail This Coupon Now for Free Radio Guide

Name
Address

How to Build the Taylor Band Isolator

(Continued from page 32)

The method of wiring does not require explanation. It is suggested, however, that long leads carrying the "A" and "B" currents be run underneath the baseboard for the sake of appearance.

After the wiring has been completed the usual tests should be made to make sure that no connections have been omitted or incorrectly made. If everything checks up satisfactorily, the "A" and "B" supplies, amplifier, antenna and ground should be connected up. The shield covers may be left off for the time being. Now adjust the three midget condensers to a half-way position and turn the screws of the equalizers C15 and C16 all the way in, but the screw of C17 only half-way in. Then, with the volume control turned three-quarters up (clockwise) and with the plates of the midget condenser C3 unmeshed, tune in a station with the two main tuning dials. It must be remembered that at this point these two dials may or may not run alike, because the balancing condenser, C7, has not yet been adjusted. Nor is the signal tuned in likely to be loud, because the intermediate stages are thus far only tuned roughly to resonance.

If nothing is heard, turn the volume control up a little more and again tune through the entire scale slowly, being especially careful with the right-hand dial because of its extreme sharpness of tuning. It is safe to assume that a station will be heard this time. When it is, adjust the two tuning dials exactly. Then, leaving these two dials alone, adjust the three midget condensers, C4, C5 and C6, individually to exact resonance. Should it be found that one of the intermediate circuits cannot be brought into resonance due to lack of capacity, or too much capacity, in the midget condenser the circuit capacity can be increased or decreased by readjusting the corresponding equalizer condenser. It may be found that even with the midget and equalizer condensers in one of the circuits set for their maximum capacity that circuit can still not be brought to resonance with the others. In that case, turn the oscillator dial back one-half degree. This will raise the heterodyne frequency and thus raise the intermediate frequency. A resetting of the tuning condensers of the intermediate stages will then be necessary and it will probably be found that the three circuits

can now be brought to resonance. If not, repeat this procedure.

Having reached this point, the adjustment should be carried a little further so that resonance is obtained with the three midget tuning condensers meshed to the same degree. This is accomplished by readjusting the equalizer condensers to add or subtract capacity, at the same time keeping the circuit in resonance by readjusting the corresponding midget condensers. This is suggested because then the intermediate amplifier has a small tuning range which permits the selection of a frequency within this range which provides the best results. Finally, tune in a weak distant station and again test the intermediate tuned circuits for resonance, because it is sometimes difficult to bring these circuits to exact resonance when using signals from a local station, because of the great volume.

Now the shield covers may be fastened in place. This may alter the circuit capacity slightly, necessitating a final readjustment of the midget condensers. With this job finished the equalizer condenser, C7, is adjusted. For this purpose tune in a station at about 40 on the an-

RADIO DIRECTORY

Send for This

We have a new illustrated catalog showing our up-to-the-minute stock of kits, parts and sets — everything you want in radio — all at dealers' wholesale prices. Write today for Catalog "B-9."

ALLIED RADIO CORPORATION
711 W. Lake St.
Dept. "B-9," Chicago, Ill.

The Arc Aerial



An outside aerial that can be attached in 10 minutes — without climbing on the roof. Write today for details and price.

The Arc-Aerial, Inc.
Green Bay, Wisconsin

LOWEST PRICES



GREATEST VARIETY

Dealers, write for catalog.
W. C. BRAUN CO.
552-K Monroe St., Chicago



Moisture-Proof Extension Cords

Birnbach Extension Cords permit the Loud Speaker to be moved to any room in the house. Attaches instantly. Install a Birnbach Cord and put an end to distortion so often due to badly insulated cords. Your neighborhood dealer has these sizes in stock: 10-20-30-40-50-100 foot lengths. Send for Catalog.

BIRNBACH RADIO CO.
254 W. 31st St., New York

SEND FOR NEW RADIO BOOK

All the new hook-ups. Parts, supplies, A.C. sets, television, short wave, etc.

Write for free copy now.

The Barawick Co.

11-K Canal Sta., Chicago

The PACENT Super Phonovox

THE WORLD'S LEADING ELECTRIC PICK-UP
PACENT ELECTRIC CO., Inc.
91 Seventh Avenue, New York

LYNCH

Metallized RESISTORS

give absolutely noiseless, permanently accurate resistance. Higher quality, at no higher price. Sizes from .0005 to 10 meg. 50c up. For heavier duty, use Dynamic Type, 85c up.

ARTHUR H. LYNCH, INC.
1775 Broadway New York

200,000

RADIO NEWS readers carefully scan the RADIO DIRECTORY every month.

Your product here, at the lowest cost in the world's largest and most widely read radio magazine.

RATE PER ISSUE—\$25.00

No order for less than three insertions accepted.

Write for Information

RADIO NEWS, 381 Fourth Ave., New York City

RADIO NEWS DIRECTORY

The most complete catalog of AC sets, parts, accessories, etc. All nationally known at dealers' wholesale prices. SAVE MONEY. Write today for your FREE Catalog.

SHURE BROS. CO.
335 W. Madison St.
Dept. 312 Chicago, Ill.

The RADIO DIRECTORY is your buying guide. Space permits display of only one product at a time.

Write advertisers for complete catalogue.

SEND NOW for New 1929 WESTERN RADIO'S CATALOG

LATEST and FINEST, nationally known A.C. sets, consoles, cabinets, speakers and accessories at LOWEST PRICES. Catalog sent FREE on request.

WESTERN RADIO MFG. CO.
128 W. Lake St.
Dept. RNC7 Chicago

C. R. LEUTZ, INC.
Long Island City, N. Y.

Radio Receivers
"SEVEN SEAS"
"SILVER GHOST"
"PHANTOM"

Literature on request

Send 25 cents cash or stamps for 64-page Power Amplifier Manual describing all A. C. and D. C. amplifiers for all tubes. Including the new 245 tubes just out.

Name

Address

State

Rawner Radio Co.
142 Liberty St.
New York, N. Y.

Short-Wave Manual

Prepared by Eminent Short-
Wave Experts

Edited by H. M. BAYER

Up-to-the-Minute Data — All
Worth-While Circuits

50c

THE COPY

FULL SIZE BLUEPRINTS
BOUND IN BOOK

As practically every one today knows, some of the finest programs are being broadcast over the short-wave bands. There are many reasons for this. Paramount among them all is the fact that that entertainment, broadcast in this band, can be received over distances which with the ordinary broadcast receiver would be impossible! Thousands of letters, which pour in an unremitting stream into our offices tell the same tale—it is a common and everyday matter to receive programs from all foreign countries, from the most distant climes. England, France, Germany, towns on the African continent, from every conceivable corner of the globe where a station is located—programs come in with surprising volume and clarity. One would think they were hearing a New York, Chicago or San Francisco station until the voice of the announcer, many thousands of miles away discloses the true location of station.

In the SHORT-WAVE MANUAL you will find complete diagrams, full size blueprints pasted into the book. These tell plainly how to construct all these short-wave circuits, which our tireless laboratory researches have shown to be most efficient.

The SHORT-WAVE MANUAL contains complete information on everything concerning Short-Wave reception. Large size book (same size as Radio News) with a beautiful colored cover. Replete with illustrations, diagrams and with FULL SIZE BLUEPRINTS. This big valuable book will show you how to receive all the foreign countries clearly and easily. Write today for your copy.

EXPERIMENTER
PUBLICATIONS, Inc.

381 Fourth Avenue New York

Mail This Coupon

EXPERIMENTER PUBLICATIONS, Inc.
381 Fourth Avenue, New York RN:JY:9

Gentlemen:

Enclosed find 50c for which please send me a copy of THE SHORT-WAVE MANUAL.

Name

Address

City..... State.....

tenna dial. If the oscillator dial reads higher than the antenna dial, turn the screw of the equalizer in a little and then readjust the oscillator dial. Continue this balancing act until the two main dials read alike. They will then read alike for most other stations, with some variation on very low or very high wave stations.

In locations where extreme selectivity is required there are three adjustments provided in the Band Isolator receiver to permit obtaining the required degree. First, the long and short antenna terminals permit the use of either half or all of the primary of the antenna coil. For normal conditions, and with any but a very small antenna, only half of the primary should be used because the use of the entire primary provides abnormally tight coupling.

The second method of increasing selectivity is by adjusting the screw on the under side of the coil carriage (for which provision was made by drilling a hole through the bottom of shield SH1 and the baseboard). With this screw taken out entirely, thus permitting the primary to slide away inside of the secondary when tuned to high wavelength stations, it is probable that the coupling will be too tight for these stations, although the automatically loosened coupling will be satisfactory for the medium and low-wave stations. In other words, this automatic coupling variation arrangement does not vary the coupling in direct proportion to the wavelength. By turning this adjustment screw to the right the degree of coupling at the maximum position becomes less but remains the same as before for the medium and low-wave stations. The best position for this screw is usually that where it holds the primary (at a dial setting of 100) only half-way inside of the secondary.

The third selectivity-increasing adjustment is made by connecting only part of the primary of the first intermediate transformer, T3, into the detector plate circuit. To use this whole primary the detector plate is connected to the lower terminal of the end terminal strip of this coil and the choke, RFC1, to the top terminal. To employ only half of the primary the choke should be connected to the middle terminal instead of the top.

The foregoing features for increasing selectivity have been included and described so that any one building this receiver can obtain adequate selectivity, regardless of how bad local interference problems may be. For normal conditions of interference these special adjustments need not all be made, of course.

LIST OF PARTS USED

- C1, C2—Hammarlund ML-17, .00035 mfd. Midline variable condensers.
C3, C4, C5, C6—Hammarlund MC-11. 50 mmfd. midget condensers.
C15, C16, C17, C7—Hammarlund type EC, equalizer condensers.
C8, C9, C10, C11—Aerovox No. 250, .5 mfd. bakelite by-pass condensers.
C12, C13, C14—Aerovox No. 1450. .00025 mfd. moulded mica condensers.
C15a, C16a, C17a—Aerovox No. 1450. .0001 mfd. moulded mica condensers.
C18—Aerovox No. 1450, .001 mfd. moulded mica condensers.
CP—Yaxley No. 669, cable connector plug and mounting with two terminal jacks.
R1—Lynch metallized grid leak, 3 megohms, with mounting.
R2, R3—Lynch metallized grid leaks, 1½ megohms. with mountings.
R4, R5—Amperites No. 1A or No. 6V-199, depending on tubes used.
R6—Amperite No. 1A.
R7, R8—Aerovox No. 985, 10 ohm wire wound resistors.
R9—Yaxley No. 510, Junior filament rheostat, 10 ohms.
R11—Electrad 5000 ohm Truvolt wire wound grid resistor.
R10—Electrad 500.000 ohm Type E. Royalty potentiometer.
RFC1, RFC2, RFC3, RFC4, RFC5—National Type 90, radio-frequency chokes.
SH1—Hammarlund Type AS-1 aluminum stage shield.
SH2, SH3, SH4—Hammarlund Type HQS-1, aluminum stage shields.
S—Yaxley No. 10, midget battery switch.
T1, T2, T3, T4, T5—Hammarlund No. VI-5, special Band Isolator coil set, consisting of five coil units, complete with mountings.
VT1, VT2, VT3, VT4, VT5—Eby tube sockets.
X1, X2, X3—Eby binding posts, engraved, Short Ant., Long Ant., Gnd.
X—Bakelite binding post strip, 1½" x 3½" x 3/16".
5 Lynch bakelite mountings for the five chokes. RFC1 to RFC5.
2 Hammarlund spring clips for top terminals of screen-grid tubes.
2 National Type VED dials equipped with No. 28 illuminators.
1 Courtland Panel Engraving Co.'s drilled and engraved Band Isolator panel. 7" x 24".
Tubes—2 Cunningham C-299 (or CX-301A) for sockets VT1 and VT2. 2 Cunningham CX-322 screen-grid for sockets VT3, VT4. 1 Cunningham CX-301A for socket VT5.
Screws, wire, solder, soldering lugs, and two 1" x ¼" tubular brass collars for mounting binding post strip, X.

Squads—Attention!

(Continued from page 13)

that early in May he asked the city council for funds with which to radio-equip eight more cars.

Chiefs of police in other population centers in Cook county, in which Chicago is located, are making plans to adopt radio as has Chicago. Through the North County Police Chiefs' Association, of which Chief Freeman is a member, plans are now under way to bring every

police car in the territory within constant communication of NDS.

Throughout the entire Chicago metropolitan area, with more than 4,500,000 inhabitants, police will soon respond to a call for assistance within a few seconds, whereas hours were required in the past. On a broadcasting band of 71 meters, messages will soon be receivable only by the police and the few radio fans

with low wave receivers. This will make for a measure of secrecy which broadcasting on the regular band does not provide; for sometimes, the police are aware, the radio order which sends police squads hurrying to a certain location is also a warning to the criminal.

It is told that when the police invaded an apartment, recently, they found the hall door open and their quarry gone. The loud speaker was doing its best as the police entered, and in the horn was this note: "Sorry I could not wait. Thanks for the tip."

On another occasion radio brought squad-cars to an address in Oak Park (Ill.), the nation's largest village, eight or ten miles west of Chicago. After the detectives surrounded the building they burst in the door, only to be welcomed by the "burglar" himself. He was a pauperhanger, waiting the return of the family before starting his work. And to make the affair all the more complicated the message which brought the detectives to the scene of the supposed robbery likewise brought a crowd of several thousand people to see how police actually capture a real, live burglar.

Radio as an aid to the police goes back a number of years, in spite of the fact that it is only a matter of months that it has been adopted to any considerable extent.

The most sensational criminal case in 1910 was the wife murder committed by Dr. Crippen in London. Crippen was an

American physician of dubious repute who had resided in England for many years. The crime was the outcome of a sordid domestic triangle.

After killing his wife and safely disposing of the body, Crippen succeeded in convincing his neighbors that she had merely returned to the United States. Nevertheless he was in terror of detection, and, but for his sudden flight, the crime might never have been discovered. And had not a marvelous new force just come into being, he would probably not have been captured.

The police learned that Crippen had disguised his mistress as a boy and had disappeared, but they could not locate them. The pair had, in fact, gone to Holland, whence, under an assumed name, they had sailed for Quebec on the *S. S. Montrose*.

The captain, observing the caresses this passenger bestowed on his supposed son, discovered the deception. The *Montrose* was equipped with the newly discovered wireless, and he communicated with Scotland Yard. While the lovers dreamed of a secure future, detectives were racing across the Atlantic to meet them at their destination.

The prisoners were returned to England, where Crippen was tried, convicted, and hanged with the speed characteristic of British justice.

Radio in its first man hunt had been triumphant!

Beginner's Amplifier-Power Supply

(Continued from page 65)

condition, the battery should be tested and finally the parts themselves should be checked over. The transformer should be tested with a battery and pair of phones, as described in the article last month, and condensers should be tested after they have been disconnected from the circuit. It is necessary to disconnect the condensers from the circuit since some of them are shunted by coils or other apparatus which would apparently show a short circuit. If, after checking over all of these points, no defects are discovered and the set still does not function properly, it is best to call in someone who is more familiar with the operation and construction of sets rather than continue further.

In testing the "B" power unit and amplifier, a slightly different procedure should be followed. The wiring should first be tested with the "C" battery and a pair of phones, after the unit has been disconnected from the line and receiver. A loud click will be heard from the power transformer windings and a subdued click will be heard from the audio and output transformer. In testing the filter condensers, a battery should be connected across each of the condensers for a few seconds. A piece of wire should then be used to short-circuit the terminals of each condenser and if it is in good condition, a spark will be noticed when the connections are first made. If no spark is noticed when the condenser is short-circuited, it is more than likely defective. If the condenser is short-circuited, a spark will be seen when the battery is

touched to the condenser terminal and it should be immediately disconnected in order to prevent the battery from being injured.

This method of testing condensers is only suitable for large condensers, such as those used in the filter circuits of B power units, etc. The small fixed and variable condensers employed in the tuned circuits of a radio set will not give a spark in this way. The voltage divider can be tested with the battery and phones in order to be sure that there is a contact between all of the taps and between the ends of the resistor. The click will be reduced to some extent when the full resistance or most of the resistance is in the circuit. (This will be noticed when the two ends of the resistor are connected to the battery and phones or when the tester is connected between the higher voltage taps and the negative end of the resistor.)

As in the case of the set itself, the first thing to suspect in case of failure, is the tubes. Both the 171 and the Raytheon tube should be taken to a dealer or service man to be thoroughly tested. Next the wiring should be checked over and finally each piece of apparatus should be tested in the manner suggested above.

These suggestions for testing and locating trouble are not given with the thought in mind that trouble will be encountered. They are merely given to help those few readers who are unfortunate enough to encounter defective apparatus or who make some mistake in building their units.

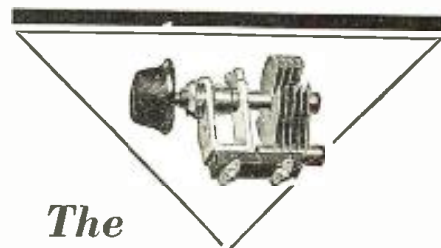

The MIDGET of Many Uses

"HAMMARLUND, JR." has all of the family characteristics—it is as carefully designed and as well made as its bigger brother the famous Hammarlund "Midline" Condenser. For neutralizing R. F. circuits; for balancing the units of a multiple condenser; for vernier tuning; for antenna selectivity—and many other places in modern receivers, here is the biggest little condenser value you can buy. Five sizes: \$1.50 to \$2.25.

Write Dept. R N 7 for descriptive folder showing diagrams of uses.

HAMMARLUND MFG. CO.
424-438 W. 33rd St., New York



ELECTRIC BATTERY 3yr. guarantee AC-8 \$40.99

Ultra 8 \$32.29

MIRACO 1 dial

30 DAYS FREE BEFORE YOU BUY

Factory to you. Save 50% on latest AC Electric or Battery Radio. Free return privilege.

Big choice of cabinets

Radio's most amazing bargains direct from big, old, reliable maker. Don't buy unless 30 days' use proves entire outfit unobtainable at 2 to 3 times the price, for tone, selectivity, distance, volume.

Free Catalog and BIG SPECIAL OFFER

MIDWEST RADIO CORPORATION
404-UJ Miraco Bldg., Cincinnati, O.

BIG DISCOUNTS to User Agents

AERO-CALL

Factory - Built, Short-Wave Converter, Filtered-Shielded. Plugs into Any Radio Set. Two Models. A.C. and D.C., \$25.00.

Write for literature

AERO PRODUCTS, Inc.
4611 E. Ravenswood Ave., Dept. 179, Chicago, Ill.

EVERYTHING IN RADIO

AT ATTRACTIVE PRICES. SETS OR PARTS.

Orders shipped exactly as ordered. Prompt Service.

Write for Prices. Inquiries invited. Send Your Address.

ALL RADIO COMPANY, 417 North Clark St., Chicago

SET BUILDERS

Get this Book

LATEST RADIO GUIDE

FREE

Barawik, the first and oldest radio specialty house, offers you unusual service this year. Bigger stocks, quicker shipments, lower prices. Deal with an old established, reliable house. Get honest goods, honest service, honest prices. Barawik service makes you more money. Send now for big new Catalog showing lowest wholesale prices.

BARAWIK CO. 27-D Canal St., CHICAGO, U. S. A.

Mail This Coupon Now for Free Radio Guide

Name _____

Address _____

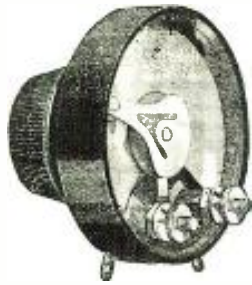

What's Behind the Knob?

Behind the knob is the volume control . . . and behind *this* volume control is the Centralab reputation and the judgment of the vast majority of radio manufacturers in choosing Centralab controls for their receivers. Centralab's exclusive rocking disc construction means adequate control for all stations and a quiet, velvety smooth action for the life of the receiver.

Centralab controls can be obtained with resistance tapers for practically every circuit.

Send for descriptive booklet, "Volume Controls and Voltage Controls . . . Their Use."

Central Radio Laboratories
20 Keefe Ave. Milwaukee, Wis.



Insure your copy reaching you each month. Subscribe to RADIO NEWS. \$2.50 per year.

Experimenter Publications, Inc.
381 Fourth Ave. New York City

The R. E. 29—Part II

(Continued from page 56)

transformers and sockets. The middle terminal of the output transformer and the two primary terminals of the input transformers are left unconnected for a while.

Mount the grid bias resistor, R4, to the left of the push-pull input transformer. Connect one side of this resistor to the center black lead on the power trans-

forming post strip and the resistor strip. Mount the condensers so that the terminal lugs are accessible with a soldering iron after the resistor and binding post strips have been mounted. Then mount these strips.

Now run a long, insulated lead from the midtap of the push-pull output transformer to the second terminal of the sec-

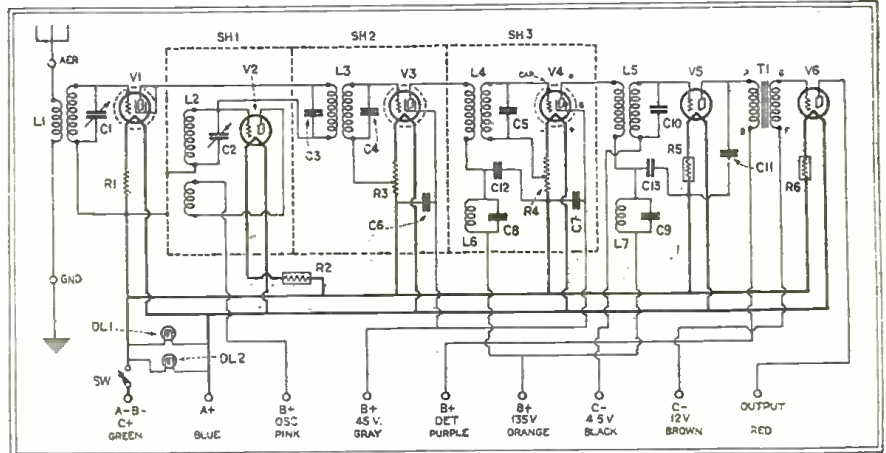

FIG. 7. THE SCHEMATIC DIAGRAM WHICH WAS PUBLISHED LAST MONTH IS SHOWN AGAIN. THE SCREEN-GRID TUBES WILL BE SEEN IN THE MODULATOR AND THE INTERMEDIATE FREQUENCY CIRCUITS

former and the other end to the midtap on the secondary of the push-pull input transformer. Mount and connect the 1 mfd. by-pass condenser, C4, across the resistor.

In the circuit diagrams of the power pack and the amplifier are some smaller by-pass condensers, not shown in the photographs. They should be mounted in front, allowing plenty of room for the

ond choke coil and to the top of the voltage divider, or to the top of the highest resistor strip. Connect all the resistors in series, following the instructions which accompany these strips.

Now connect up the binding posts to the appropriate taps on the voltage divider, and to the small by-pass condensers, if called for by the circuit diagram of the power pack and amplifier.

INDEX TO ADVERTISERS

A	E	N	T
Advance Electric Co. 93	Electrad, Inc. 78	National Co., Inc. 83	Teleplex Co. 95
Aero Products, Inc. 91	Electric Specialty Co. 81	National Radio Institute Back Cover	Townsend Labs. 88
Aerovox Wireless Corp. 80	Electric Storage Battery Co. 80	National School of Visual Education 81	Triad Mfg. Co. Inside Back Cover
All Radio Co. 91	Excello Products Corporation 80	Norden-Hauck, Inc. 82	
Allied Radio Corporation 80-89			
Arc-Aerial, Inc., The 89			
B	H	O	U
Barawik Co., The 79, 88, 89, 91, 95	Hammarlund Mfg. Co. 91	Omnigraph Mfg. Co. 81	Underground Aerial Products 79
Birnbach Radio Co. 89	Hoodwin Co., Chas. 80		
Bland, G. B. 84		P	
Braun Co., W. C. 89		Patent Electric Co., Inc. 89	
C	J	R	V
Carborundum Co., The 80	J-M-P Mfg. Co., Inc. 88	Radiall Co. 88	Van Nostrand Co., Inc., D. 87
Celeron Co., The 77		Radio 96	
Central Radio Labs. 92		Radio Equipment Co. 78	
Civil Engineering Inst. 78		Radio Institute of America 3	
Clarostat Mfg. Co., Inc. 95		Radio Training Association of America, Inc. 1	
Cornish Wire Co. 84		Rauner Radio Co. 89	
Coyne Electrical School 85			
		S	W
		See Jay Battery Co. 78	Western Radio Mfg. Co. 78, 89
		Shure Bros. Co. 82, 89	
		Silver-Marshall, Inc. 4, 5, 8	
		Southern Toy Co. 79	
D	M		X-Y-Z
Drake, The 92	Mason, Fenwick & Lawrence 82		X-L Radio Labs. 82
	Midwest Radio Corp'n. 91		Yaxley Mfg. Co. 95

Note that the P terminal on the primary of the push-pull input transformers is connected to a binding post on the strip and that the other (B) is connected to the 90-volt tap on the voltage divider, or to the corresponding binding post.

In connecting up the binding posts to the small by-pass condensers and the taps on the resistor strip it is best to use flexible, rubber-covered wire, because this is easier to handle than bus-bar wire and it is already safely insulated.

The 22- and 45-volt plus binding posts do not have any by-pass condensers. Of course, a couple may be introduced, but it is really not necessary, for these posts are adequately by-passed in the receiver.

When everything else has been finished and the circuit checked over for any possible omissions and errors, the primary leads on the power transformer should be wired to the cord which leads to the plug.

The completed power pack will give adequate plate power for the RE29 receiver or any other receiver requiring the same plate voltages and currents. The current supplied will be well filtered and free from ripple. The unit will also have a high grade push-pull power amplifier with output enough to load up any dynamic speaker.

[This concludes R. E. Lacault's article on his last receiver, the RE29, and the companion power pack. Following is information on the automatic volume control, of which Mr. Lacault left a schematic sketch, and some data on constants.—*Technical Editor.*]

In an automatic volume control for the RE-29, R. E. Lacault had in mind, just before his death, the rectification of part of the output of the push-pull stage, and the use of this rectified voltage to serve the plates of the screen-grid tubes. His laboratory notes clearly indicate what he had in mind. It was a method of automatic volume control based on the automatic variation of the plate voltage applied to the screen-grid tubes in the intermediate amplifier. The circuit diagram of this control is shown in Fig. 4. It consists of a 201A tube supplied with direct filament current from the receiver proper or from the batteries. Two long, twisted leads should be run to the set and so connected to the filament circuit that the switch therein controls the filament supply to the volume control tube. The volume control tube is connected across the loudspeaker terminals.

The tube is operated more as a detector than as an amplifier, and therefore a grid battery (E) is used for biasing. The 4 mfd. condenser is used to prevent short-circuiting the battery through the loudspeaker and the transformer winding.

A .5 megohm potentiometer is used to adjust the voltage applied to the grid of

the volume control tube. By means of this the volume level may be set at some desired value and the circuit will then maintain that level. The control tube is supplied with voltage from the 135-volt tap on the power pack. The current required by the two screen-grid tubes and the control tube flows through a resistor and a high inductance choke.

The voltage supplied to the screen-grid tubes depends on the drop in the resistance of the choke and the external resistor. The control tube is biased, so that the louder the signal the greater will be the current. Hence, the greater the signal the greater becomes the drop in the voltage and the lower the voltage applied to the screen-grid tubes.

Thus, an increase in the signal strength reduces the amplification and volume is automatically maintained at a practically constant level.

A little experimentation with the setting of the potentiometer, the value of the grid bias and the value of the external resistor is recommended.

In order that the control tube shall not act so rapidly as to level out the low-frequency signals as well as the slow fluctuations in volume, the values of 4 mfd. and 100 henrys are suggested, although larger constants may be used.

LIST OF PARTS

For Power Pack

- T1—One Amertran Type PF 250 power transformer.
- T2—One Sangamo Type B push-pull input transformer.
- T3—One Sangamo Type D-210 push-pull output transformer.
- Ch1, Ch2—Two Amertran Type 854 filter chokes.
- C1, C2, C3—Three Acme Parvolt 1,000 volt, 2 mfd. condensers.
- C4, C5, C6, C7, C8—Five Acme Parvolt 400 volt, 1 mfd. condensers.
- C9—One Acme Parvolt 400 volt, 4 mfd. condenser.
- R—One Electrad Type B 750 ohm grid bias resistor.
- One Carter resistor kit, consisting of three Type F (3,000 ohm) units, one No. 1 (7,400 ohm) tapped unit and one No. 2 (2,900 ohm) tapped unit.
- Four sockets.
- Eleven binding posts.
- One baseboard 25½ x 11¾ x ¾ inches.

(For Automatic Volume Control)

- Two 4 mfd. condensers. 400-volt test.
- One 100 henry choke coil.
- One 500,000 ohm potentiometer.
- One Lynch Equalizer No. 4.
- Four binding posts.
- One 10,000-ohm resistor.
- One small grid battery.
- One four-spring socket.

Research Expedition Uses Short Wave Radio

WHAT is considered the foremost research expedition ever conducted, and sponsored by the Philadelphia Academy of Science, the U. S. Biological Society, the U. S. National Museum, Leland Stanford, Yale, and Pittsburgh Universities, and Gifford Pinchot, will carry the latest radio equipment.

The expedition will visit the Caribbean Sea and the following islands: Galapagos,

Marquesas, Paumontos, Society, Cook, Tubnai, Gambier, Pitcairn, and Easter Islands.

The short-wave radio equipment to be used by the expedition is to be of the most modern type and consists of the famous Aero No. 52 transmitter and No. 8 International receiver, both constructed in the laboratories of Aero Products, Inc., Chicago.



To eliminate "static" from motors, street cars, telephones and electrical appliances, plug in a Falck Claroceptor between wall socket and radio set. This new improvement by a pioneer manufacturer grounds and thus blocks out line interference noise and radio frequency disturbances. Also improves selectivity and distance. Requires no changes in set. Measures just 3½x5½x2½ inches. Thousands all over America now use the Claroceptor for clearer A.C. reception. Get one right away—at radio parts dealers. Write for descriptive folder.



\$7.50
with cord and plug

Falck CLAROCEPTOR

Manufactured by ADVANCE ELECTRIC CO.
1260 W. Second Street Los Angeles, Cal.
JOBBER AND DEALERS. GET OUR PROPOSITION

BUILD THE R. E. 29!

R. E. Lacault has taken all the good features of his previous designs which were:

- L1 Ultradyne
- L2 Ultradyne
- The LR4
- The R. E. L. 9
- The Stroboddyne

and adapted them for screen grid tubes.

Full advantage has been taken of the extreme sensitivity and volume of the screen grid tubes and this added to the usual Lacault skill of designing and balancing, gives 10 kilocycle selectivity which cuts through locals and brings in distance with marvelous sensitivity and power.

One spot tuning—but the side bands are retained—thereby giving you all the low notes and all the high notes. This feature with the audio amplifier gives unsurpassed tone quality.

ALL PARTS IN STOCK FOR IMMEDIATE SHIPMENT

Estate of R. E. Lacault, Alice Lacault, Adm.
1931 Broadway, New York City

- Enclosed please find \$1.50 for which send at once blue print of the 6 tube R. E. 29.
- Enclosed please find \$1 additional for blue print of the push pull power amplifier B supply.

Please send FREE copy of the Builders' Information sheet on the complete R. E. 29.

Name

Address

City State

OPPORTUNITY AD-LETS

Follow these advertisements every month. Reliable advertisers from all over the country offer their most attractive specials in these columns.

Classified advertising rate twenty-six cents a word for each insertion. Names and addresses must be included in the above rate. Cash should accompany all classified advertisements unless placed by an accredited advertising agency. No advertisements for less than 10 words accepted.

Objectionable or misleading advertisements not accepted. Advertisements for the September issue must reach us not later than July 1st.

CIRCULATION LARGER THAN THAT OF ANY OTHER RADIO PUBLICATION

EXPERIMENTER PUBLICATIONS, INC., 381 Fourth Avenue, New York, N. Y.

Agents Wanted

Represent Factory selling guaranteed perfect-fitting Auto Seat Covers. Nationally advertised. \$100 weekly easy. Lowest prices. Largest commissions. 24-hour service. Complete Outfit Free. Supreme, 1243 Wabash, Dept. 587, Chicago.

Guaranteed Genuine Gold Leaf Letters anyone can put on store windows. Large profits, enormous demand. Free samples. Metallic Letter Co., 422 N. Clark, Chicago.

Business Opportunities

Free Book. Start little Mail Order business. Hadwil, 5A-74 Cortlandt Street, N. Y.

Amateur Cartoonists: Sell Your Cartoons. New Plan. Smith's Service EX1194, Wenatchee, Wash.

Inventions Commercialized. Patented or unpatented. Write, Adam Fisher Mfg. Co., 278 Enright, St. Louis, Mo.

Correspondence Courses

Used correspondence school courses sold on repurchase basis. Also rented and exchanged. Money-back guarantee. Catalog free. (Courses bought). Lee Mountain, Tallah, Alabama.

Detectives

Detectives Needed Everywhere. Travel. Experience unnecessary. Particulars Free. Write, American Detective System, 2190 Broadway, New York.

For Inventors

Inventions Commercialized. Patented or unpatented. Write, Adam Fisher Mfg. Co., 278 Enright, St. Louis, Mo.

Help Wanted—Instruction

Wonderful Opportunities in Government Jobs for Men-Women. 18-55; \$125-\$250 month. About 10,000 openings yearly. Are you eligible? We advise you free. Write, Instruction Bureau, 251, St. Louis, Mo.

Male Help Wanted

Firemen, Brakemen, Baggage men (white or colored). Sleeping Car, Train Porters (colored). \$150-\$250 monthly. Experience unnecessary. 237 Railway Bureau, East St. Louis, Ill.

Miscellaneous

Inventions Commercialized. Patented or unpatented. Write, Adam Fisher Mfg. Co., 278 Enright, St. Louis, Mo.

Patents

Inventions Commercialized. Patented or unpatented. Write, Adam Fisher Mfg. Co., 278 Enright, St. Louis, Mo.

Patent Attorneys

Inventors—Should write for our Guide Book, "How to Obtain a Patent," and Record of Invention Blank, sent Free. Send model or sketch of inventions for our inspection and instructions free. Radio, Electrical, Chemical, Mechanical and Trademark Experts. Terms Reasonable. Victor J. Evans & Co., 922 Ninth, Washington, D. C.

Patents—Send drawing or model of your invention for examination and instructions. Advice and booklet free. Highest references. Best results. Promptness assured. Watson E. Coleman, Patent Lawyer, 724 9th Street, N. W., Washington, D. C.

Patents—Send for form "Evidence of Conception" to be signed and witnessed. Form, fee schedule, information free. Lancaster and Alwine, Registered Patent Attorneys in United States and Canada, 289 Ouray Bldg., Washington, D. C.

Patents—Write for Free Instructions. Send Drawing or Model for Examination. Carl Miller, Registered Patent Attorney (former Patent Office Examiner), 262 McGill Building, Washington, D. C.

Printing, Engraving and Multigraphing

Multigraphing, two dollars thousand. Miscellaneous Printing. Mayer Ray Corporation, Monmouth, Illinois.

Radio

Wanted: Men to work with National Radio Service organization. No selling scheme. Radio Doctors, Inc., Dept. N., Essex St., Salem, Mass.

1929 Freed-Eiseman's—8 tube electric—List \$135.00—Special \$79.50. Orien's, King St., Holyoke, Massachusetts.

Salesmen Wanted

Amazing screw-holding screw driver! New patented invention! Removes, inserts screws instantly in inaccessible places. Sells \$1.50, 100% profit. Factories, mechanics, barbers, radio electricians buy on sight! Exclusive territory. Jifty, 1099 Winthrop Bldg., Boston.

Big Ohio Corporation wants county manager. \$50 weekly commission. Earnings start immediately. Good for \$5,000 yearly. We furnish everything, deliver and collect. Capital or experience unnecessary. Fyr-Fyter Co., 1885 Fyr-Fyter Bldg., Dayton, Ohio.

Song Poems

Song Poem Writers: "Real" Proposition. Hibbler, D7X, 2104N, Keystone, Chicago.

Song Writers

Songwriters: Substantial Advance Royalties are paid on publisher's acceptance. Write for Free Booklet on developing ideas for song words or music required by Talking Pictures. Newcomer Associate, 1674 Broadway, New York.

Stamps and Coins

Stamp Collectors—Phillips' Monthly Bulletin (illustrated) offers over 2,000 bargains, sets, packets, etc., each issue. Free. Phillips, Box 1012, Hartford, Conn.

Telegraphy

Telegraphy—Both Morse and Wireless taught thoroughly. Big salaries. Wonderful opportunities. Expenses low. chance to earn part. School established fifty years. Catalog free. Dodge's Institute, Cour St., Valparaiso, Ind.



You will enjoy luxurious comfort at THE DRAKE, food unexcelled anywhere, and this unusual added advantage: you will be out of the noise and confusion of down-town Chicago, yet within easy walking distance of its shops and theatres. Rates as low as five dollars a day single room with bath, six double. Special discounts for extended stays. Write for Illustrated Booklet, Edition 29.

Under the Blackstone management known the world over

The **DRAKE** HOTEL Chicago

(Continued from page 62)

been caused to occur at such a signal level as to just prevent serious overloading of the power a.f. stage. In practice, this acts as a sort of automatic volume regulator, for the flattening of the detector characteristic does not introduce appreciably annoying distortion, while overloading of the a.f. amplifier by the powerful r.f. section of the set proves very annoying to the listener, as tests have indicated.

The frequency response curve of the power detector at a typical signal level is shown in Fig. 4 at B. This curve is for a 30 per cent modulated r.f. signal applied to detector grid (appearing as an audio signal on the first a.f. grid). The writer believes that, because of the extreme superiority of the UY-224 tube as a power detector, it will, in the course of a short time, replace all other types of detectors in high-grade receivers. The detector obtains automatic grid bias through a 60,000 ohm resistor included in its own grid-plate return, which is bypassed by .2 mfd. in order to obtain the desired frequency characteristic, falling off at approximately 60 cycles to prevent overloading of the audio amplifier on signals of such low frequency as to contribute little to ordinary reproduction. The screen is by-passed to ground with a .1 mfd. condenser. An r.f. filter is included in the detector plate circuit, consisting of a choke coil and two .00015 mfd. by-pass condensers. A .001 mfd. condenser, together with an "Overtone Switch" to cut it in or out, is also included and will be discussed later, as will be the phonograph jack.

A response curve taken from the plate of the first audio tube to a typical load in the plate circuit of the push-pull 245-power output stage is seen in Fig. 00, at A, and leaves little to be desired.

The power supply for the receiver consists of a power transformer with necessary filament and plate windings, UX-280 rectifier tube, and a two-section filter, the first section consisting of a field of the dynamic loudspeaker, and the second section of a special high inductance a.f. choke. The power supply portion of the receiver is seen at the lower right of the schematic diagram. Approximately 220 volts can be applied to the plates of the UX-245 tubes, at which voltage the undistorted power output of the push-pull stage is approximately three watts, which is more than sufficient for home or even for small dance hall use. In order to avoid any possibility of "motor-boating" as a result of the extremely good low-frequency response of the a.f. portion of the receiver, the plate supplies for the detector, first audio, and r.f. tubes were taken from different points on the filter circuit. The wiring to permit inclusion or omission of the automatic voltage regulator by the shifting of a primary fuse is clearly indicated in the diagram. Field excitation for the dynamic speaker results from its inclusion in the power supply filter circuit.

The curves of Figs. 2, 5, and 6 are indicative of the over-all performance of the receiver. Incidentally, these curves are particularly interesting, inasmuch as they represent actual over-all measurements of a receiver of an extremely high order of sensitivity. These over-all

measurements should not be compared with measurements of individual circuit sections which, though possibly extremely "pretty" in themselves, are not indicative in any manner of over-all receiver performance.

Curve "A" of Fig. 2 indicates a sensitivity varying from 3.5 micro-volts per meter to 1.15 micro-volts per meter, throughout the broadcast wave band. This sensitivity is greater than that of any other known commercial receiver available today, and is so great as to allow practically any signal sufficiently louder than the prevailing atmospheric noise to be heard. The second curve of Fig. 4, "B," indicates a considerably more uniform level of sensitivity when the receiver is connected to a typical outdoor antenna. The sensitivity of the receiver is so great, however, that connection to an outdoor antenna is not needed, and should seldom be used except in the most favorable of isolated rural locations.

Fig. 5 shows the over-all fidelity of the receiver. To those accustomed to examining curves of audio amplifiers alone, the solid line curve of Fig. 5 appears to be only that of a very good audio amplifier. When it is considered, however, that this curve also shows the effect of all r.f. circuits in a receiver of practically unparalleled sensitivity, and of most unusual selectivity characteristics, the true excellence of the engineering design represented by this curve can be appreciated. It will prove most interesting to compare this curve to other similar curves which may be presented from time to time. At this writing it is felt that it indicates probably the greatest fidelity ever offered in any American broadcast receiver. This belief is borne out by the extreme faithfulness and brilliance of reproduction from the receiver. The reproduction is so brilliant on the higher frequencies, that to satisfy the average listener accustomed to the "drummy" reproduction provided by present-day broadcast receivers, an "Overtone Switch" which throws a condenser in the circuit to shunt out certain of the higher frequencies, is included. The fidelity curve of the set with this switch closed is seen in the dotted line curve of Fig. 5.

The selectivity of the receiver at 550 kc. is shown by the curve of Fig. 6. The band width at the top of the curve is approximately 8 kc. and the shape of the curve checks quite well with the over-all fidelity curve of Fig. 5. The steepness of the sides of the selectivity curve of Fig. 6 indicates an unusually high order of selectivity. This steepness is made possible by the combination of band selector and tuned r.f. stages (had the four tuned circuits been used to provide two band selectors, the sides would have been slightly steeper, the flat-top would have shown a slightly troughed effect, but the price paid for this negligible improvement upon the almost perfect selectivity and fidelity would have been a very great drop in sensitivity). Incidentally, it might be well to point out that when individually analyzed, the average band selector circuit will show a resonance curve slightly troughed at the peak. This effect is almost never sought, nor obtained, in a practical commercial receiver, for fairly obvious reasons.

Universal Resistance!

BY means of the adjustable micro-metric resistance obtained with the Clarostat, the radio service man can instantly obtain the precise resistance for best results in any radio circuit. Clarostat means universal resistance—hand-fitted to the requirements.

The Clarostat line includes a wide range of variable resistors, ranging from tiny Grid Leak and Volume Control types, to giant Power and Super-Power types for high-power amplifiers and auditorium installations. Also includes the Hum-Dinger—a perfected hum balancer for A-C tube circuits, and complete assortment of improved wire wound strip resistors.

There is even a refined socket antenna plug in the Clarostat line, which will generally equal a good antenna in performance—just the thing for temporary receiver installations, or as a tonic for poor reception.

In short the Clarostat line is to the radio service man what the first aid kit is to the doctor. Be prepared for all emergencies: include Clarostats in your repair kit!

Write for Literature describing the complete line of Clarostats and how the various types are applied to service problems. And if you have any special resistance problems, do not hesitate to call upon our engineering staff for cooperation.

CLAROSTAT MFG. CO., Inc.
Mem. R.M.A. Specialists in Radio Aids
281 N. 6th St.
Brooklyn, N. Y.

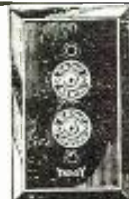

Wire Your Home for Radio

For every radio need, in brushed brass or Bakelite. Fit standard electrical switch or outlet box. Single plates and in gang in many combinations.

No. 135—For Loud Speaker.....\$1.00
No. 136—For Aerial and Ground.... 1.00
No. 137—For Battery Connections.... 2.50
No. 138—For A C Connections..... 1.00
(Bakelite, 25c additional per plate)

YAXLEY MFG. CO.
Dept. N. 9 So. Clinton Street, Chicago, Ill.

LEARN TELEGRAPHY

Be an expert Morse operator! BIG PAY—WITH TRAVEL—FUN—

ADVENTURE. After a few short weeks of practical study with Teleplex you will be an expert operator. This amazing instrument teaches you right in your own home. Works like a phonograph. No knowledge needed—beginners learn at once! NOT A SCHOOL. Free 10 days' trial. Write for FREE booklet G-11.

TELEPLEX CO., 72 Cortlandt Street, New York City



SET BUILDERS Get this Book

LATEST RADIO GUIDE FREE

Barawik, the first and oldest radio specialty house, offers you unusual service this year. Bigger stocks, quicker shipments, lower prices. Deal with an old established, reliable house. Get honest goods, honest service, honest prices. Barawik service makes you more money. Send now for big new Catalog showing lowest wholesale prices.

BARAWIK CO. 27-C Canal Sta. CHICAGO, U. S. A.

Mail This Coupon Now for Free Radio Guide

Name _____
Address _____

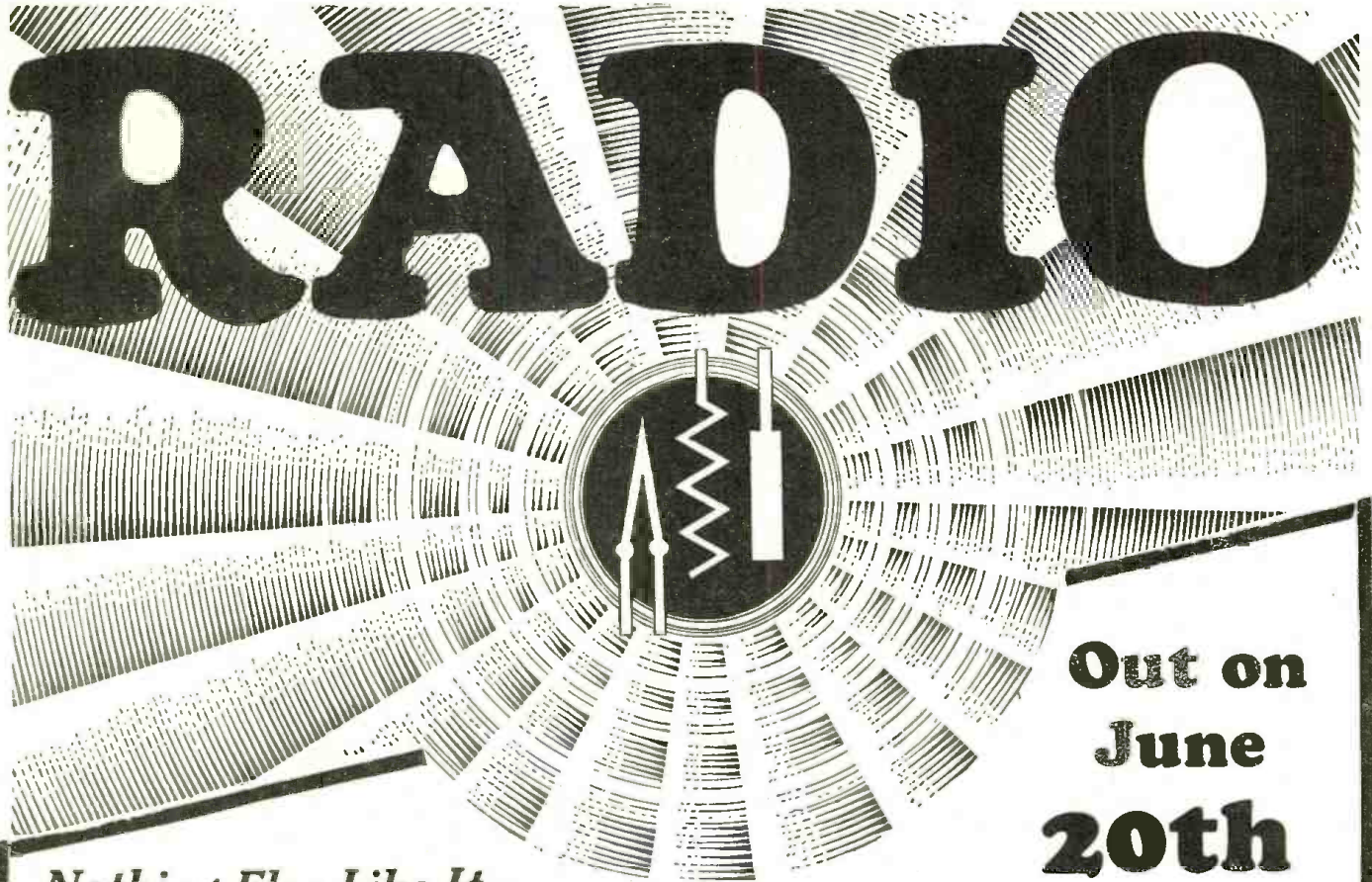

**Out on
June
20th**

Nothing Else Like It.

Circuit diagrams, specifications, prices, characteristics. Technical and non-technical data on all new 1930 radio sets, tubes, speakers, transformers, accessories and parts exhibited at the Radio Manufacturers' Show in Chicago, June 4th to 11th. Complete in every detail.

Contents:

More than 100 pages of data—ready for mailing to you only a few days after the show closes in Chicago—giving you the whole story on everything that's new in radio. Dozens of circuit diagrams on the very newest factory-built sets—shown for the first time at the show. All the new changes in radio frequency circuits, detectors and amplifiers. All the prices of all models, style numbers, specifications, etc. Data for service men and dealers. Complete tables of tube characteristics of many makes of vacuum tubes. All the new loudspeaker developments, together with prices, sizes, types and characteristics. Data on new audio systems, screen grid tubes, power tubes and rectifiers. New kits and parts for the home builder. Complete story of the show—booth by booth. Summary of the show. Forecast for 1930 radio. All this information is in the JULY issue of RADIO, out on June 20th, only a few days after the show closes. Get the JULY issue—and the five issues that follow—for only one dollar—just half the regular price. The show issue (JULY) alone sells for 50 cents per copy. The demand will be greater than the supply. **ORDER TODAY**—send a dollar bill, check or money order and the coupon. \$2.00 worth of information for one dollar—if you act now.

ALL THIS FOR ONLY

Regular Price \$2.00 **\$1.00**

Your money refunded if you are not satisfied

**Send \$1.00 and the
COUPON
[Save 50%] NOW**

Publishers of "RADIO"
428 Pacific Building
San Francisco, California

RN-7

Here is \$1.00 in full payment for a copy of the July SHOW ISSUE of "RADIO," which you will mail me on June 20th, and also send me the August, September, October, November and December, 1929, copies of "RADIO." It is fully understood that \$1.00 covers the entire cost of this subscription.

Name.....
Street and No.....
City.....
State.....

TRIAD



Type T-27



Type T-26



Type T-12-A



Type T-10



Type T-45



Type T-81



Type T-71-A



Type T-01-A



Type T-80



Type T-Tel



Type T-50



Type T-22-D.C.



Type T-24-A.C.



Type T-PEC-1

INSTANT... nation-wide popularity
...won on quality alone!

THE demand for TRIAD is sweeping along to tremendous proportions — and TRIAD quality has done it! Quality that eliminates all guesswork from tube buying and selling; quality backed by an actual bonafide guarantee of six month's perfect service or a satisfactory adjustment. Every dealer *knows* what that means — *reduced service calls, easier and quicker sales,*

greater profits and absolute satisfaction for him and his customer. Here is the greatest achievement in radio tube history — accomplished by a group of nationally-known pioneers in the industry. The TRIAD Line is complete, including even Television and Photo-Electric Cells. Don't delay — send in your stock order *now*. TRIAD customers won't accept substitutes.

Call your jobber or write us direct for complete Triad dealer information

TRIAD MANUFACTURING CO., INC.

Triad Building
 Blackstone, Middle and Fountain Sts.
 Pawtucket, R. I.

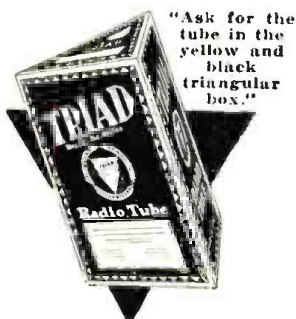

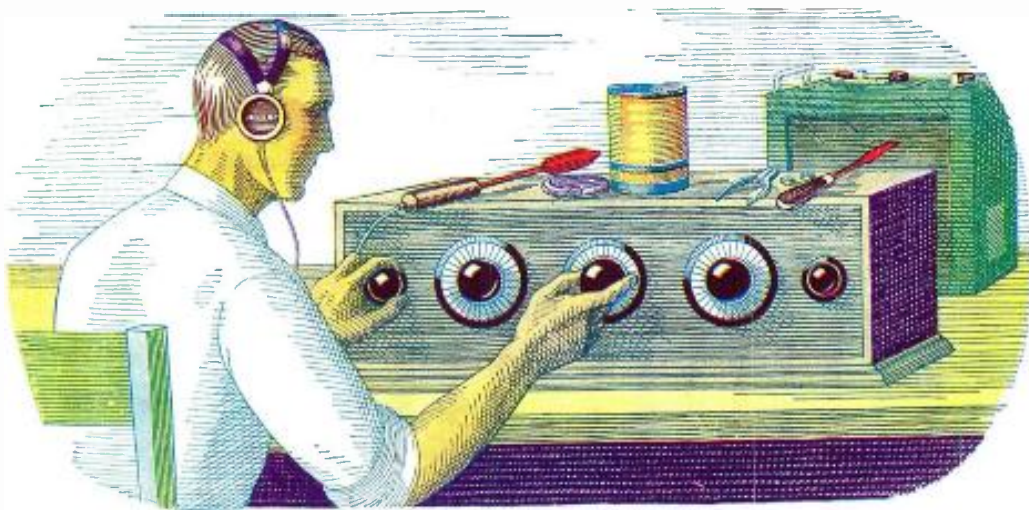

If all the Radio sets I've "fooled" with in my time were piled on top of each other they'd reach about half-way to Mars. The trouble with me was that I thought I knew so much about Radio that I really didn't know the first thing. I thought Radio was a plaything—that was all I could see in it for me.

I Thought Radio Was a Plaything But Now My Eyes Are Opened, And I'm Making Over \$100 a Week!

FIFTY DOLLARS A WEEK! Man alive, just one year ago a salary that big would have been the height of my ambition.

Twelve months ago I was skimping along on starvation wages, just barely making both ends meet. It was the same old story—a little job, a salary just as small as the job—while I myself had been dragging along in the rut so long I couldn't see over the sides.

If you'd told me a year ago that in twelve months' time I would be making \$100 and more every week in the Radio business—whew! I know I'd have thought you were crazy. But that's the sort of money I'm pulling down right now—and in the future I expect even more. Why, only today—

But I'm getting ahead of my story. I was hard up a year ago because I was kidding myself, that's all—not because I had to be. I could have been holding then the same sort of job I'm holding now, if I'd only been wise to myself. If you've fooled around with Radio, but never thought of it as a serious business, maybe you're in just the same boat I was. If so, you'll want to read how my eyes were opened for me.

WHEN broadcasting first became the rage, several years ago, I first began my dabbling with the new art of Radio. I was "nuts" about the subject, like many thousands of other fellows all over the country. And no wonder! There's a fascination—something that grabs hold of a fellow—about twirling a little knob and suddenly listening to a voice speaking a thousand miles away! Twirling it a little more and listening to the mysterious dots and dashes of steamers far at sea. Even today I get a thrill from this strange force. In those days, many times I stayed up almost the whole night trying for DX. Many times I missed supper because I couldn't be dragged away from the latest circuit I was trying out.

I never seemed to get very far with it, though. I used to read the Radio magazines and occasionally a Radio book, but I never understood the subject very clearly, and lots of things I didn't see through at all.

So, up to a year ago, I was just a dabbler—I thought Radio was a plaything. I never realized what an enormous, fast-

growing industry Radio had come to be—employing thousands and thousands of trained men. I usually stayed home in the evenings after work, because I didn't make enough money to go out very much. And generally during the evening I'd tinker a little with Radio—a set of my own or some friend's. I even made a little spare change this way, which helped a lot, but I didn't know enough to go very far with such work.

And as for the idea that a splendid Radio job might be mine, if I made a little effort to prepare for it—such an idea never entered my mind. When a friend suggested it to me one year ago, I laughed at him.

"You're kidding me," I said.
"I'm not," he replied. "Take a look at this ad."

HE pointed to a page ad in a magazine, an advertisement I'd seen many times, but just passed up without thinking, never dreaming it applied to me. This time I read the ad carefully. It told of many big opportunities for trained men to succeed in the great new Radio field. With the advertisement was a coupon offering a big free book full of information. I sent the coupon in, and in a few days received a handsome 64-page book, printed in two colors, telling all about the opportunities in the Radio field, and how a man can prepare quickly and easily at home to take advantage of these opportunities. Well, it was a revelation to me. I read the book carefully, and when I finished it I made my decision.

What's happened in the twelve months since that day, as I've already told you, seems almost like a dream to me now. For ten of those twelve months, I've had a Radio business of my own! At first, of course, I started it as a little proposition on the side, under the guidance of the National Radio Institute, the outfit that gave me my Radio training. It wasn't long before I was getting so much to do in the Radio line that I quit my measly little clerical job, and devoted my full time to my Radio business.

SINCE that time I've gone right on up, always under the watchful guidance of my friends at the National Radio Institute. They would have given me just as much help, too, if I had wanted to follow some other line of Radio besides building my own retail business—such as broadcasting,

manufacturing, experimenting, sea operating, or any one of the score of lines they prepare you for. And to think that until that day I sent for their eye-opening book, I'd been wailing "I never had a chance!"

NOW I'm making, as I told you before, over \$100 a week. And I know the future holds even more, for Radio is one of the most progressive, fastest-growing businesses in the world today. And it's work that I like—work a man can get interested in.

Here's a real tip. You may not be as bad off as I was. But, think it over—are you satisfied? Are you making enough money, at work that you like? Would you sign a contract to stay where you are now for the next ten years—making the same money? If not, you'd better be doing something about it instead of drifting.

This new Radio game is a live-wire field of golden rewards. The work, in any of the 20 different lines of Radio, is fascinating, absorbing, well paid. The National Radio Institute—oldest and largest Radio home-study school in the world—will train you inexpensively in your own home to know Radio from A to Z and to increase your earnings in the Radio field.

TAKE another tip—no matter what your plans are, no matter how much or how little you know about Radio—clip the coupon below and look their free book over. It is filled with interesting facts, figures, and photos, and the information it will give you is worth a few minutes of anybody's time. You will place yourself under no obligation—the book is free, and is gladly sent to anyone who wants to know about Radio. Just address J. E. Smith, President, National Radio Institute, Dept. 9TT, Washington, D. C.

J. E. SMITH, President
National Radio Institute
Dept 9TT, Washington, D. C.
Dear Mr. Smith:

Please send me your 64-page free book, printed in two colors, giving all information about the opportunities in Radio and how I can learn quickly and easily at home to take advantage of them. I understand this request places me under no obligation, and that no salesman will call on me.
Name.....
Address.....
Town.....State.....
Occupation.....